

Effects of temperature, particle size, and air humidity on sensibility of typical high-energetic explosives

WU Sanzhen¹, FANG Mingkun¹, WU Xingliang¹, GUO Guangfei¹, WANG Junhong¹, XU Sen^{1,2*}

1. School of Chemical Engineering, Nanjing University of Science and Technology, Nanjing 210094, China;

2. China National Quality Supervision Testing Center for Industrial Explosive Materials, Nanjing, 210094, China

*Corresponding author: XU Sen (xusen@njust.edu.cn)

Received: October 21, 2023

Revised: December 29, 2023

Accepted: January 8, 2024

Abstract: The production and utilization of high-energetic explosives often pose a range of safety hazards, with sensitivity being a key factor in evaluating these risks. To investigate how temperature, particle size, and air humidity affect the responsiveness of commonly used high-energetic explosives, a series of BAM (Bundesanstalt für Materialforschung und -prüfung) impact and friction sensitivity tests were carried out to determine the critical impact energy and critical load pressure of four representative high-energetic explosives (RDX, HMX, PETN and CL-20) under different temperatures, particle sizes, and air humidity conditions. The experimental findings facilitated an examination of temperature and particle size affecting the sensitivity of high-energetic explosives, along with an assessment of the influence of air humidity on sensitivity testing. The results clearly indicate that high-energetic explosives display a substantial decline in critical reaction energy when subjected to micrometre-sized particles and an air humidity level of 45% at a temperature of 90 °C. Furthermore, it was noted that the critical reaction energy of high-energetic explosives diminishes with an increase in temperature within 25 °C – 90 °C. In the same vein, as the particle sizes of high-energetic explosives increase, so does the critical reaction energy for micrometre-sized particles. High air humidity significantly affects the sensitivity testing of high-energetic explosives, emphasizing the importance of refraining from conducting sensitivity tests in such conditions.

Key words: high-energetic explosives; temperature; particle size; air humidity; critical reaction energy

0 Introduction

In the production and utilization of high-energy materials, sensitivity is a critical parameter that cannot be disregarded, mainly including mechanical, thermal and electrostatic stimulation. Also, in the production pipeline and transportation processes of energetic materials, collisions are inevitable, and some accidents can be attributed to mechanical impacts. Mechanical sensitivity comprises impact and friction sensitivity, which play a universal role throughout the entire lifecycle of energetic materials, from production to application. It is of great significance to study and analyze the mechanical sensitivity of energetic materials for the safety evaluation of energetic materials in production and use.

Extensive research has been carried out on the mechanical sensitivity of typical high-energetic explosives^[1,2], particularly regarding preparation processes and coating materials^[3,4]. However, there is a

notable lack of studies investigating the effects of temperature and particle size on these explosives^[5,6]. Given the inevitability of temperature variations in practical applications and production processes involving high-energetic explosives, understanding their influence is critical^[7]. The impact of air humidity on the sensitivity of high-energy explosives is significant. Some scholars have studied the effect of moisture on the sensitivity of the CL-20 eutectic system through molecular dynamics simulations^[8-10]. Additionally, due to variations in preparation processes, the sensitivity of high-energetic explosives varies with different particle sizes^[11]. In China, research on mechanical sensitivity^[12,13] primarily relies on the impact and friction sensitivity explosion probability test methods developed by the former Soviet Union (GJB772A – 1997)^[14]. While this method can qualitatively distinguish the relative sensitivity relationships among different energetic materials, it does not provide quantifiable data on the critical reaction energy required for precise sensitivity measurements.

The Chinese military standard^[15,16] suggests adopting the character drop method to determine H_{50} , which shares similarities with the internationally employed up-and-down method for sensitivity testing^[17-19]. Conversely, foreign scholars^[20,21] have utilized BAM (Bundesanstalt für Materialforschung und-prüfung) impact and friction sensitivity testers to obtain critical reaction energies for the mechanical sensitivity of various energetic materials.

In this study, four typical high-energetic explosives, RDX, HMX, PETN and CL-20, were tested for BAM impact and friction sensitivity. The main purpose was to determine the critical reaction energies of these explosive materials under different temperature and particle size conditions. The investigation aimed to explore the impact of varying temperatures, air humidity levels, and particle sizes on the sensitivity of these high-energetic explosives. Analysis of the resulting influence mode provides reliable data support for the production, storage, utilization and disposal of representative high-energetic explosives, such as RDX, HMX, PETN and CL-20.

1 Test samples and methods

1.1 Test samples

For the commonly used bulk explosives RDX, HMX, PETN and CL-20, two distinct samples were selected for testing, with each sample having different particle size parameters. Detailed information regarding the test samples is presented in Table 1.

Table 1 Test samples

Sample No.	Sample component	Particle size/ μm
1 [#]	RDX	5–50
2 [#]	RDX	30–150
3 [#]	HMX	20–50
4 [#]	HMX	80–150
5 [#]	PETN	2–30
6 [#]	PETN	50–160
7 [#]	CL-20	39–101
8 [#]	CL-20	116–356

To mitigate the potential influence of moisture content on the experiment, the samples were subjected to a pre-treatment step. Specifically, they were placed inside a 50 °C oven for 2 h. Following this pre-treatment, the samples were partitioned into two groups. One group was exposed to an air environment at 80%, while the other group was further subdivided into four subgroups. Each subgroup was placed in an independent vacuum furnace with the temperatures set at 25 °C, 50 °C, 70 °C and 90 °C, respectively and maintained for 3 h to ensure optimal thermal insulation and humidification before subsequent use.

1.2 Test devices

The impact sensitivity testing device used was the German R&P (BFH 12) BAM Drop Hammer apparatus. The drop hammer was selected with the weights of 1 kg and 2 kg. The test sample weighed (30 ± 1) mg, and the drop hammer fell freely from parallel rails on both sides. The BAM apparatus was used for the sleeve and anvil used in the test. Please refer to Fig.1 for illustration.

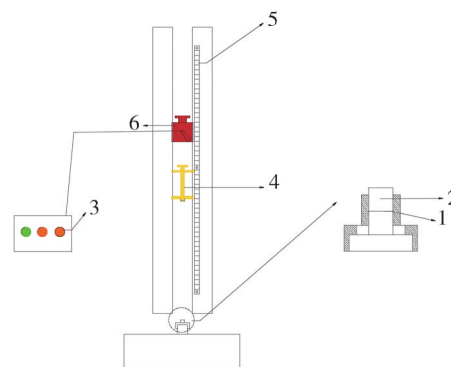

1—Test sample; 2—Impact anvil and impact sleeve; 3—Switch; 4—Drop hammer; 5—Scale and slide; 6—Electromagnets and release devices

Fig. 1 BAM impact sensitivity apparatus

The friction sensitivity testing device used was the R&P German BAM Friction Sensitivity apparatus. The test sample weighed (20 ± 1) mg. The testing device included 9 different specifications of weights and has a total of 6 testing positions, allowing the friction sensitivity apparatus to test within the range of 0 N—360 N. The BAM Friction Sensitivity apparatus is illustrated in Fig.2.

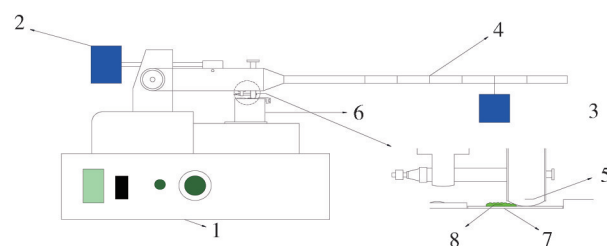

1—Switch; 2—Counterweight; 3—Weight load; 4—Lever arm; 5—Porcelain pillar; 6—Mobile platform; 7—Porcelain plate; 8—Test sample

Fig. 2 BAM friction sensitivity apparatus

1.3 Test methods

The BAM impact sensitivity tester was utilized to determine the critical impact energy (unit: J), denoted as Method 1 data, for different test samples. Additionally, the BAM impact sensitivity tester with the up-and-down method was employed to calculate E_{50} (unit: J), referred to as Method 2 data, for the various test samples. The BAM friction sensitivity tester was

used to measure the critical load pressure (unit: N) for each test sample.

During the process of the BAM impact and friction sensitivity tests, the critical reaction energy of the test samples was calculated. If an explosion or noticeable flash occurs during the test, it is documented as a “1” response. Conversely, if such an event is not observed, it is recorded as “0”, indicating no response. Each test sample underwent a maximum of six repeated trials under each test condition. In the case that any one of the six test results produces a “1”, the corresponding stimulation level is lowered, and the test is repeated until six consecutive “0” responses are obtained at a specific stimulation level. On the other hand, if all six test results are “0”, the stimulation level is increased accordingly, and the test is repeated until at least one “1” response appears in six consecutive trials at a particular stimulation level. The phenomena of the impact and friction sensitivity tests are shown in Fig.3.

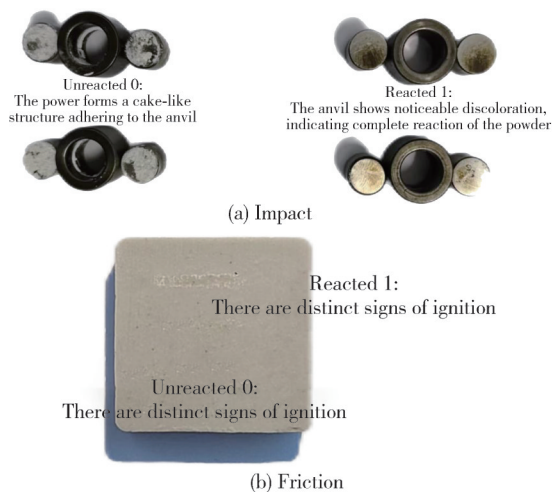

Fig. 3 Illustration of impact and friction sensitivity tests

The critical reaction energy of the sample is determined by identifying the initial stimulation level among six consecutive “0” responses where the subsequent “1” reaction occurs. The calculation for the sample’s critical impact energy is

$$E = Mgh. \quad (1)$$

where M represents the mass of the hammer (unit: kg), g denotes the acceleration due to gravity, which is assumed to be $10 \text{ m}\cdot\text{s}^{-2}$, and h represents the height of the hammer (unit: cm).

The BAM impact sensitivity tester exhibited a gradient of 0.5 J, ranging from 1 J to 50 J. Conversely, the BAM friction sensitivity tester demonstrated a variable gradient, depending on the positioning of the weights. The test procedure involved the utilization of the standardized BAM friction sensitivity tester, equipped with a friction load

pressure gauge with a range of 5 N–360 N.

2 Effect of temperature

It is essential and imperative to comprehend the impact of temperature on energetic materials, considering the temperature fluctuations encountered throughout their manufacturing and application procedures. Previous scholarly works and pertinent sources have predominantly focused on investigating the influence of temperature on energetic materials by using isolated high-temperature environments. However, the dependability of such experimental approaches is constrained. Consequently, in this study, a comprehensive examination by selecting four different temperatures, that is, 25 °C, 50 °C, 70 °C and 90 °C, was conducted to thoroughly investigate the effects of thermomechanical coupling factors on the mechanical sensitivity of energetic materials under different temperature conditions.

2.1 BAM test data and analysis

The study aimed to explore the influence of temperature by conducting experiments on heat-treated and dried samples in a controlled humidity environment with 45%. The obtained results, in Table 2, demonstrate that sample 1[#] displayed a critical impact capacity of 5 J under these specific test conditions. This result aligns with the standard value reported in Refs.[7, 12], indicating a satisfactory level of accuracy in the experimental setup. For more comprehensive findings, please refer to Tables 2 and 3 for detailed results of the conducted experiments.

Table 2 Impact sensitivity test results of samples at different temperatures

Sample No.	Test condition/°C	Impact sensitivity/J
1 [#]	25	5.0
	50	4.5
	70	4.0
	90	4.0
3 [#]	25	4.5
	50	4.0
	70	3.5
	90	3.5
5 [#]	25	3.0
	50	3.0
	70	2.0
	90	2.0
7 [#]	25	2.0
	50	2.0
	70	1.0
	90	<1.0

In the investigation of temperature’s impact on impact sensitivity, Table 2 reveals that the impact sensitivity of the four monoenergetic materials remained consistent and

stable within the temperature range of 25 °C to 50 °C. However, a significant variation in sensitivity is observed between 50 °C and 70 °C, resulting in a noticeable decrease in critical impact energy and an increase in sensitivity for the energetic materials. Between 70 °C and 90 °C, no significant changes in sensitivity are observed, except for sample 7[#], which exhibits a decrease in critical impact energy at 90 °C, falling below the lower limit of the testing apparatus (1 J). Comparative analysis among the four monoenergetic materials demonstrates that, under identical temperature conditions, the ranking of critical impact energy is as follows: 1[#] > 3[#] > 5[#] > 7[#]. Particularly noteworthy is the significantly higher sensitivity exhibited by the monoenergetic material CL-20, further emphasizing the ongoing necessity to address its sensitivity concern.

Table 3 Friction sensitivity test results of samples at different temperatures

Sample No.	Test condition/°C	Friction sensitivity/N
1 [#]	25	128
	50	128
	70	120
	90	120
3 [#]	25	108
	50	108
	70	96
	90	96
5 [#]	25	48
	50	54
	70	48
	90	42
7 [#]	25	54
	50	54
	70	48
	90	42

As shown in Table 3, the examination of the influence of temperature on friction sensitivity shows that the sensitivity of the four mono-energy materials remains relatively consistent within the temperature range of 25 °C to 50 °C. Only sample 5[#] displays a slight increase in critical load pressure at 50 °C, but this increment falls within the margin of measurement error, with 48 N and 54 N falling within the same gradient interval. A substantial variation in sensitivity is evident between 50 °C and 70 °C, characterized by a notable decline in critical load pressure and an increase in sensitivity for energetic materials. No obvious sensitivity change is observed between 70 °C and 90 °C. Based on the recommendations outlined in the United Nations Recommendations on the Transport of Dangerous Goods, substances with critical load pressures below 80 N are deemed unsuitable for transportation in their tested form. Both sample 5[#] and sample 7[#] exhibit critical friction load pressures below 80 N, indicating higher sensitivity. Therefore, there is an urgent need to promote the application of desensitization technology of these two

materials^[1].

2.2 Effect of temperature on susceptibility of typical high explosives

As depicted in Fig.4, in the temperature range of 25 °C to 90 °C, the impact sensitivity and friction sensitivity of the four samples exhibit a progressive increase with the increase in temperatures.

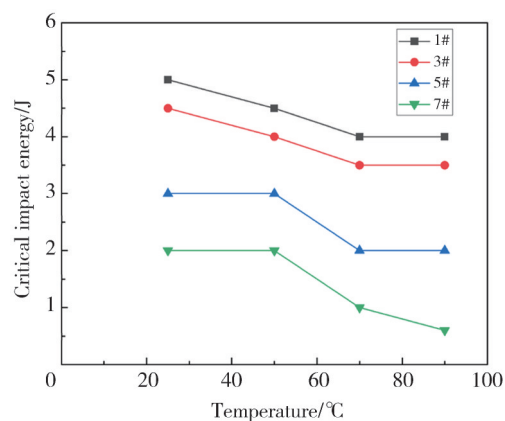

(a) Impact sensitivity

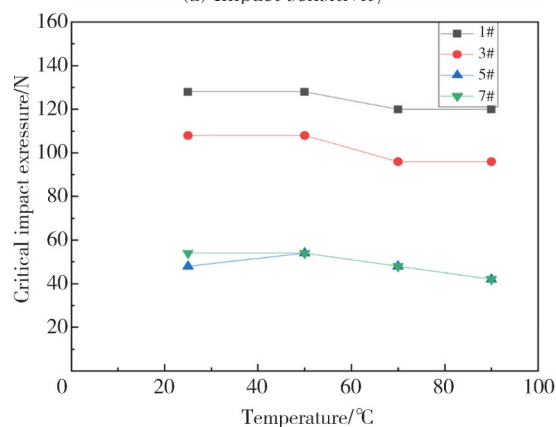

(b) Friction sensitivity

Fig. 4 Trends of sample sensitivity at different temperatures

The impact sensitivity of the four samples changes by 20%, 22.2%, 33% and 50%+, respectively. The friction sensitivity changes by 6.3%, 11.1%, 12.5% and 22.2%, respectively. Notably, RDX, HMX, and PETN display inflection points in their sensitivity curves, primarily concentrated between 50 °C and 70 °C. As the temperature continues to rise, the change of critical impact energy for the energetic materials becomes less significant. Moreover, both RDX and HMX demonstrate minimal changes in critical load pressure. In contrast, the critical impact energy and critical load pressure of CL-20 decrease continuously with the continuous temperature increase. PETN also showcases a similar behavior in critical load pressure as observed in CL-20 under rising temperatures.

The results presented in Fig.1 clearly demonstrate that

both CL-20 and PETN exhibit notably lower impact sensitivity and friction sensitivity compared to RDX and HMX. Therefore, in the process of production and application, the most important thing is to be more cautious in safety measures to reduce the potential risks related to shock and friction stimulation. Additionally, it is observed that these two highly sensitive high-energetic explosives continue to display a decreasing trend in sensitivity beyond 70 °C. The experimental findings suggest that compared with RDX and HMX, CL-20 and PETN are more susceptible to temperature changes. Furthermore, it is noteworthy that all four relative humidity representative high-energetic explosives exhibit a significant increase in sensitivity as temperatures rise. Therefore, it is strongly recommended to minimize operations at high temperatures, particularly when the temperature surpasses 70 °C.

3 Effect of particle size

In the production and application of energetic materials, variations in particle size frequently arise due to factors such as different production batches, material states, and intended applications. Understanding the influence of particle size on the sensitivity of high-energetic explosives is of utmost importance, as it directly impacts the safe handling and utilization of materials with varying particle sizes. Consequently, it is necessary and urgent to conduct a comprehensive investigation into the relationship between the particle size of energetic materials and mechanical sensitivity. Within the scope of this study, two commonly employed particle sizes were selected for each of the four representative high-energetic explosives, so that the influence of particle size on their respective mechanical sensitivity can be analyzed.

3.1 BAM test data and analysis

The heated and dried samples were used to study the particle size effects. The experiments were carried out at two different temperatures, 25 °C and 90 °C, and the humidity was 45%. Consistent with the temperature influence findings, the vulnerability to impact was noted to be 5 J and 4 J, whereas the vulnerability to friction was assessed at 128 N and 120 N for the 1[#] sample at 25 °C and 90 °C. This result aligns with the standard value reported Refs.[7, 12]. Moreover, Ref.[5] indicates that CL-20's impact sensitivity has a drop height of 1 kg, 23 cm, which is similar to the BAM test result of 3 J^[5], indicating a satisfactory level of accuracy in the experimental setup. The results of these experiments are presented in Tables 4 and 5.

Table 4 Impact sensitivity at different sample particle sizes at 25 °C and 90 °C

Sample No.	Test condition/°C	Impact sensitivity/J
1 [#]	25	5.0
	90	4.0
2 [#]	25	5.0
	90	4.5
3 [#]	25	4.5
	90	3.5
4 [#]	25	5
	90	4
5 [#]	25	3
	90	2
6 [#]	25	3.5
	90	2.5
7 [#]	25	2
	90	<1
8 [#]	25	3
	90	1

Table 5 Friction sensitivity at different sample particle sizes at 25 °C and 90 °C

Sample No.	Test condition/°C	Friction sensitivity/N
1 [#]	25	128
	90	120
2 [#]	25	144
	90	128
3 [#]	25	108
	90	96
4 [#]	25	120
	90	108
5 [#]	25	48
	90	42
6 [#]	25	54
	90	48
7 [#]	25	54
	90	42
8 [#]	25	60
	90	48

In the investigation of the influence of particle size on the impact sensitivity, Table 4 shows that the critical impact energy of RDX with two particle sizes has minimal variation at 25 °C, and remains at 5 J. However, for HMX, PETN and CL-20, the samples with larger particle sizes show an increase in critical impact energy. Specifically, HMX exhibits a change of 0.5 J, PETN shows a change of 0.5 J, and CL-20 exhibits a change of 1 J. With the increase of particle size, the impact sensitivity of the four samples changes by 0%, 11.1%, 16.6% and 50% at 25 °C, respectively, and the impact sensitivity distribution changes by 12.5%, 14.3%, 25% and 50%+ at 90 °C, respectively. The friction sensitivity changes by 12.5%, 10%, 12.5% and 11.1% at 25 °C, respectively, and the friction sensitivity distribution changes by 6.3%, 12.5%, 14.3% and 14.3% at 90 °C, respectively. In addition, the critical impact energy of all the samples increases with the increase of particle size at 90 °C.

In the investigation of the influence of particle size on

friction sensitivity, Table 5 reveals that for RDX, HMX, PETN and CL-20, the samples with larger particle sizes display higher critical load pressures than those with smaller particle sizes. Notably, among the different samples, samples 2[#], 4[#] and 6[#] show the same friction sensitivity at 90 °C as those of samples 1[#], 3[#] and 5[#] at 25 °C. Additionally, the friction sensitivity of sample 8[#] at 90 °C is slightly lower than that of sample 7[#] at 25 °C. Similar to impact sensitivity, under the test conditions of 25 °C and 90 °C, the critical load pressures of all samples increase with an increase in particle size.

3.2 Effect of particle size on susceptibility of typical high explosives

As illustrated in Fig.5 and Fig.6, it is evident that the impact sensitivity and friction sensitivity of the four selected samples decrease with an increase in particle size within the chosen micrometer-scale range. It is worth noting that in the impact sensitivity test at 25 °C, the sensitivity values for the two particle sizes of RDX samples are equal.

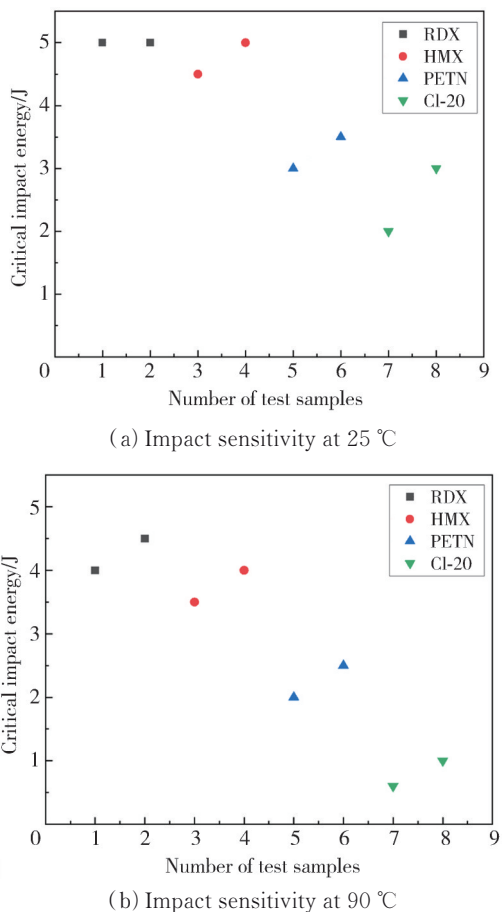

Fig. 5 Trends of sample impact sensitivity with different particle sizes

Based on the consensus in Refs.[2, 3, 4], there is a widely held belief that reducing particle size increases the critical energy of the sample, thereby making ultrafine particle size

reduction an effective approach for sensitivity reduction. However, a meticulous examination of the synthesized experimental findings reveals a contrasting result within a specific range of particle sizes, with a decrease in particle size leading to a reduction in the sample’s critical energy. Therefore, it is urgent to determine the appropriate scale for particle size reduction and identify the optimal particle size for different samples during ultrafine processing to achieve the desired sensitivity reduction. Addressing this pressing issue necessitates immediate attention and resolution.

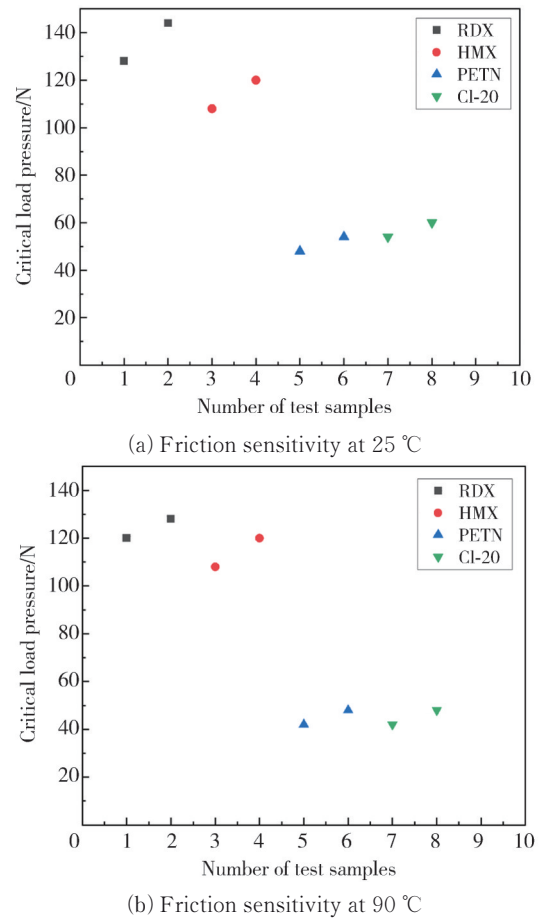

Fig. 6 Sample friction sensitivity with different particle sizes

4 Effect of air humidity

In the context of safety performance testing for energetic materials, it is not uncommon to encounter non-reproducible results and discrepancies among test outcomes obtained by different individuals. These inconsistencies can be primarily attributed to variations in subjective judgment and the influence of air humidity. Therefore, it is imperative to conduct a comprehensive investigation into the influence of air humidity during the testing process. The national military standard GJB772A — 1997 stipulates that the environmental humidity during tests should be kept below 50%. Beyond this threshold, there is a risk of distorting the

test results. Consequently, two distinct humidity levels, especially 45% and 80%, have been selected as experimental conditions to explore the potential influence of air humidity on the final test results.

4.1 BAM test data and analysis

The research on the influence of humidity included using heated and dried experimental samples for testing, and then placing them in an environment at 80%. The results of these samples were then compared with those obtained by the above tests conducted at room temperature. The experiments were conducted at 25 °C under humidity conditions of 45% and 80%. The results of these experiments can be found in Table 6 and Table 7.

Table 6 Impact sensitivity test results of samples at different humidity levels

Sample No.	Relative humidity/%	Impact sensitivity/J
1 [#]	45	5
	80	7.5
3 [#]	45	4.5
	80	6
5 [#]	45	3
	80	4
7 [#]	45	<1
	80	2

Table 7 Friction sensitivity test results of the samples at different humidity levels

Sample No.	Relative humidity/%	Friction sensitivity/N
1 [#]	45	120
	80	144
3 [#]	45	108
	80	128
5 [#]	45	48
	80	64
7 [#]	45	54
	80	72

In the investigation regarding the impact of humidity on impact sensitivity, Table 6 presents significant variations in sensitivity among different samples at various humidity levels at 25 °C. Specifically, the critical impact energy of sample 1[#] changes by 2.5 J, while sample 3[#] changes by 1.5 J, sample 5[#] exhibits a change of 1 J, and sample 7[#] demonstrates a change exceeding 1 J. At 25 °C, the impact sensitivity of the four samples changes by 50%, 33.3%, 33.3% and 50%+, respectively with the increase of air humidity. The friction sensitivity changes by 20%, 18.5%, 33.3% and 33.3%, respectively.

These results unmistakably indicate that as the humidity of the testing environment increases, the critical impact energy of the test samples also undergoes a substantial rise.

The results of this test are similar to those simulated using molecular dynamics in Ref.[10]. Similarly, in the

exploration of humidity's influence on friction sensitivity (as evidenced by Table 7), noticeable fluctuations in sensitivity are discernible for different samples at varying humidity levels at 25 °C. Notably, sample 1[#] observes a shift of 24 N in its critical load pressure, Sample 3[#] exhibits a change of 20 N, Sample 5[#] displays a variation of 16 N, and Sample 7[#] demonstrates a modification of 18 N. Consistent with the findings on impact sensitivity, all samples' critical load pressures increase as the humidity level escalates under the specified test conditions of 25 °C.

4.2 Effect of air humidity on sensitivity of typical high explosives

As depicted in Fig. 7, the critical impact sensitivity and critical load pressure of four high-energetic explosives exhibit a rapid increase with the escalation of air humidity under the selected two humidity conditions. This pronounced sensitivity impact on high-energetic explosives is evident.

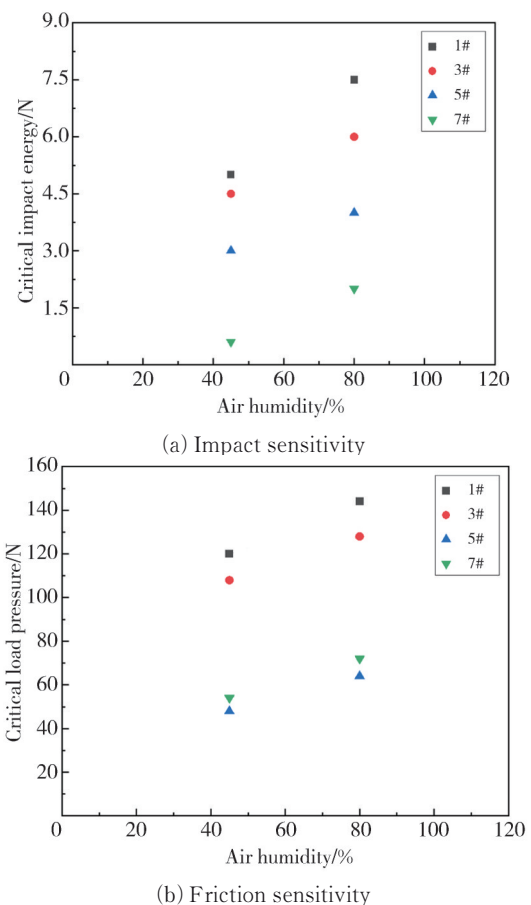

Fig. 7 Sample sensitivity under different air humidity levels

As stipulated in the GJB standards, when the air humidity exceeds a certain threshold, there will be significant differences between the measured values of impact sensitivity and friction sensitivity. Therefore, it is recommended to avoid conducting sensitivity tests for

high-energetic explosives under conditions of high humidity in order to minimize potential inaccuracies. In addition, the above test results show that the impact sensitivity and friction sensitivity of high-energetic explosives have an obvious decrease with the increase of air humidity.

Considering this, the findings from these experiments can be useful for ensuring safe storage and transportation of high-energetic explosives. By maintaining the original moisture content of the explosives and taking into account the experimental conclusions, it may accordingly be beneficial to adjust the humidity levels within the storage environment. This approach can help mitigate potential risks and ensure the safety of storage conditions.

5 Conclusions

The objective of this study was to investigate the influence of temperature, particle size and air humidity on the sensitivity of high-energetic explosives. Four types of high-energetic explosives, namely RDX, HMX, PETN and CL-20, were used in the experiments. The study design involved four temperature levels, two different particle sizes, and two air humidity conditions. Based on the experimental results, the following conclusions were drawn.

1) Temperature has a significant impact on the sensitivity of high-energetic explosives. Under the tested temperature range of 25 °C to 90 °C, as the increase of temperature, the critical impact energy and critical load pressure of high-energetic explosives are obviously reduced. Within the temperature range of 50 °C to 70 °C, there is a turning point where the sensitivity changes of RDX and HMX become less obvious. However, the high-sensitivity high-energetic explosives exhibit greater sensitivity to temperature changes, with their critical reaction energy continuously decreasing as the temperature rises.

2) Particle size also has a notable effect on the sensitivity of high-energetic explosives. Under conditions of micron-sized particles, increasing the sample particle size leads to an increase in the critical reaction energy, although the increase is relatively small.

3) Air humidity significantly affects the sensitivity of high-energetic explosives. Under the conditions of 45% and 80%, higher air humidity levels cause a significant increase in the critical reaction energy of high-energetic explosives, leading to distorted results. Therefore, it is recommended to avoid conducting sensitivity tests for

high-energetic explosives under high air humidity conditions.

These conclusions provide valuable insights for assessing and ensuring the safety of high-energetic explosives, as well as for establishing appropriate storage and usage conditions.

Acknowledgement

This work was supported by National Natural Science Foundation of China (No. 12272184).

Declaration of conflicting interests

The authors declare no conflict of interests.

References

- [1] LIANG L, CHANG Z P, ZHANG Z J, et al. Controllable batch preparation and desensitization technology of superfine CL-20. *Aerospace Shanghai (Chinese & English)*, 2020, 37 (4): 148-154.
- [2] GUO H L, HUANG Y F, JING P G, et al. Research progress on impact sensitivity of explosive. *New Chemical Materials*, 2022, 50 (5): 10-15.
- [3] HUANG X C, QIN M N, TANG W, et al. Progress of decreasing sensitivity of HMX. *New Chemical Materials*, 2014, 42 (4): 20-23.
- [4] LI G, GENG X H, WANG J Y, et al. Mechanical sensitivity of PETN with different particle sizes. *Journal of Ordnance Equipment Engineering*, 2009, 30 (6): 79-81.
- [5] WANG J L, ZHANG H B, LIU C Z, et al. Production Process to Control Particle Size of Hexanitrohexaazaisowurtzitane. *Chinese Journal of Energetic Materials*, 2021, 29 (4): 285-292.
- [6] LIU D M, XIAO J J, ZHU W, et al. MD study of PETN crystal susceptibility discrimination and mechanical property prediction at different temperatures. *Chinese Journal of Energetic Materials*, 2013, 21 (5): 563-569.
- [7] TANG Y X, GAO H X, MITCHELL L A, et al. Enhancing energetic properties and sensitivity by incorporating amino and nitramino groups into a 1, 2, 4-oxadiazole building block. *Angewandte Chemie International Edition*, 2016, 55 (3): 1147-1150.
- [8] ZHANG Y X, YANG Y, CHEN S, et al. Effect of moisture content on mechanical sensitivity and thermal decomposition of RDX. *Ordnance Industry Automation*, 2017 (7): 5-8.
- [9] YIN Y T, LI H, CAO Z H, et al. Crystallographic orientation dependence on nanoscale friction behaviour of energetic β -HMX crystal. *Friction*, 2023, 11 (12): 2264-2277.
- [10] SHA Y, ZHANG X B. Impact sensitivity and moisture adsorption on the surface of CL-20/TNT cocrystal by molecular dynamics simulation. *Applied Surface Science*, 2019, 483: 91-97.

- [11] LIU C, YE B Y, LIU Q, et al. Preparation and characterization of FOX-7 explosives with different shapes. Chinese Journal of Energetic Materials, 2022, 30(7): 659-665.
- [12] WU X L, WANG H S, LI W H, et al. Experimental study on critical response threshold of RDX and HMX under mechanical Stimulation. Explosive Materials, 2020, 49(6): 9-14.
- [13] WU Y Q, DUAN H Z, YANG K, et al. Ignition and combustion developments of granular explosive (RDX/HMX) in response to mild - impact loading. Propellants, Explosives, Pyrotechnics, 2020, 45(8): 1250-1268
- [14] WANG X J, GUO W X, LI Y N, et al. Influence of process temperatures on the coating effect and impact sensitivity of F2604/HMX composite particles. Chinese Journal of Explosives & Propellants, 2020, 43(1): 45-50.
- [15] LAI W P, WEI T, LIAN P, et al. Theoretical study on effects of particle size on impact sensitivities of nitroamines energetic compounds. Computers and Applied Chemistry, 2014, 31(7): 894-896.
- [16] LIU Y C, WANG J H, AN C W, et al. Effect of particle size of RDX on mechanical sensitivity. Chinese Journal of Explosives and Propellants, 2004, 27(2): 7-9.
- [17] YUAN J M, ZHANG Q M, LIU Y. Comparative study of explosive susceptibility test Langley method and elevation method. Chinese Journal of Energetic Materials, 2008(1): 86-89.
- [18] ROBBINS H, MONRO S. A stochastic approximation method. The annals of mathematical statistics, 1951, 22(3): 400-407.
- [19] TIAN Y B, WANG D P, FANG Y F. Comparative study of pyrotechnic firing point estimation methods. Chinese Journal of Energetic Materials, 2010, 18(1): 58-62.
- [20] ZEMAN S, JUNGOVÁ M. Sensitivity and performance of energetic materials. Propellants, Explosives, Pyrotechnics, 2016, 41(3): 426-451.
- [21] GRUHNE M S, LOMMEL M, WURZENBERGER M H H, et al. OZM ball drop impact tester (BIT-132) vs. BAM standard method—a comparative investigation. Propellants, Explosives, Pyrotechnics, 2020, 45(1): 147-153.

温度、粒度和湿度对典型高能炸药感度的影响分析

吴三震¹, 方鸣坤¹, 吴星亮¹, 过光飞¹, 王军红¹, 徐 森^{1,2*}

1. 南京理工大学 化学与化工学院, 江苏 南京 210094;
2. 国家民用爆破器材质量检验检测中心, 江苏 南京 210094

摘 要: 高能炸药在生产和使用中可能构成各种安全风险, 感度是其安全风险评估的一个重要指标。为了研究温度、粒度和空气湿度对常用高能炸药感度的影响, 采用了BAM撞击和摩擦感度仪测试了RDX、HMX、PETN和CL-20四种典型高能炸药在不同条件下的临界撞击能量和临界载荷压力。根据试验结果, 分析了温度和粒度对高能炸药感度的影响规律, 以及空气湿度对高能炸药感度测试的影响。结果显示, 在90℃、微米级粒径和45%RH空气湿度下, 高能炸药的临界反应能量明显下降, 即在25℃~90℃范围内, 随温度升高, 高能炸药的临界反应能量下降; 在微米级粒径下, 高能炸药的粒度增大导致临界反应能量增大; 高空气湿度显著影响高能炸药的感度测试, 应避免在高空气湿度下进行高能炸药的感度测试。

关键词: 高能炸药; 温度; 粒度; 空气湿度; 临界反应能量

引用格式: WU Sanzhen, FANG Mingkun, WU Xingliang, et al. Effects of temperature, particle size, and air humidity on sensibility of typical high-energetic explosives. Journal of Measurement Science and Instrumentation, 2024, 15(3): 408-416.