

Heuristic polling sequence to enhance sleep count of EPON

Bhargav Ram RAYAPATI (✉), Nakkeeran RANGASWAMY

Department of Electronics Engineering, Pondicherry University, Pondicherry 605014, India

© Higher Education Press and Springer-Verlag GmbH Germany, part of Springer Nature 2019

Abstract Next-generation passive optical networks (PONs) demand power conservation to create a green environment. A reduction in power consumption of the traditional Ethernet passive optical network (EPON) can be achieved by increasing the sleep count in optical network units (ONUs). In this paper, this is accomplished by introducing a first-in-last-out (FILO) polling sequence in the place of a fixed polling sequence to increase the number of ONUs entering sleep mode (sleep count). In a fixed polling sequence, the optical line terminal (OLT) allocates idle time to the ONUs based on the overall load of the ONUs. This leads to a situation that whenever the idle time does not meet the wakeup time threshold of sleep mode, the ONUs are put into doze/active mode, which consumes more power. In the FILO polling sequence, the first polled ONU in the current cycle is made to be polled last in the following cycle. Polling continues in this way, and by this rearrangement, the idle time of delayed poll ONUs increases; hence, it helps to reduce the power consumption. Additionally, a modified load adaptive sequence arrangement (MLASA) method is suggested, where the ONUs are categorized into doze ONUs and sleep ONUs. A numerical simulation of the FILO polling sequence with a vertical cavity surface emitting laser (VCSEL) ONU shows a maximum reduction in power consumption of 15.5 W and a 20% improvement in energy savings compared with the traditional fixed polling sequence. The MLASA method results in better power consumption with minimum delay than that of the proposed FILO and existing LASA methods.

Keywords Ethernet passive optical network (EPON), optical network unit (ONU), polling sequence, power conservation

1 Introduction

Today, the demands for green, eco-friendly, energy-efficient systems are increasing daily. In optical networks, the scope for improving energy efficiency is wider in access networks than in metro/core networks [1]. Furthermore, due to upraising services such as video on demand, internet of things, and multimedia applications, there is a need for bandwidth. A point-to-multipoint access network called a passive optical network (PON) helps in attaining more bandwidth and energy efficiency [2].

In the Asia-Pacific region, the installation of the Ethernet passive optical network (EPON), a standard of PON, has been observed [3]. The EPON, which is an Ethernet-frame-based technology, is analogous to well-established local area network technology [4]. As shown in Fig. 1, the EPON comprises major subsystems, namely, an optical line terminal (OLT) and optical network units (ONUs), which are located at the central office and the user premises, respectively. The process of communication from the OLT to the ONUs is downstream transmission, while the reverse is upstream transmission. During downstream transmission, the broadcasted signal from the OLT is received by a particular ONU based on the hardware or medium access control (MAC) address. Upstream transmission, in contrast, involves time division multiplexing (TDM), and each ONU is allocated a particular timeslot to access the OLT. Although the EPON is an energy-efficient network, further power conservation in the EPON is more probable at the ONUs. This can be made possible by switching the transmitter and (or) receiver *off* within the idle time available. The mode with the ONU transceiver *off* is known as sleep mode, whereas the mode with the transmitter alone in the *off* condition is known as doze mode [5]. Hence, the spontaneous noise effects are also compromised.

In the EPON, many methods are available to achieve power conservation and to improve energy efficiency by switching the ONUs to sleep or doze mode. Wong et al. [6] analyzed the energy efficiency by allocating static bandwidth and dynamic bandwidth to the ONUs. In

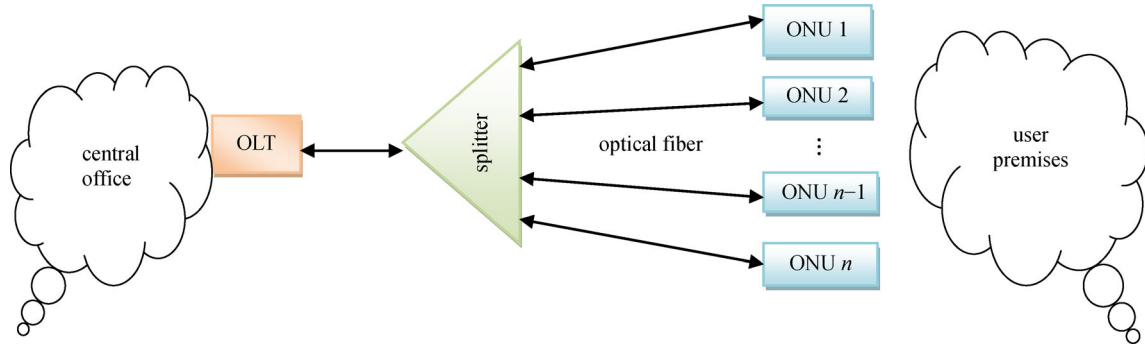

Fig. 1 Basic EPON architecture [2]

In addition, a comparison of a vertical cavity surface emitting laser (VCSEL) ONU and a distributed feedback (DFB) laser ONU was discussed. To satisfy the bandwidth requirement of ONUs by switching in between the 1G-EPON and 10G-EPON techniques, Zhang et al. [7] proposed a double sleep state and dynamic double threshold receiver selection mechanism through which the power consumption was controlled and the quality of service was achieved. Energy efficiency with asymmetric traffic was discussed in Refs. [8,9], with respect to the active, sleep and doze modes and their interstate transitions. Stating the possibility of another power saving mode, namely, transmission mode, the calculation of energy efficiency was explained in Refs. [10–12], using different possible states of the ONU. To change the common procedure of allocation of the sleep mode by the OLT, Hwang et al. [13] described decentralized service interoperability in Ethernet passive optical network (SIEPON) mechanism, which highlights the importance of energy-efficient systems by meeting the delay time of various classes of services. Butt et al. [14] reported an energy-efficient bit interleaved PON (Bi-PON) by varying the frame structure through the introduction of a decimator unit to distinguish between data sent to different ONUs. Van et al. [15] proposed an energy saving passive optical network (ESPON), where the insertion of sleep/doze mode was discussed by rescheduling the GATE, REPORT, and data transmission duration. Lv et al. [16] suggested a load adaptive sequence arrangement (LASA) method using a DFB laser ONU and the optimum sequence arrangement reference (SAR), that represents the number of delay polled ONUs resulting in sleep mode. The wireless-optical integration mechanisms were reported in Refs [17,18], where they were used to take advantage of their mobility and flexibility. Shi et al. [19] described a service level agreement (SLA)-based scheduling scheme that involves dividing the traffic at the ONU into packets according to priority and then allocating a guard time to serve high-priority packets. Garfias et al. [20] deliberated the energy-efficient dynamic bandwidth and wavelength allocation (DWBA) mechanism by switching the receivers off

according to the upstream traffic observed at the OLT. The impact of low power modes on energy efficiency was discussed by Dixit et al. [21] with various next-generation optical access (NGOA) architectures; the dependency of conservation on cycle time was also highlighted. The field programmable gate array (FPGA)-based dynamic bandwidth evaluation was discussed by Pham et al. [22], where the proposed sleep-aware dynamic bandwidth allocation (SDBA) mechanism achieves energy efficiency as well as quality of service. Dourado et al. [23] illustrated the computation of power consumption at the central office for different PON topologies for a given split ratio and bandwidth demand of the user while meeting the quality constraints.

In the literature, to the best of our knowledge, the energy efficiency of the ONU has been analyzed under the constraint of a fixed polling sequence for ONUs (no change in the TDM sequence). However, Lv et al. [16] discussed a variation in the polling sequence known as LASA with a DFB laser for ONUs, though they did not include the doze mode in the analysis. In LASA, the number of ONUs that deviate from the existing fixed polling sequence is represented by the SAR value. The optimum SAR, a sleep count reference in the LASA method, is varied to the value at which the total sleep time of the ONUs in the network is maximum. However, the power consumption can further decrease if the SAR value is varied to the extent that the idle time of delay polled ONUs satisfies the sleep mode threshold. This concept fueled the idea of the modified LASA (MLASA) method with the inclusion of the doze mode. Furthermore, the idle time of delay polled ONUs and non-delay polled ONUs are unique in the respective association. To provide different idle times to the ONUs, in this work, we propose a first-in-last-out (FILO) method, in which the scheduling sequence varies in different cycles in an FILO manner. The varied idle time to the ONUs over the fixed polling sequence results in a reduction in power consumption due to an increase in the *sleep count*. This method is applied to the VCSEL ONU and DFB laser ONU, and the modes of the ONU considered are the active, doze and sleep modes. The

performance of inter-ONU scheduling methods is also observed with respect to the following parameters: *energy savings (%)*, *maximum delay (ms)*, and *device life time*. The scheduling methods with FILO and MLASA are unique in terms of the idle times assigned to the ONUs.

The remaining part of this article is structured as follows. Section 2 discusses the existing traditional polling sequence. Section 3 deliberates the proposed polling methods for ONUs. Section 4 describes the simulation results and offers a discussion. Finally, Section 5 summarizes the paper.

2 Traditional fixed polling sequence

In the 10G-EPON, the traditional (fixed) polling sequence is used for the scheduling of ONUs. This section introduces various timing parameters, and the effect of the constant bit rate (CBR) traffic on time durations is analyzed. The OLT assigns the upstream channel to the ONUs through multi-point control protocol (MPCP) messages known as GATE (G) and REPORT (R), as represented in Fig. 2. Assuming the bandwidth requirement of ONUs is known to the OLT at the very first instance (cold start), it broadcasts a GATE message with the following attributes: data transmission duration (T_{data}), polling sequence label and idle time. Upon reception, the ONU, say ONU 1, transmits the data during the assigned T_{data} and gives the REPORT message stating the bandwidth that must still be served. Furthermore, each ONU, as shown in Fig. 2, is assigned a slot duration (T_{ONU}) for processing data with the other attributes considered. The T_{ONU} covers the data transmission duration (T_{data}), round trip time (RTT) as per the propagation distance, and control message processing time (T_{cntrl}). The T_{cntrl} is the time it takes to process the MPCP messages. After sending the REPORT message, the ONU is idle for the assigned time duration (T_{idle}), as in Eq. (1). This assignment occurs in a cyclic manner from ONU 1 to ONU n , where n represents the number of ONUs in the network, and the

next cyclic sequence restarts from ONU 1. It is also assumed that the upstream and downstream data (DATA) transmissions occur at the same time.

$$T_{idle} = T_{cycle} - T_{ONU}, \tag{1}$$

$$T_{idle} = (n - 1) \times T_{ONU}, \tag{2}$$

$$T_{idle} > T_{sleep-to-active}, \tag{3}$$

$$T_{sleep-to-active} \geq T_{idle} > T_{doze-to-active}, \tag{4}$$

$$T_{sleepONU} = T_{idle} - T_{sleep-to-active}, \tag{5}$$

$$T_{dozeONU} = T_{idle} - T_{doze-to-active}, \tag{6}$$

$$T_{cycle} = n \times \left(\frac{W_{max}}{R_u} + RTT + T_{cntrl} \right). \tag{7}$$

The timing parameters, namely, cycle time (T_{cycle}) and idle time (T_{idle}), are shown in Fig. 2. The cycle time is the time taken to process the incoming traffic from all ONUs in one TDM sequence, where the cycle time denotes the maximum cycle time duration. Furthermore, the idle time of the ONU is the time duration over which the particular ONU is not accessing the upstream channel, as given in Eq. (1) [24]. It can be modified to Eq. (2) by replacing the cycle time as the total slot duration of n ONUs. As asserted in the above section, to design the PON to be energy efficient, the ONUs not accessing the upstream channel should be granted one of the power saving modes, either sleep or doze, during their idle time durations. This scenario is possible provided the ONU idle time satisfies the wakeup time threshold of the corresponding mode. The wakeup time is the time required to recover the OLT clock and to synchronize with other ONUs. Furthermore, the ONU has to turn its transceiver on just-in-time to receive the GATE message and begins transmission after it receives the GATE message [25]. To accomplish this, it

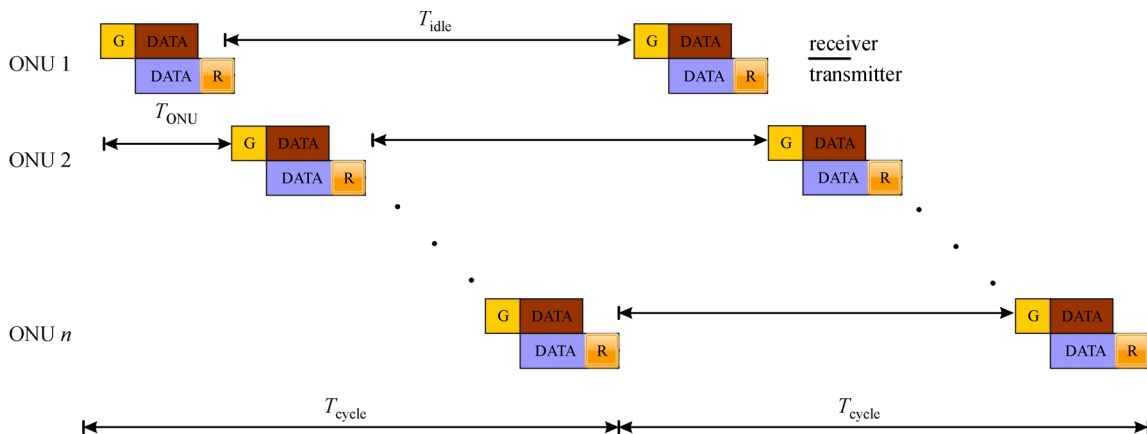

Fig. 2 Traditional fixed polling sequence [16]

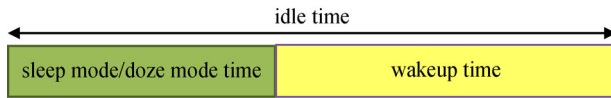

Fig. 3 Idle time partition

can be considered that the idle time duration is split into sleep/doze mode time and wakeup time, as illustrated in Fig. 3. If the idle time of the ONU is more than the sleep-to-active time ($T_{\text{sleep-to-active}}$, wakeup time), the OLT transits the ONU from active mode to sleep mode, as specified in Eq. (3); otherwise, if it is more than the doze-to-active time ($T_{\text{doze-to-active}}$, wakeup time), as given in Eq. (4), then it will be switched to doze mode [26]. The power consumption during sleep mode is lower than that during doze mode. Hence, the condition for the sleep mode is checked first. If the wakeup time threshold of both power saving modes is not met, then the ONU will stay in the current active mode. From Eqs. (5) and (6), the sleep time (T_{sleepONU}) and doze time (T_{dozeONU}) of the ONU can be calculated. The cycle time duration is represented in terms of the number of bits granted (W_{max}), upstream line rate (R_u), T_{ctrl} and RTT, as in Eq. (7).

As mentioned in the above section, at the cold start, the OLT collects the REPORT message from all ONUs and is assumed to assign the average of the requested bandwidths to each ONU. Let us consider the CBR traffic observed at each ONU. Thus, each ONU sends a REPORT message with the same bandwidth requirement in all cycles. It is also assumed that the ONUs are equidistant from the OLT, that is, 10 km apart [27]. Hence, the RTTs are equal in value. Furthermore, T_{ctrl} is assumed to be negligible. Therefore, the cumulative time duration (T_{ONU}) is identical for all ONUs. Thus, the cycle time and idle time per ONU, which are functions of T_{ONU} , are observed to be equal in value through the cycles. In this static scenario, the guard delays are assumed to be negligible, as the OLT at the central office controls the polling sequence. However, consideration of another set of CBR traffic ONUs in the network leads to different idle times. Hence, in this work, the system response for different idle times is examined.

3 Proposed polling sequence methods

In the traditional polling sequence, the idle time of the ONUs is fixed and equal in all cycles. This enables all ONUs to be in the same idle mode. To provide the ONUs with different idle times (idle modes), various polling methods are discussed in this paper by varying the TDM sequence in different cycles. The polling methods include the FILO method and the MLASA method. As mentioned in the above section, the idle time needs to be greater than the sleep mode wakeup time threshold to allow the ONUs to enter sleep mode. Thus, for the traditional polling idle

time values, which are from 0.2 to 2 ms, the ONU is switched to doze mode. Therefore, by varying the polling sequence, namely, FILO and LASA, in the proposed FILO and MLASA methods, respectively, the idle time of the delay polled ONUs for this region increases such that this rescheduling improves the *sleep count*. The slot duration and the number of bits assigned for each ONU in the FILO and MLASA methods are similar to those of the traditional method. However, the variation in the polling sequence reflects on the idle time available to the ONUs. It should be noted that the FILO method is a combination of the FILO and traditional polling sequences in their suitable ranges for the system with better power conservation. Similarly, the MLASA method is the combination of the traditional polling sequence and LASA polling sequence, with different SARs than the one considered in the LASA method.

3.1 FILO method

In the FILO method with the proposed FILO polling sequence, the inability of the traditional polling sequence is overcome by delaying the first polled ONUs in the present cycle such that it polls last in the next sequence. Similarly, the second polled ONU is made to poll last but one in the next sequence, and so on. Thus, the FILO sequence is employed for the regions in which the *sleep count* of the ONU is poorer, while in the remaining regions, the traditional polling sequence is retained. The FILO method is used with the VCSEL ONU and DFB laser ONU.

The FILO sequence is a mechanism in which the first polled ONU that is ONU 1 in the present cycle, is made to poll last in the next cycle, as presented in Fig. 4. Due to the rearrangement of the polling sequence, the idle time value of the ONUs increases/decreases compared with the traditional idle time. Thus, the ONUs whose idle time is increased may cause an improvement in the *sleep count*. As stated in Section 2, it is also assumed that the guard delay is negligible. Thus, the ONUs, which are polled last and last but one in the current cycle, are swapped in their sequence from the conventional FILO pattern for the next cycle. Otherwise, the idle time available for the last ONU would be zero. Each ONU in the polling sequence is assigned a unique label to demarcate the sequence, and it is communicated through a GATE message. On the other hand, the label in the REPORT message is useful to endorse the polling sequence.

The idle time of the i th ONU, due to the proposed FILO sequence, is represented by $T_{\text{idle-}i}$, and the idle time of the traditional polling sequence is represented by T_{idle} . During the traditional idle time (T_{idle}) that results in a doze mode that is from 0.2 to 2 ms, the provision to adopt the FILO sequence is verified. Therefore, the idle time value of the FILO polling sequence must be related to the traditional idle time, as given in Eq. (8). Here, the idle time of the i th ONU in the FILO sequence is calculated based on a value

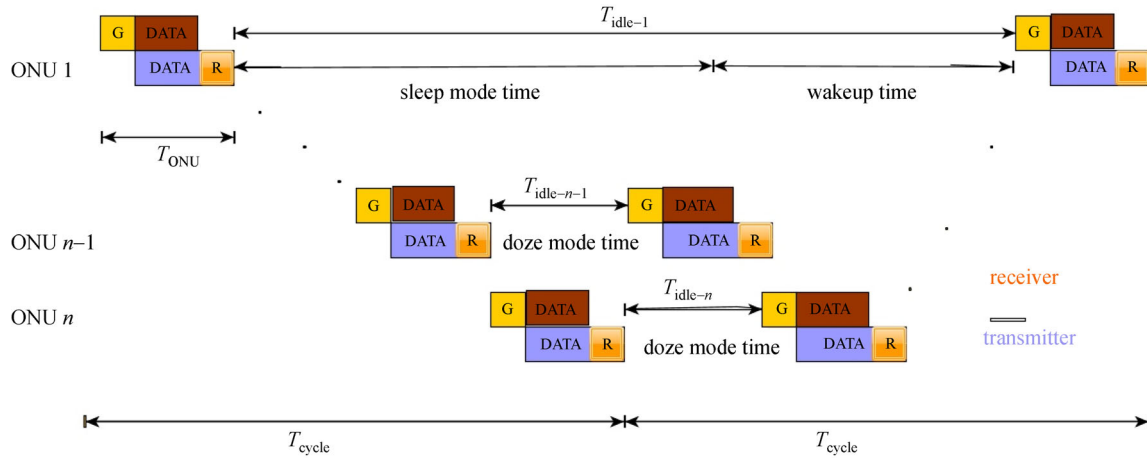

Fig. 4 FILO polling sequence with n ONUs

proportionate to the number of ONUs that are accessing the upstream channel.

$$T_{\text{idle-}i} = \frac{2 \times (n-i)}{n-1} \times T_{\text{idle}}, \quad (8)$$

$$T_{\text{idle}} > 1 \text{ ms}. \quad (9)$$

The region for the FILO sequence is chosen such that the longer idle time ($T_{\text{idle-}1}$) resulting from varying the polling sequence needs to be greater than the wakeup time of the sleep mode. Thus, the idle time of ONU 1 is also represented in terms of the sleep mode time and wakeup time, as shown in Fig. 4. By substituting the i value with 1 in Eq. (8), the lower limit of the traditional idle time for the application of the FILO sequence is identified as in Eq. (9). Therefore, during the region of idle time greater than 1 ms and up to 2 ms, the FILO sequence is considered. The ONUs that are swapped in their sequence, as mentioned above, have an idle time that is equal to T_{ONU} . This idle time is equivalent to the doze mode time since the wakeup time is negligible. The performance of the FILO method is evaluated by considering the traditional idle time as a reference. Among the variations of traditional idle time, the suitable range for the FILO polling sequence is identified, followed in the cycles. On the other hand, the fixed polling method is the polling method. The OLT at the central office controls the polling sequence as well as the swapping mechanism in the case of FILO.

3.2 MLASA method

The FILO sequence provides unique idle times to all ONUs and provides the scope for the sleep mode to a specific set of ONUs by virtue of its nature. On the other hand, the existing LASA method with the LASA polling sequence assigns equal idle time to delay polled ONUs, and sleep mode is achieved by different sets of ONUs over

several cycles. However, this method considers only the active and sleep modes and works with DFB laser ONUs. Therefore, the ONUs that do not meet the threshold for sleep mode are allowed to switch to active mode, and thus, the power consumption in the LASA method is greater than that of the FILO method. Furthermore, the FILO method is simulated with DFB laser and VCSEL ONUs.

As stated in the introduction of Section 3, the LASA, FILO and MLASA are considered in the range of values where the traditional fixed polling sequence fails to meet the required threshold for sleep mode. Hence, in that identified range, the LASA polling sequence is executed by delay polling the first polled θ ONUs in the present cycle in the next cycle [16], where θ represents the sequence arrangement reference (SAR). The optimum SAR value considered in the LASA method is computed by varying the number of delay polled ONUs until the total sleep time of the ONUs in the network is maximum [16], as in Eq. (10). The equation can be modified in terms of slot duration (T_{ONU}) and the sleep mode wakeup time (T_{wakeup}), which is 2 ms, as given in Eq. (11). Equation (11) is further modified to Eq. (12) using Eq. (2) to understand the traditional idle time (T_{idle}) reflections on the LASA method, as discussed in this paper. The computed approximated optimum value is limited by the fact that the maximum total sleep time did not include all the SAR possibilities that also result in sleep mode for the delay polled ONUs. Furthermore, it also results in the same maximum total sleep time. Rather than limiting to the maximum sleep time to achieve a further reduction in power consumption, the MLASA method is suggested by including the maximum possible *sleep count* (maximum possible SAR).

The MLASA method consists of the LASA polling sequence and the power saving modes, namely, doze mode and sleep mode. In the LASA polling sequence, it is observed that the idle time of the delayed poll ONUs

decreased as the number of delayed poll ONUs increased. From the aforementioned remarks, if the idle time of the ONU is greater than 2 ms, then it can switch to sleep mode. It should also be noted that the idle time of the delayed poll ONUs is the same. The condition for the idle time of the delayed poll ONUs ($T_{LASAmax}$) for the LASA polling sequence, which is represented in Ref. [16], in terms of the traditional idle time (T_{idle}) and the SAR (θ), is given in Eq. (13). With the variation in θ , it is evident from the conditions and observations that the maximum possible SAR (θ) for the MLASA method is the maximum value at which $T_{LASAmax}$ satisfies the 2 ms limit as in Eq. (14). The modified condition of Eq. (14) using Eqs. (1) and (2) is given in Eq. (15). As stated in the above section, the performances of the LASA and MLASA methods are evaluated by taking the traditional idle time on the x -axis. Among those values, the suitable idle time range for both methods is above 1 ms and up to 2 ms, and for the remaining idle time duration, the traditional polling sequence is followed. Moreover, both methods are considered with the DFB laser ONU only. However, the major difference between the methods is the consideration of the idle modes and the selection of θ values.

$$\theta = \frac{T_{cycle} - T_{wakeup} + (n-1) \times T_{ONU}}{2 \times T_{ONU}}, \quad (10)$$

$$\theta = \frac{(n \times T_{ONU}) - 2 + (n-1) \times T_{ONU}}{2T_{ONU}}, \quad (11)$$

$$\theta = \frac{(2n-1) \times T_{idle} - 2 \times (n-1)}{2 \times T_{idle}}, \quad (12)$$

$$T_{LASAmax} = T_{cycle} + T_{idle} - \theta \times T_{ONU}, \quad (13)$$

$$T_{LASAmax} > 2 \text{ ms}, \quad (14)$$

$$\frac{(2 \times n - 1) \times T_{idle} - (2(n-1))}{T_{idle}} > \theta. \quad (15)$$

3.3 Algorithm

The algorithm specifies the general representation of all the scheduling algorithms. This step-by-step algorithm enables understanding the considered timing values, the performance parameters and the polling sequences for this unified framework. Moreover, the response of the network parameters with the variation in idle time is discussed. The idle time variation is, in turn, the resultant of different CBR traffic sets considered at the ONU. An idle time range assumed from 1 to 3 ms for the case of the traditional polling sequence (T_{idle}) is considered in this paper. Furthermore, for the identified traditional idle time, which is from 1 to 2 ms, and with the provision of the

FILO polling sequence, the LASA polling sequence is verified. In the identified range, the variation in idle time of the ONU due to different polling methods, namely, FILO and MLASA, is computed accordingly. The idle time duration of the algorithms considered comply with the delay constraint of the service. The idle time considered, of course, attributes the delay of the system. However, as per the proposed FILO polling sequence, the system will undergo FILO polling sequences above 1 ms and up to 2 ms. On the other hand, the system will undergo a fixed polling sequence out of these idle time value ranges. Thus, at any point in time, the system will undergo FILO/LASA or a fixed polling sequence. The 4 ms delay constraint shown in Table 1 is defined as the idle time range considered in this work. After the calculation of the idle time, the mode and mode duration of the ONU are determined using Eqs. (3), (4) and Eqs. (5), (6), respectively. If the idle time of an ONU is greater than 2 ms, then the state of the ONU will be switched to sleep mode; if it is greater than 330 ns, it will be switched to doze mode and active mode otherwise. The time duration over which the ONU stays in sleep mode ($T_{sleepONU}$) or doze mode ($T_{dozeONU}$) is calculated using Eqs. (5) and (6), respectively. The idle time/cycle time range considered in this paper is limited because the primary objective is to observe the response with LASA/FILO polling sequences.

$$P_c = AC_{count} \times P_{act} + DZ_{count} \times P_{doze} + SL_{count} \times P_{sleep}, \quad (16)$$

$$\eta = \left(1 - \frac{P_{act} \times T_{act} + P_{doze} \times T_{doze} + P_{sleep} \times T_{sleep}}{P_{act} \times (T_{act} + T_{doze} + T_{sleep})} \right) \times 100\%, \quad (17)$$

$$\eta = \left(\frac{(P_{act} - P_{doze}) \times T_{doze} + (P_{act} - P_{sleep}) \times T_{sleep}}{P_{act} \times (T_{act} + T_{doze} + T_{sleep})} \right) \times 100\%. \quad (18)$$

The performance metrics, namely, the *power cumulative* (P_c) and percentage of *energy savings* (η), within the idle times between cycle, are computed using Eqs. (16) and (17), respectively. Equation (17) is rearranged to yield Eq. (18). It should be noted that the idle time of the ONUs varies for different polling methods; however, the slot durations of the ONUs in each method are equal. Hence, the mode of the ONU in respective idle time is identified. Therefore, the total number of ONUs in the doze, sleep and active modes is denoted as DZ_{count} (*doze count*), SL_{count} (*sleep count*), and AC_{count} (*active count*), respectively. The overall time duration in which the ONUs stay in power saving mode is represented by T_{doze} and T_{sleep} . Similarly, the active time (T_{act}) is a total wakeup duration and is the

time duration either from doze to active mode or from sleep to active mode. However, the slot duration, where the ONU is in active mode (i.e., the duration of mutual communication between the ONU and the OLT as well as the RTT and the control message processing time) is denoted by T_{ONU} . This scenario is explained through the stepwise algorithm given below. P_{act} , P_{sleep} , and P_{doze} represent the active, sleep and doze power, respectively. In general, for the TDM sequence, one ONU will be in active mode, while the other ONUs will be in either sleep/doze or active mode.

Stepwise algorithm:

1. In each cycle, the REPORT Messages in CBR traffic are sent from the ONU to the OLT.
2. For the chosen MLASA FILO or fixed polling methods, compute T_{idle} and T_{cycle} of the ONUs based on the average bandwidth.
3. The variations in the CBRs lead to variation in the idle time of ONUs with constant cycle time/variation.
4. for $T_{\text{idle}} = 1 \text{ ms}:0.2 \text{ ms}:3 \text{ ms}$
5. if ($T_{\text{idle}} > 2 \text{ ms}$)
6. $T_{\text{sleepONU}} = T_{\text{idle}} - 2$, $SL_{\text{count}} = SL_{\text{count}} + 1$;
7. else ($T_{\text{idle}} > 330 \text{ ns}$)
8. $T_{\text{dozeONU}} = T_{\text{idle}} - 330$, $DZ_{\text{count}} = DZ_{\text{count}} + 1$;
9. end.
10. $T_{\text{sleep}} =$ total sleep time of ONUs, $T_{\text{doze}} =$ total doze time of ONUs, $T_{\text{act}} =$ total wakeup time of ONUs, including sleep to active time and doze to active time.
11. Compute network (power cumulative, energy savings, and maximum delay).

4 Results and discussion

The algorithms of the proposed FILO method and the MLASA method are simulated using MATLAB software to evaluate their performance metrics. The parameters considered for analysis are given in Table 1. The traffic considered for the simulation is CBR traffic. In this work, the types of ONUs considered are VCSEL and DFB laser ONUs due to their advantages, including wavelength selectability, tunability, sensitivity to temperature variations and commercial availability [6,28]. From the aforementioned remarks for the idle time range from 0.2 to 1 ms, the fixed polling mechanism can be availed. However, the consideration of a distance of 10 km limits the plot from 1 ms.

As the idle times of the FILO and MLASA methods are computed in terms of the traditional fixed polling idle time, the x-axis caption of all figures is the traditional fixed polling idle time. The *power cumulative* comparison of various polling methods is illustrated in Fig. 5. The percentage of *energy savings* of the various polling methods for various values of the idle time is shown in Fig. 6. When the idle time of a VCSEL ONU lies from 1 to 2 ms, the observed *power cumulative* with traditional polling is constant at 38.5 W, where all 10 ONUs are in doze mode. However, for *energy savings*, as per Eq. (17),

Table 1 Parameters considered for analysis [6]

S. No.	parameter	value
1	number of ONUs	10
2	upstream line rate (R_u)	10 Gbps
3	delay constraint	4 ms
4	VCSEL P_{active}	3.985 W
5	VCSEL P_{sleep}	0.75 W
6	VCSEL P_{doze}	3.85 W
7	VCSEL sleep to active time	2 ms
8	VCSEL doze to active time	330 ns
9	DFB laser P_{active}	5.052 W
10	DFB laser P_{sleep}	0.75 W
11	DFB laser P_{doze}	3.85 W
12	DFB laser sleep to active time	2 ms
13	DFB laser doze to active time	760 ns
14	distance reach	10 km
15	idle time variations	1 ms:0.2 ms:3 ms

the total sleep time (T_{sleep}) is zero (i.e., due to all ONUs being in the doze mode), and the active time (T_{act}) (i.e., the total doze to active wakeup duration) variation is trivial. Thus, the variation in the idle time reflects only a shift in the doze time (T_{doze}) in the case of traditional polling, which results in *energy savings* that are constant at 3.385%. Similarly, the *energy savings* for the DFB laser ONU would be constant at 23.7%. Table 1 shows that the active mode power consumption (P_{active}) in the case of the DFB laser is greater than that of the VCSEL ONU. Hence, the selection of doze mode power savings during the idle time duration resulted in more *energy savings* in the case of the DFB laser ONU.

For idle times greater than 2 ms, all the ONUs are in sleep mode. Hence, the *power cumulative* is constant at 7.5 W, as per Eq. (16). This sleep and doze mode power consumption holds irrespective of the ONUs (i.e., either DFB or VCSEL), as stated in Table 1. Thus, the *power cumulative* trends for the DFB laser and VCSEL ONUs are similar, although the doze mode wakeup time is different for both types, and the variation in the value is trivial. On the other hand, for *energy savings*, with both types of ONUs, the doze time (T_{doze}) is zero (i.e., due to all ONUs being in sleep mode). However, the active time (T_{act}) (i.e., the total sleep to active time duration of the sleep mode ONUs) is constant throughout the region. Thus, the variation in the idle time reflects only on the shift in the sleep time, which results in an abrupt increase in the *energy savings* according to Eq. (17).

To improve the power conservation during the idle time of the traditional method that results in doze mode, a new polling sequence called FILO polling, as described earlier, is introduced to vary the idle time of the ONUs to increase the *sleep count*. This is possible if and only if Eq. (9) is

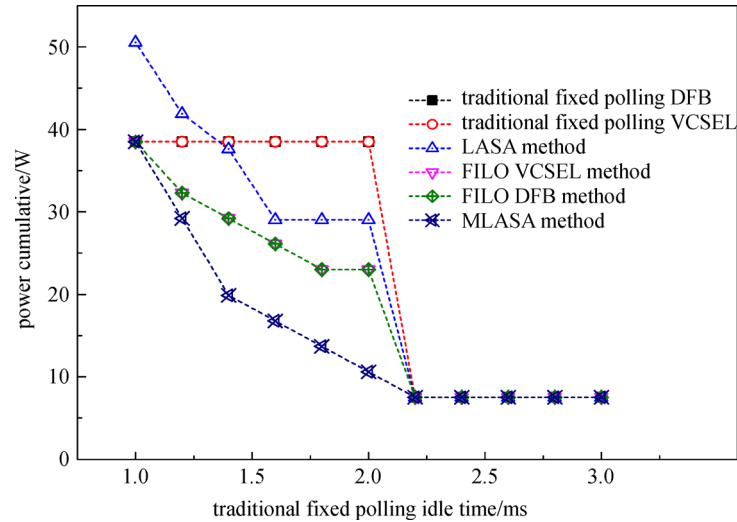

Fig. 5 Power cumulative of polling methods against idle time

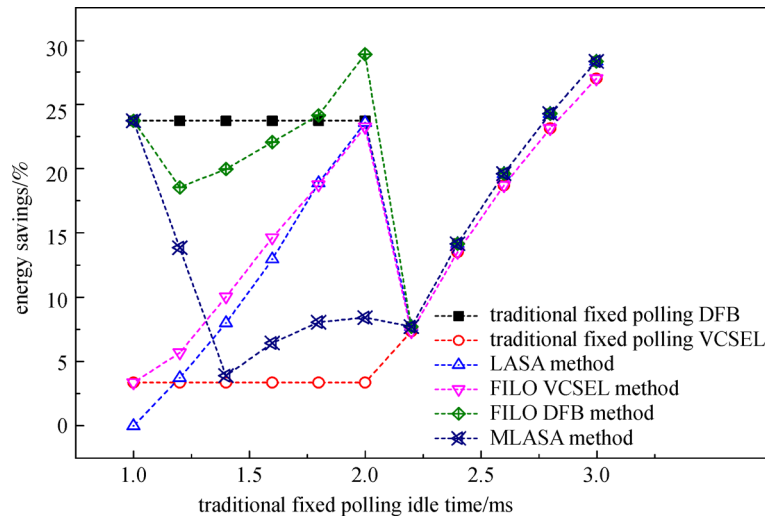

Fig. 6 Energy savings of polling methods against idle time

met, which necessitates that the idle time range must be above 1 ms and up to 2 ms. However, outside this idle time range, that is, from 0.2 to 1 ms and greater than 2 ms, the ONU follows the traditional polling method.

During the FILO range, for a variation in idle time from 1 to 2 ms, the sleep count is increased. Due to this increase, there is a reduction in the *power cumulative*, as per Eq. (16). Therefore, at an idle time of 2 ms, as per the traditional polling method, all 10 ONUs would be in doze mode. On the other hand, in the case of the FILO polling method, 5 ONUs alone would be in doze mode, while the remaining 5 ONUs, in sleep mode. The fifty percent reduction in the *doze count* or increase in the *sleep count* resulted in an approximately 15.5 W reduction in *power cumulative* in the PON network. For the *energy savings*, in both ONU types, the increase in the number of sleep mode ONUs resulted in an increase in the sleep time (T_{sleep}) and

active time (T_{act}) and a decrease in the doze time (T_{doze}). The substitution of the corresponding timing values in Eq. (18) disclosed the increased *energy savings* behavior with respect to the variation in idle time, as shown in Fig. 6. Thus, at an idle time of 2 ms, the adoption of the FILO polling sequence instead of the traditional method resulted in a 20% improvement in the *energy savings* with the VCSEL ONU.

The comparison of the *power cumulative* (P_c) and the percentage of *energy savings* (η) for the idle times 2, 1.6 and 1 ms of different polling methods is described in Table 2. In the LASA method, the ONUs stay in active mode for the idle time range less than or equal to 1 ms. On the other hand, at 1 ms, due to the FILO method, the ONUs are in doze mode, thus resulting in 12 W reductions in the *power cumulative* when compared to the LASA method, as shown in Table 2. Similarly, there is an improvement of

Table 2 Performance comparison of different polling methods

method	idle time = 2 ms		idle time = 1.6 ms		idle time = 1 ms	
	P_c/W	η /%	P_c/W	η /%	P_c/W	η /%
traditional fixed polling DFB	38.5	23.7	38.5	23.7	38.5	23.7
traditional fixed polling VCSEL	38.5	3.38	38.5	3.38	38.5	3.3
LASA method	29.0	23.6	29.0	12.9	50.5	0
FILO VCSEL method	23.0	23.3	26.0	14.6	38.5	3.3
FILO DFB method	23.0	28.9	26.0	22.1	38.5	23.7
MLASA method	10.6	8.4	16.8	6.4	38.5	23.7

23.7% in the *energy savings* due to the FILO DFB method compared to that of the LASA method.

The *sleep count* (number of sleep mode ONUs) with respect to the variation in the traditional idle time (T_{idle}) for the LASA method and MLASA method (that are calculated as per Eqs. (12) and (15), respectively) is shown in Fig. 7. During the idle time range considered (from 1 to 2 ms), the *sleep count* due to the MLASA method is observed to be greater than that due to the LASA method. The 50% to 100% increase in the *sleep count* resulted in a 30.1% to 63.46% decrease in the *power cumulative*. However, the ONUs other than those in sleep mode are in doze mode and active mode for the MLASA method and LASA method, respectively. The substitution of the corresponding mode counts results in a better *power cumulative* (as per Eq. (16)) for the MLASA method compared to that for the LASA method, as shown in Fig. 5. The adoption of the doze power saving mode and variation in mode timing results in better *energy savings* with the MLASA method at an idle time of 1 ms than that with the LASA method, as shown in Fig. 6.

The *maximum delay* experienced (i.e., the ONU having maximum idle time) by various methods is plotted in Fig. 8. In this system, other delays are considered to be

negligible; therefore, the delay is directly proportional to the idle time. The increase in the SAR (*sleep count*) for the MLASA method results in a decrease in the idle time compared with the LASA method. It is also observed that the FILO sequence has *maximum delay* among the methods [29]. On the other hand, the *device life time* is the metric that represents the reparations and cost aspects. The average *off* (T_{off} , idle time) and *on* (T_{on} , slot time) durations of ONUs, as in Eq. (19), are equal in all polling sequences. The failure rate (γ) when the device is in the active state (γ_{on}) or in the sleep state (γ_{off}) is assumed to be the same in both sequences. The last division term denotes how frequently the operational state changes. The state transitions in the LASA method, as explained in Ref. [16], are less than those in the FILO method. Therefore, the *device life time* ($1/\gamma$) is less in the FILO method than in the LASA method.

$$\gamma = \frac{T_{on}}{T_{total}} \gamma_{on} + \frac{T_{off}}{T_{total}} \gamma_{off} + \frac{f_r}{N_f \times T_{total}}. \quad (19)$$

In this work, the considered CBR traffic, with an average bandwidth of the REPORT messages and equidistant ONUs, resulted in equal cycle times and the same idle time per ONU. However, the variable bit rate (VBR) traffic

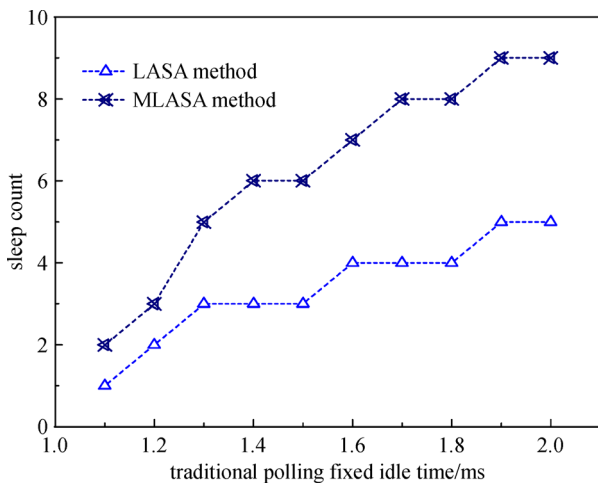

Fig. 7 Performance evolution of the LASA method and MLASA method

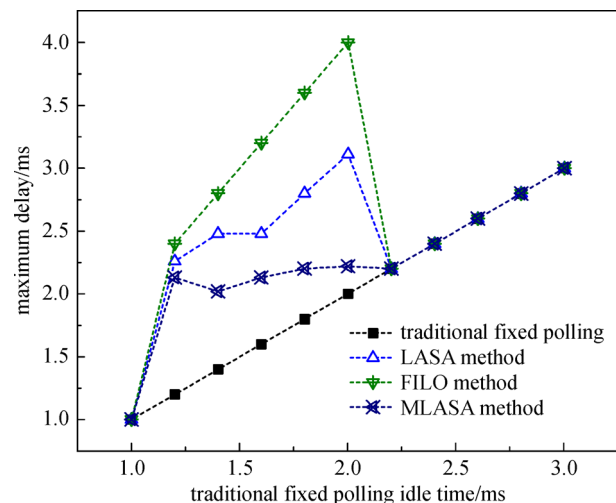

Fig. 8 Delay exploration against idle time

results in different cycle times and different idle times per ONU. Incidentally, to match the real-time scenario, in our previous work [30], the applicable region of LASA is identified with VBR traffic by considering two different cycle times (resultant of fixed polling sequence), with each cycle time being proportional to the other. As the proportionality increases, the applicable range of LASA was observed to be delayed or extended with equal ranges of values considered for the maximum and minimum idle times, respectively. The considered average value of the REPORT messages resulted in equal transmission durations per cycle. In that work, the distance reach is not considered. Furthermore, the power consumption (cumulative), depending on the state of the ONU with maximum/minimum traditional idle time variations, was measured and compared with the fixed polling sequence. An empirical model was established to identify the counts, considering every possible parameter variation. However, that analysis is carried out by considering part of the system with due possible limitations. The possible approaches for the fully elaborated system can be addressed provided the cycle times over the cycles are predicted in advance. That prediction mechanism may possibly be attempted by observing the usage patterns of users with the help of machine learning algorithms, as discussed by Frigui and Lemlouma [31]. On the other hand, the methodology with fixed cycle time is expounded in the next paragraph.

In Refs. [15,26], the dynamic bandwidth allocation mechanism was discussed with fixed cycle time by assigning equal time slot durations per ONU. Furthermore, the polling sequence of the ONUs is a traditional scheduling mechanism. The timeslot covers the data transmission period, RTT and control message processing time. Therefore, within the timeslot available, the data transmission duration was assigned as per the REPORT message and the propagation distance, which results in variation in the RTT [27,32,33]. In this case, the FILO/LASA methods can be made possible by considering equal idle times according to equal time slots as a reference, as discussed in Section 3.

In this work, the FILO/MLASA methods are limited to the static scenario. However, a detailed analysis of real-time traffic may be attempted in future work. One of the limitations of these scheduling methods is unpredictable traffic. The other limitation is a lesser network reach or a limited number of ONUs.

5 Conclusions

In this paper, a new polling method, namely, the FILO polling sequence, has been proposed for the 10G-EPON; it has provided a unique idle time for each ONU due to the modification incorporated in the polling sequence. This has resulted in ONUs attaining the required idle time threshold

for sleep mode from doze mode. The effective idle time duration for the FILO sequence under CBR traffic has been discussed. Among the types of ONUs, namely, VCSEL and DFB laser ONUs, the observed power cumulative variation was the same. The FILO DFB method outperformed the LASA method in both power cumulative and energy savings. The MLASA method had the best power cumulative among the different algorithms considered and the minimum delay compared to that of the other methods. On the other hand, the MLASA method with the DFB laser ONU had the least energy savings due to the lesser time duration in the power saving modes when compared to the other methods. Therefore, the MLASA can be selected to meet the requirements for which the power conservation matters most rather than for how much time the ONU is kept in the corresponding power saving mode. On the other hand, FILO remained moderate in terms of energy savings as well as power conservation and had the maximum energy savings value with the DFB laser. However, the percentage energy savings for FILO with the VCSEL ONU resulted in a better value than did the traditional fixed polling sequence throughout the idle time range considered. In terms of idle time assignments, the selection of the FILO method for uneven idle times to the ONUs and MLASA is for the other case. Additionally, the proposed polling sequences may be extended as a future work for ring topologies with CBR traffic.

References

1. Baliga J, Ayre R, Hinton K, Sorin W V, Tucker R S. Energy consumption in optical IP networks. *Journal of Lightwave Technology*, 2009, 27(13): 2391–2403
2. Kramer G. *Ethernet Passive Optical Networks*. Ontario: McGraw-Hill, 2005
3. Li Z, Yi L, Hu W. Key technologies and system proposals of TWDM-PON. *Frontiers of Optoelectronics*, 2013, 6(1): 46–56
4. Kramer G, Pesavento G. *Ethernet passive optical network (EPON): building a next-generation optical access network*. *IEEE Communications Magazine*, 2002, 40(2): 66–73
5. Systems DITU-T G Suppl. 45. 45: 2009
6. Wong E, Mueller M, Dias M P I, Chan C A, Amann M C. Energy-efficiency of optical network units with vertical-cavity surface-emitting lasers. *Optics Express*, 2012, 20(14): 14960–14970
7. Zhang L, Yu C, Guo L, Liu Y. Energy-saving mechanism based on double-sleep-state algorithm and dynamic double-threshold receiver selection in EPON. *Optik (Stuttgart)*, 2013, 124(18): 3655–3664
8. Li C, Guo W, Hu W, Xia M. Energy-efficient dynamic bandwidth allocation for EPON networks with sleep mode ONUs. *Optical Switching and Networking*, 2015, 15: 121–133
9. Liu C P, Wu H T, Ke K W. The QoS provisioning tri-mode energy saving mechanism for EPON networks. *Photonic Network Communications*, 2017, 33(1): 26–38
10. Newaz S H S, Cuevas A, Lee G M, Crespi N, Choi J K. Evaluating energy efficiency of ONUs having multiple power levels in TDM-

- PONs. *IEEE Communications Letters*, 2013, 17(6): 1248–1251
11. Nikoukar A, Hwang I S, Liem A T, Wang C J. QoS-aware energy-efficient mechanism for sleeping mode ONUs in enhanced EPON. *Photonic Network Communications*, 2015, 30(1): 59–70
 12. Aslam B R, Mahdaliza I S, Naseer Q K, Shah P M A, Zulkifli N. An energy efficient cyclic sleep control framework for ITU PONs. *Optical Switching and Networking*, 2018, 27: 7–17
 13. Hwang I S, Nikoukar A, Su Y M, Liem A T. Decentralized SIEPON-based ONU-initiated Tx/TRx energy-efficiency mechanism in EPON. *Journal of Optical Communications and Networking*, 2016, 8(4): 238–248
 14. Butt R A, Waqar A M, Faheem M, Idrus S M. Processing efficient frame structure for passive optical network (PON). *Optical Switching and Networking*, 2018, 30: 85–92
 15. Van D P, Valcarengli L, Dias M P, Kondepu K, Castoldi P, Wong E. Energy-saving framework for passive optical networks with ONU sleep/doze mode. *Optics Express*, 2015, 23(3): A1–A14
 16. Lv Y, Jiang N, Qiu K, Xue C. Energy-efficient load adaptive polling sequence arrangement scheme for passive optical access networks. *Journal of Optical Communications and Networking*, 2015, 7(6): 516–524
 17. Tan Z, Yang C, Wang Z. Energy evaluation for cloud RAN employing TDM-PON as front-haul based on a new network traffic modeling. *Journal of Lightwave Technology*, 2017, 35(13): 2669–2677
 18. Kantarci B, Mouftah H. Energy efficiency in the extended-reach fiber-wireless access networks. *IEEE Network*, 2012, 26(2): 28–35
 19. Shi L, Mukherjee B, Lee S S. Energy-efficient PON with sleep-mode ONU: progress, challenges, and solutions. *IEEE Network*, 2012, 26(2): 36–41
 20. Garfias P, De Andrade M, Tornatore M, Buttaboni A, Sallent S, Gutiérrez L. Energy-saving mechanism in WDM/TDM-PON based on upstream network traffic. *Photonics*, 2014, 1(3): 235–250
 21. Dixit A, Lannoo B, Colle D, Pickavet M, Demeester P. ONU power saving modes in next generation optical access networks: progress, efficiency and challenges. *Optics Express*, 2012, 20(26): B52–B63
 22. Pham V D, Valcarengli L, Chincoli M, Castoldi P. Experimental evaluation of a sleep-aware dynamic bandwidth allocation in a multi-ONU 10G-EPON testbed. *Optical Switching and Networking*, 2014, 14: 11–24
 23. Dourado D M, Ferreira R J L, de Lacerda R M, Duarte U R. Energy consumption and bandwidth allocation in passive optical networks. *Optical Switching and Networking*, 2018, 28: 1–7
 24. Wong S W, Valcarengli L, Yen S H, Campelo D R, Yamashita S, Kazovsky L. Sleep mode for energy saving PONs: advantages and drawbacks. In: *Proceedings of IEEE Globecom Workshop*. Honolulu: IEEE, 2009, 1–6
 25. Dias M P I, Wong E. Performance evaluation of VCSEL ONU using energy-efficient just-in-time dynamic bandwidth allocation algorithm. In: *Proceedings of Photonics Global Conference (PGC)*. Singapore: IEEE, 2012
 26. Dias M P I, Wong E. Sleep/doze controlled dynamic bandwidth allocation algorithms for energy-efficient passive optical networks. *Optics Express*, 2013, 21(8): 9931–9946
 27. McGarry M P, Reisslein M, Aurzada F, Scheutzwow M. Shortest propagation delay (SPD) first scheduling for EPONs with heterogeneous propagation delays. *Journal on Selected Areas in Communications*, 2010, 28(6): 849–862
 28. Hunsperger R G. *Distributed-Feedback Lasers*. In: *Integrated Optics*. Berlin: Springer, 1995, 226–243
 29. Li J, Zhong Z, Hua N, Zheng X, Zhou B. Balancing energy efficiency and device lifetime in TWDM-PON under traffic fluctuations. *IEEE Communications Letters*, 2017, 21(9): 1981–1984
 30. Rayapati B R, Rangaswamy N. Adaptive scheduling mechanism with variable bit rate traffic in EPON. *Journal of Optical Communications*, 2019, doi:10.1515/joc-2018-0219
 31. Frigui N E, Lemlouma T. Optimization of the upstream bandwidth allocation in passive optical networks using internet users' behavior forecast. In: *Proceedings of 22nd International Conference on Optical Network Design and Modeling*. Dublin: HAL, 2018, 59–64
 32. Buttaboni A, De Andrade M, Tornatore M A. Multi-threaded dynamic bandwidth and wavelength allocation scheme with void filling for long reach WDM/TDM PONs. *Journal of Lightwave Technology*, 2013, 31(8): 1149–1157
 33. Mercian A, McGarry M P, Reisslein M. Offline and online multi-thread polling in long-reach PONs: a critical evaluation. *Journal of Lightwave Technology*, 2013, 31(12): 2018–2028



Bhargav Ram Rayapati is a research scholar at Pondicherry University, Pondicherry. He received his B.Tech. degree in Electronics and Communication Engineering from Gudlavalluru Engineering College affiliated with Jawaharlal Nehru Technological University-Kakinada in 2011 and his M.Tech. degree in Electronics and Communication Engineering (with diversification in computers and communications) from Jawaharlal Nehru Technological University-Kakinada in 2014. He is currently working toward a Ph.D. degree in the Department of Electronics Engineering, Pondicherry University, Pondicherry, India. His current research interests are optical networks and energy-efficient technologies.



Nakkeeran Rangaswamy received his B.Sc. degree in Science and B.E. degree in Electronics and Communication Engineering from Madras University in 1987 and 1991, respectively, and his M.E. degree in Electronics and Communication Engineering (with diversification in optical communication) from Anna University in 1995. He received the Ph.D. degree from Pondicherry University in 2004. Since 1991, he has been working in the teaching profession. Presently, he is an associate professor at Pondicherry University. He is a life member of IETE, ISTE, OSI, and IE(I). Additionally, he is a senior member of IEEE and member of OSA, SPIE and IEICE. He has published more than 180 papers in national and international conference proceedings and journals. He has coauthored a book published by PHI. His areas of interest are optical communication, networks, antennas, electromagnetic fields, and wireless communication.