

# Microwave photonic filters based on optical semiconductor amplifier

Enming XU (✉)<sup>1</sup>, Peili LI<sup>1</sup>, Fei WANG<sup>2</sup>, Jianfei GUAN<sup>1</sup>

<sup>1</sup> School of Opto-Electronic Engineering, Nanjing University of Posts and Telecommunications, Nanjing 210046, China

<sup>2</sup> School of Mathematics and Physics, Chongqing University of Technology, Chongqing 400050, China

© Higher Education Press and Springer-Verlag Berlin Heidelberg 2011

**Abstract** Microwave photonic filters have been characterized by low loss, light weight, broad bandwidth, good tunability, and immunity to electromagnetic interference, and these filters can overcome inherent electronic limitations. Fiber-based filters are inherently compatible with fiber-optic microwave systems and can provide connectivity with built-in signal conditioning. This review paper presents developments of microwave photonic filters based on semiconductor optical amplifier in the last few years. Challenges in system implementation for practical application are also discussed.

**Keywords** microwave photonic, microwave filters, optical signal processing, semiconductor optical amplifier, cross-gain modulation

## 1 Introduction

Using photonic technology to realize microwave and millimeter-wave processing has attracted considerable attention in recent years [1–3]. Compared with traditional electronics-based microwave circuits, microwave photonic processing provides advantages such as low loss, light weight, broad bandwidth, good tunability and immunity to electromagnetic interference. Furthermore, it can break through so-called electronic bottleneck and has many potential applications in ultra-bandwidth wireless mobile communication, array phase radar, sensors of microwave and millimeter-wave, microwave and millimeter-wave signal processing. Microwave photonic processing not only provides the possibility of processing microwave and millimeter-wave signals directly in optical domain without optoelectronic conversion process, but also has the benefit

of being inherently compatible with fiber-based transmission system and can be incorporated into optical fiber network. Semiconductor optical amplifiers (SOAs) have been widely applied in all-optical signal processing [4–6]. The SOA also exhibits some advantages in microwave photonic filters, it can realize some microwave photonic filters with some characteristics that other components cannot realize. Some theoretical and experimental researches on microwave photonic filters based on SOAs have been presented and demonstrated.

In this paper, we describe some structures that can extend the performance of photonic signal processors. These include the methods to realize notch filter with flat passband in optical domain using cross-gain modulation (XGM) effect of the amplified spontaneous emission spectrum (ASE) of the SOA [7,8], techniques to obtain a high frequency selectivity using an improved structure with the ASE signal circulating in a loop, and methods to realize higher  $Q$  filter with free spectral range (FSR) increased in the way of the cascade.

## 2 Microwave photonic notch filters with flat passband

### 2.1 Fiber-Bragg-grating-based approach

The schematic diagram of the proposed SOA-based microwave photonic notch filter with flat passband [9] is shown in Fig. 1. The structure is based on a recirculating delay line (RDL) loop and a fiber Bragg grating (FBG). The RDL loop is comprised of an SOA followed by a tunable narrowband optical filter (TNOF) and an optical variable delay line (OVDL). The negative tap is generated using wavelength conversion based on the XGM of the ASE spectrum of the SOA. The converted signal is extracted out by the TNOF and is with radio frequency (RF) phase inversion of the pump signal. The converted

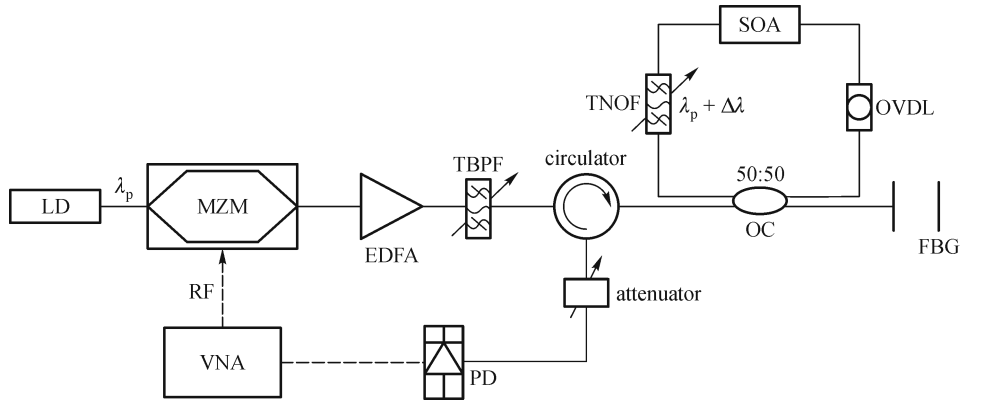

Fig. 1 SOA-based microwave photonic notch filter with flat passband

signal circulating in the RDL loop in counterclockwise direction realizes a bandpass frequency response with negative coefficients. A negative band-pass frequency response and a broadband all-pass frequency response realized by the signal directly reflected back by the FBG are synthesized to achieve a narrow notch frequency response with flat passband, which can excise interference with minimal impact on the wanted signal over a wide microwave range. Theoretical and measured responses of the proposed notch filter are shown in Fig. 2. The OVDL is used to realize the tunability of the filter.

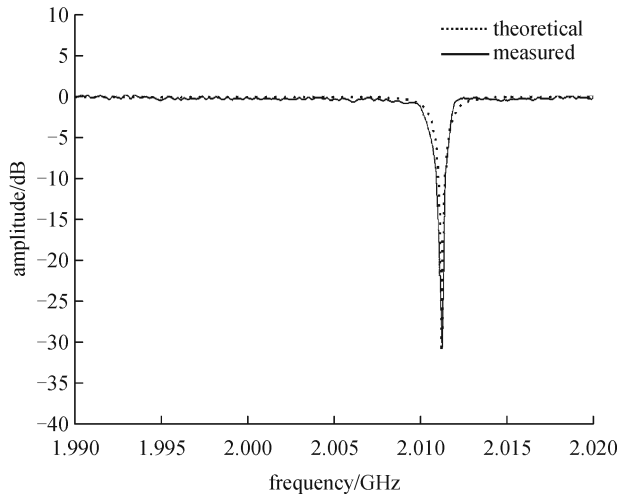

Fig. 2 Theoretical and measured responses of proposed microwave photonic notch filter

### 2.2 Simple SOA-based loop approach

The scheme diagram of a simple SOA-based microwave photonic notch filter [10] is shown in Fig. 3. The microwave notch filter with a flat passband is operated in optical domain. The filter is based on an RDL loop with an SOA followed by a TNOF. Converted signal serving as negative tap is generated through wavelength conversion

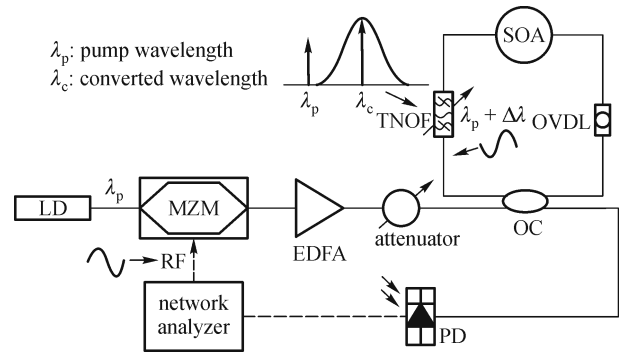

Fig. 3 Simple SOA-based microwave photonic notch filter

employing the XGM of the ASE spectrum of the SOA without a probe light. Converted signal circulating in the loop realize a bandpass response with negative coefficient. A narrow bandpass response with negative coefficients and a broadband all-pass response realized by the signal directly passes through the coupler are combined to achieve a narrow notch response with flat passband. The theoretical and measured responses of the proposed microwave photonic filter are shown in Fig. 4. Some humps are visible close to the notches, the reason is that the pump signal is not filtered out completely by the TNOF. Compared to the FBG-based structure, this structure does not need the FBG.

## 3 Microwave photonic filters with high Q

### 3.1 Conventional SOA-based loop approach

The conventional SOA-based bandpass filter [11] scheme is shown in Fig. 5. The filter is with a 2×2, 50:50 coupler, and the central wavelength of the TNOF is aligned with the pump signal wavelength. Its output is extracted at the 2×2, 50:50 coupler used to form the loop, and its measured frequency response using a vector network analyzer

(VNA) is shown in Fig. 6. This conventional bandpass filter structure has some drawbacks due to the ASE noise of the SOA, such as a limited  $Q$  factor of 193, a limited rejection ratio of 14 dB, and a limited shape factor of 22.6.

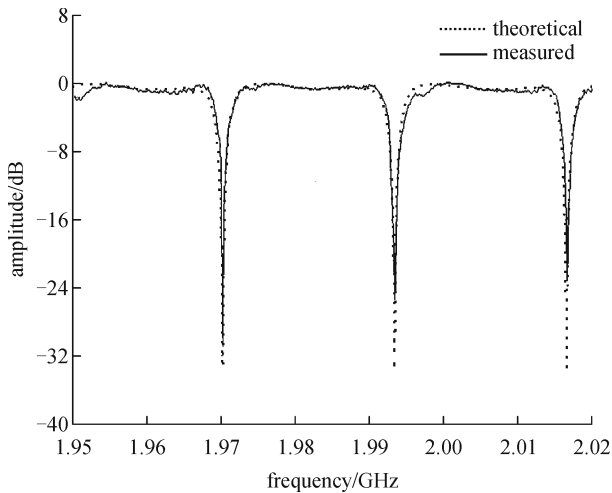

Fig. 4 Theoretical and measured responses of simple SOA-based microwave photonic notch filter

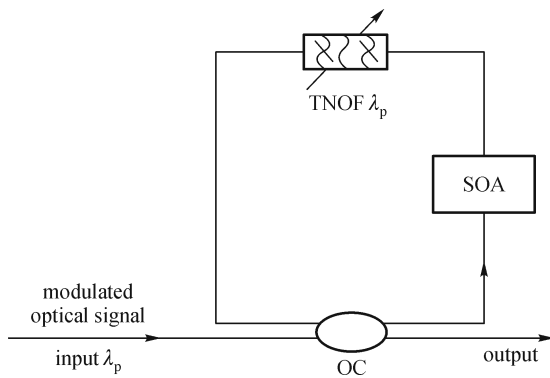

Fig. 5 Conventional SOA-based bandpass filter

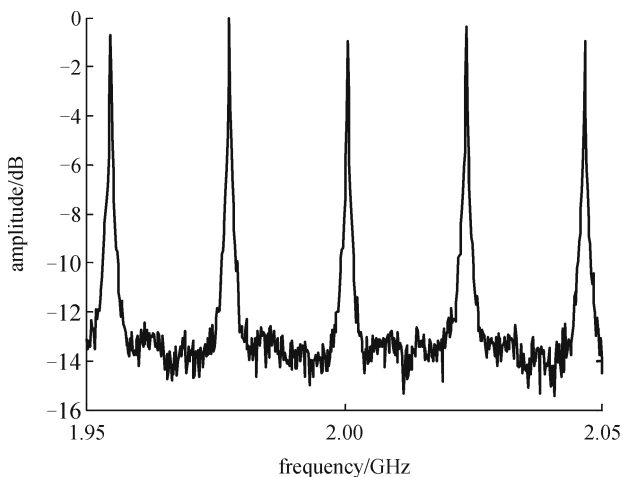

Fig. 6 Measured frequency response of conventional SOA-based bandpass filter

### 3.2 Novel SOA-based loop approach

The proposed novel SOA-based microwave bandpass filter [12] is shown in Fig. 7, which can realize high frequency-selectivity in optical domain. It is based on an RDL loop comprising an SOA, a TNOF and a  $1 \times 2$ , 10:90 optical coupler (OC). Converted signal serving as a negative tap is generated through wavelength conversion based on the XGM of the ASE spectrum of the SOA. Converted signal circulating in the RDL loop realizes a high  $Q$  factor frequency response after photo-detection using a photo-detector (PD). The  $1 \times 2$ , 10:90 OC is employed to extract 10% optical power from the loop as output, which is different from the previous bandpass filter structures. The residual pump signal not being filtered out by the TNOF realizes a weak all-pass response which makes the shape factor better. This novel filter structure can achieve high frequency-selectivity, i.e., high  $Q$  factor, high rejection ratio, and good shape factor simultaneously. In the case of the detuning of 4.12 nm and a given SOA bias current of 52.5 mA, the experimental results show a high  $Q$  factor of 543, a rejection ratio of 40 dB, and a shape factor of 15.4, as shown in Fig. 8.

## 4 Microwave photonic cascaded filters

### 4.1 IIR filter cascaded with FIR filter

The proposed hybrid filter structure [13] that combines both active and passive filters is shown in Fig. 9. The active filter is performed as an infinite impulse response (IIR) filter, and it is realized by RDL loop with SOA followed by a TNOF. Such an active filter is operated at the desired filter frequencies, which can achieve a much narrower 3-dB bandwidth response for a given gain margin, and the measured frequency response of the SOA-based IIR filter is shown in Fig. 10. The passive filter, connected after the active filter, is performed as a finite impulse response (FIR) filter, and it is realized by an unbalance Mach-Zehnder interferometer, which is used to select the desired filter frequencies and to suppress the intermediate peaks, and the measured frequency response of the FIR filter is shown in Fig. 11. The advantage of this structure is that its FSR can be doubled, while the 3-dB bandwidth of response peaks is maintained, and thus, the  $Q$  factor can be also doubled. Using this hybrid structure, the experimental result shows that the  $Q$  factor can be increased to 362, as shown in Fig. 12.

### 4.2 IIR filter cascaded with IIR filter

The schematic scheme of the IIR filter cascaded with IIR filter [14] is shown in Fig. 13. The cascaded filters are based on two active loops with an erbium-doped fiber amplifier (EDFA) and an SOA, respectively. The optical

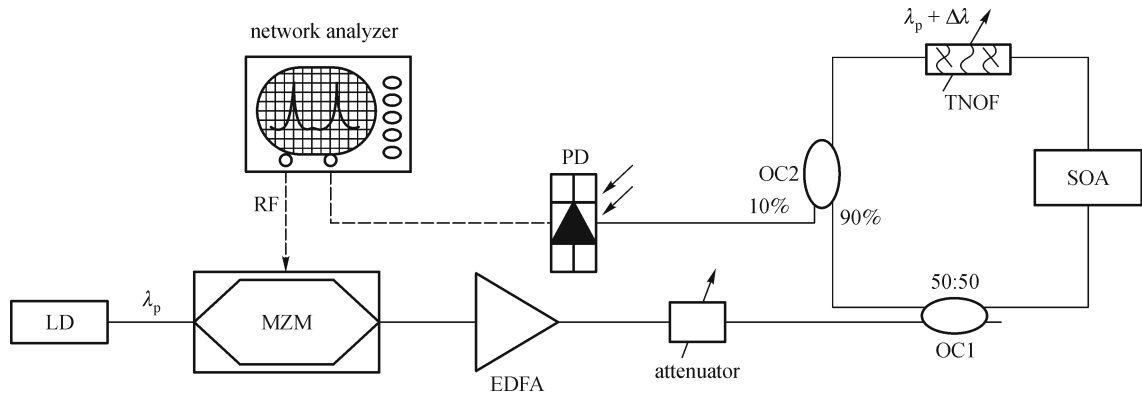

Fig. 7 Novel SOA-based microwave bandpass filter

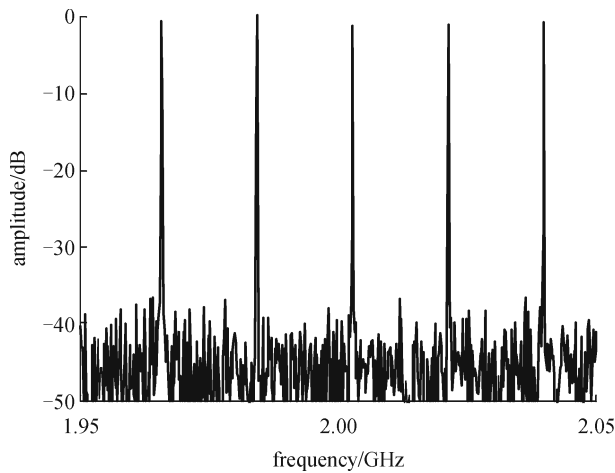

Fig. 8 Measured frequency response for detuning 4.12 nm at a given SOA bias current of 52.5 mA

source is a tunable laser diode (LD) centered at 1560 nm ( $\lambda_p$ ), whose coherence length is far smaller than the lengths

of the two active loops. The laser is externally modulated by a Mach-Zehnder modulator (MZM) driven by microwave signals from a VNA. Then the modulated optical signal is launched into the front active loop consisting of an EDFA (EDFA1), a tunable bandpass filter (TBPF), a 50:50 optical coupler (OC1) and an OVDL. An attenuator (ATT1) is used to control the input power of the front active loop. The TBPF centered at  $\lambda_p$  with a 3-dB bandwidth of 0.3 nm is used to reduce the ASE noise of the EDFA1. By properly controlling the input power, one can obtain a sharp bandpass filter response from the front active loop, as shown in the dotted line in Fig. 14.

The output power of the front active loop filter is further adjusted by an EDFA (EDFA2) and an attenuator (ATT2) before entering into the back active loop, which consists of an SOA, an optical bandpass filter (BPF) centered at  $\lambda_p + \Delta\lambda$ , a 50:50 optical coupler (OC2) and a 10:90 optical coupler (OC3). The ASE spectrum of the SOA is inversely modulated by the pump signal due to the XGM effect; therefore, the modulation information at the pump wavelength  $\lambda_p$  will be inversely copied into the whole

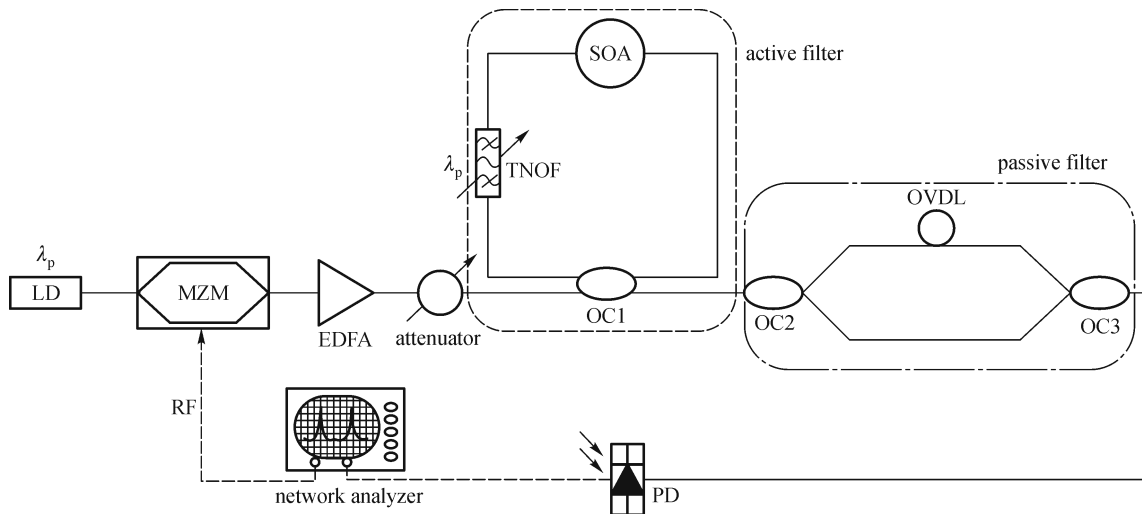

Fig. 9 Schematic scheme of hybrid filter

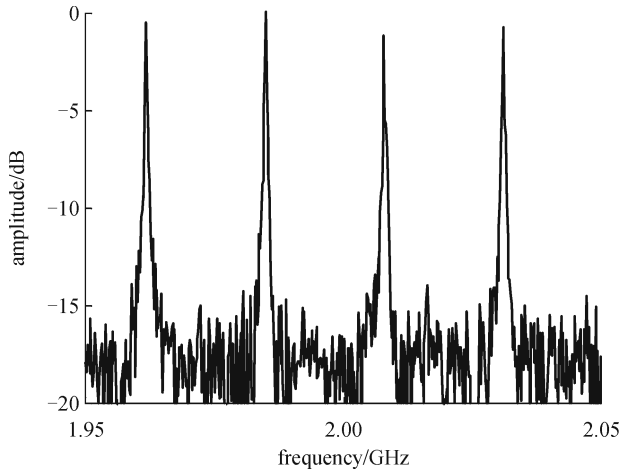

Fig. 10 Measured frequency response of IIR filter

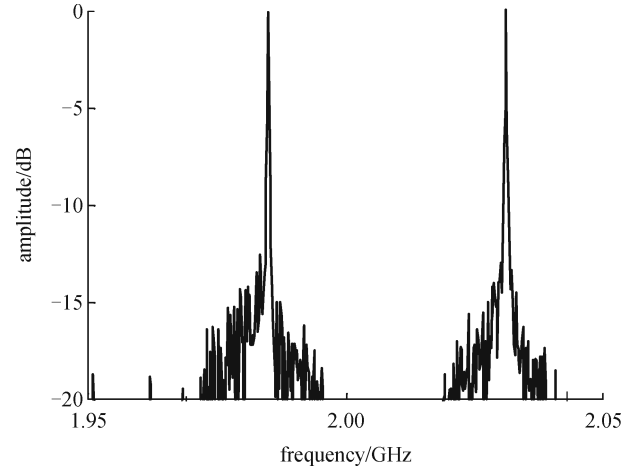

Fig. 12 Measured frequency response of hybrid filter

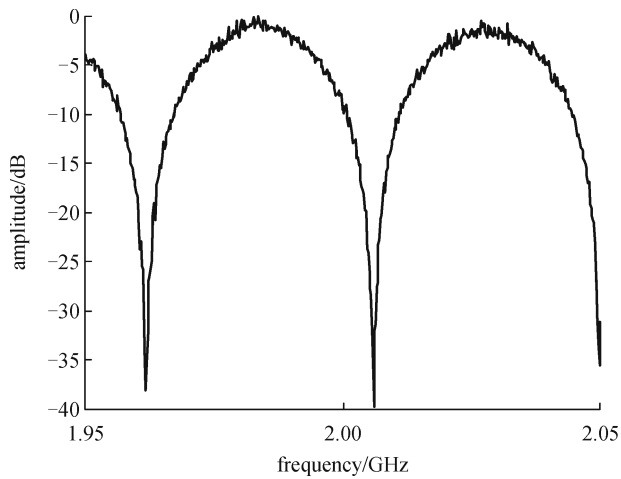

Fig. 11 Measured frequency response of FIR filter

ASE spectrum. The BPF with a 3-dB bandwidth of 1.2 nm is centered at 1557.8 nm, detuning from the pump wavelength about 2.2 nm. The BPF here is used to extract out the converted signal from the whole ASE spectrum.

With the OC3, 10% optical power is taken out from the back active loop while the residual 90% power is kept in the amplified loop and delayed to obtain the subsequent recursive taps. At a given SOA current, by properly adjusting the ATT2, one can obtain a high  $Q$  frequency response for the converted signal in the back active loop, as shown in the solid line in Fig. 14.

The interference among the signals of different taps from the cascaded IIR filter is avoided here through the wavelength conversion in the back IIR filter. In this way, we achieve stable transfer characteristics for the cascaded IIR filter. The FSR of the front IIR filter is designed to be different from that of the back one; thus, the FSR of the cascaded filter is the least common multiple of that of each IIR filter, as shown the measured frequency response of the cascaded filter in Fig. 15. So one can significantly increase the FSR of the cascaded filter by properly choosing the FSR difference of the two IIR filters. The FSR of the front IIR filter can be adjusted by an OVDL in the front loop. With Vernier effect, one can shift the peaks of the front IIR filter to match a desired peak of the back IIR filter to realize tunability.

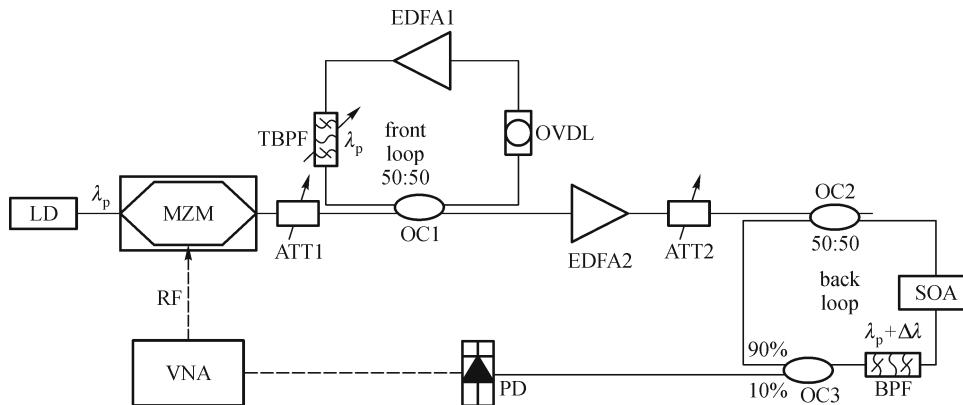

Fig. 13 Schematic scheme of IIR filter cascaded with IIR filter

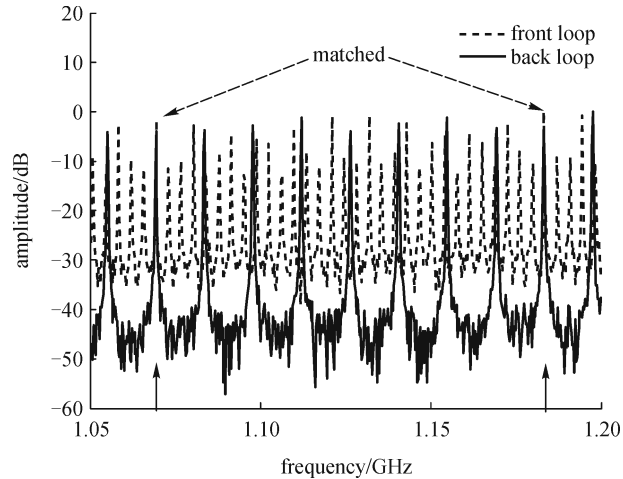

Fig. 14 Measured frequency responses of front IIR filter and back IIR filter

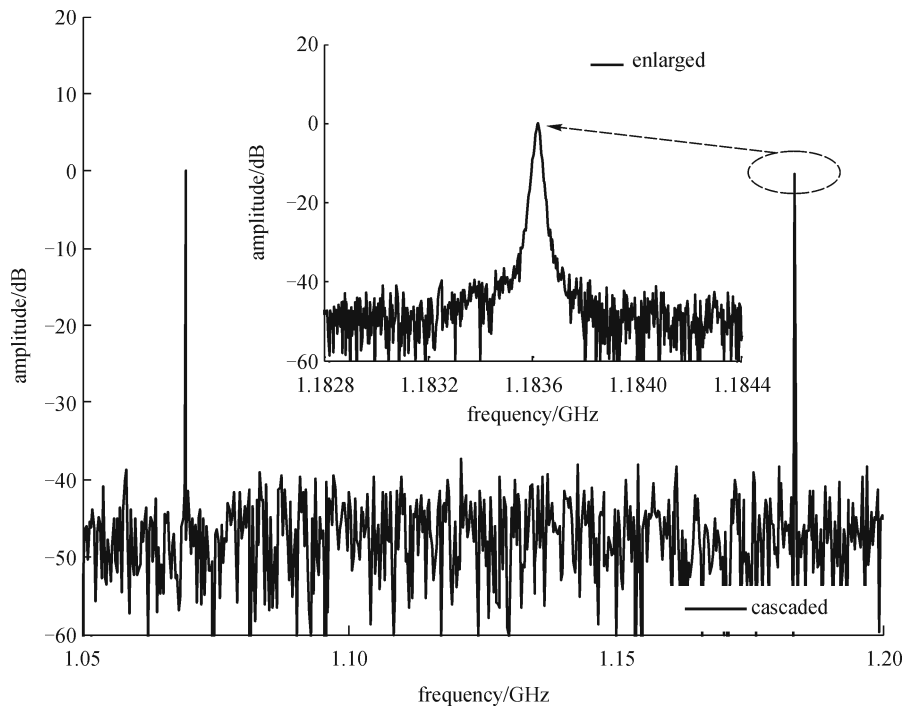

Fig. 15 Measured frequency response of cascaded filter

## 5 Discussion and conclusion

Photonic techniques provide many advantages over its electronic counterpart for processing microwave and millimeter-wave signals for applications, such as broadband wireless access networks, radar, phased-arrayed antennas, sensor networks, and satellite communications. In this paper, an overview about the developments of microwave photonic filter based on SOA in recent years has been presented. In addition, the SOA can be used for photonic generation of microwave and millimeter-wave

signals [15], and ultra-wideband (UWB) signal [5]. The key challenge in implementations of these systems for practical applications is the large size and high cost of the systems. The microwave photonics systems in the past few years were mainly based on discrete microwave photonic components, which make the systems bulky, heavy, and costly. Overcoming these limitations is to use photonic integrated circuits.

**Acknowledgements** This work was supported by the National Basic Research Program of China (No. 2006CB302805), the National Natural

Science Foundation of China (Grant Nos. 60707006 and 61007064) and the Natural Science Foundation of the Jiangsu Higher Education Institutions of China (09KJB510009).

---

## References

1. Capmany J, Novak D. Microwave photonics combines two worlds. *Nature Photonics*, 2007, 1(6): 319–330
2. Yao J P. Microwave photonics. *Journal of Lightwave Technology*, 2009, 27(3): 314–335
3. Capmany J, Ortega B, Pastor D. A tutorial on microwave photonic filters. *Journal of Lightwave Technology*, 2006, 24(1): 201–229
4. Dong J J, Zhang X L, Xu J, Huang D X, Fu S N, Shum P. 40 Gb/s all-optical NRZ to RZ format conversion using single SOA assisted by optical bandpass filter. *Optics Express*, 2007, 15(6): 2907–2914
5. Dong J J, Zhang X L, Xu J, Huang D X, Fu S, Shum P. Ultrawideband monocycle generation using cross-phase modulation in a semiconductor optical amplifier. *Optics Letters*, 2007, 32(10): 1223–1225
6. Xu J, Zhang X L, Dong J J, Liu D M, Huang D X. High-speed all-optical differentiator based on a semiconductor optical amplifier and an optical filter. *Optics Letters*, 2007, 32(13): 1872–1874
7. Yi X K, Wei F, Hong N J, Chao L. Tunable microwave filter design using wavelength conversion technique and high dispersion time delays. *IEEE Photonics Technology Letters*, 2001, 13(8): 857–859
8. Liu D M, Hong N J, Chao L. Wavelength conversion based on cross-gain modulation of ASE spectrum of SOA. *IEEE Photonics Technology Letters*, 2000, 12(9): 1222–1224
9. Xu E M, Zhang X L, Zhou L N, Zhang Y, Huang D X. All-optical microwave notch filter with flat passband based on semiconductor optical amplifier. *Optics Communications*, 2009, 282(12): 2297–2300
10. Xu E M, Zhang X L, Zhou L N, Zhang Y, Huang D X. A simple microwave photonic notch filter based on a semiconductor optical amplifier. *Journal of Optics A: Pure and Applied Optics*, 2009, 11(8): 085405
11. Zhou L N, Zhang X L, Xu E M, Huang D X.  $Q$  value analysis of a first-order IIR microwave photonic filter based on SOA. *Acta Physica Sinica*, 2009, 58(2): 1036–1041
12. Xu E M, Zhang X L, Zhou L N, Zhang Y, Yu Y, Li X, Huang D X. All-optical microwave filter with high frequency selectivity based on semiconductor optical amplifier and optical filter. *Journal of Lightwave Technology*, 2010, 28(16): 2358–2365
13. Xu E M, Zhang X L, Zhou L N, Zhang Y, Huang D X. Hybrid active-passive microwave photonic filter with high quality factor. *Chinese Physics Letters*, 2009, 26(9): 094208
14. Xu E M, Zhang X L, Zhou L N, Zhang Y, Yu Y, Li X, Huang D X. Ultrahigh- $Q$  microwave photonic filter with Vernier effect and wavelength conversion in a cascaded pair of active loops. *Optics Letters*, 2010, 35(8): 1242–1244
15. Zhou J L, Xia L, Chen X P, Dong X P, Shum P. Photonic generation of tunable microwave signals by beating a dual-wavelength single longitudinal mode fiber ring laser. *Applied Physics B: Lasers and Optics*, 2008, 91(1): 99–103