

Review of fiber Bragg grating sensor technology

Jinjie CHEN, Bo LIU (✉), Hao ZHANG

Key Laboratory of Opto-Electronic Information and Technology, Ministry of Education, Institute of Modern Optics, Nankai University,
Tianjin 300071, China

© Higher Education Press and Springer-Verlag Berlin Heidelberg 2011

Abstract The current status of the fiber Bragg grating (FBG) sensor technology was reviewed. Owing to their salient advantages, including immunity to electromagnetic interference, lightweight, compact size, high sensitivity, large operation bandwidth, and ideal multiplexing capability, FBG sensors have attracted considerable interest in the past three decades. Among these sensing physical quantities, temperature and strain are the most widely investigated ones. In this paper, the sensing principle of FBG sensors was briefly introduced first. Then, we reviewed the status of research and applications of FBG sensors. As very important for industrial applications, multiplexing and networking of FBG sensors had been introduced briefly. Moreover, as a key technology, the wavelength interrogation methods were also reviewed carefully. Finally, we analyzed the problems encountered in engineering applications and gave a general review on the development of interrogation methods of FBG sensor.

Keywords fiber Bragg grating (FBG) sensors, multiplexing, networking, interrogation

1 Introduction

Almost three decades have passed since the inauguration of research on fiber-optic sensors. Various ideas have been proposed, and a good variety of techniques have been developed for numerous measurands and applications. To date, some types of optical fiber sensors have been commercialized, but it should be noted that, among the various techniques that have been investigated, only a limited number of techniques and applications have been commercialized successfully.

Fiber optical sensors based on fiber Bragg gratings (FBGs) or FBG arrays have been widely applied in the measurement of physical, chemical, biomedical, and

electrical parameters, especially for structural health monitoring in civil infrastructures, aerospace, energy, and maritime areas, where the information of measurands are usually encoded by the Bragg wavelength shift of FBGs. The above sensing approach has many advantages, such as compactness, immunity to electromagnetic interference, rapid response for real time monitoring, and high sensitivity to external perturbations [1–3].

In this paper, we presented a general review on the sensing principle of FBG sensors, applications of FBG sensors, and interrogation methods developed in recent years.

2 Sensing principle of FBG

The sensing principle of an FBG is based on a periodic perturbation of the refractive index along the fiber length induced by exposure of the core under illumination of an intense optical interference pattern. The refractive index perturbation in the core is a periodic, similar to a volume hologram or a crystal lattice that works as a stop-band filter. A narrow band of the incident optical field within the fiber is reflected by successive coherent scattering from the index variations. The strongest interaction or mode-coupling occurs at the Bragg wavelength, which is given by Ref. [4].

$$\lambda_B = 2n_{\text{eff}}\Lambda, \quad (1)$$

where λ_B is the Bragg wavelength of FBG, n_{eff} is the effective refractive index of the fiber core, and Λ represents the grating period. Any change of n_{eff} or Λ will cause a wavelength shift in FBG, which can be used for the measurement of various physical parameters, including temperature, strain, voltage/current, index of refraction, etc.

3 Applications of FBG sensors

The sensing mechanism of fiber grating sensors could be

attributed to the change of the grid period or effective index of fiber grating in response to external perturbations, such as stress, strain, temperature, etc., which causes the Bragg wavelength of the fiber grating shift. Hence, by monitoring the Bragg wavelength shift, the value of various measurands, such as strain, temperature, displacement, current, voltage, flow, vibration intensity, acceleration, etc., could be determined. Strain and temperature measurements with FBG are the most common sensing applications. Typical strain responses of the Bragg wavelength are ~ 0.64 , ~ 1 , and ~ 1.2 pm/ $\mu\epsilon$ ($\mu\epsilon$ = micro-strain) for the Bragg wavelength of around 830, 1300, and 1550 nm, respectively [5]. Despite that the values are dependent on FBG types, their typical temperature response counterpart are ~ 6.8 , ~ 10 , and ~ 13 pm/ $^{\circ}\text{C}$, respectively [6]. In addition to the common advantages of fiber sensors, this wavelength interrogation method provides robustness to noise and power fluctuation and also enables wavelength-division-multiplexing of a great amount of FBG sensors. Hence, multipoint sensors can be easily realized using this technique [7]. In the next section, we will introduce some typical FBG sensors in a proper order.

Since the Bragg wavelength of FBG is sensitive to both strain and temperature, discrimination between them is a matter that has to be considered to achieve dual-parameter measurement. Many efforts have been focused on this topic, and various solutions have been proposed, including the use of two FBGs with one to measure only temperature [8], two FBGs with one bonded with some substrate [9] to achieve different sensitivity, an FBG combined with a long-period grating [10], a superstructure FBG [11], a chirped FBG whose reflection bandwidth is not sensitive to temperature [12], or an FBG with two wavelengths that respond differently to strain and/or temperature [13,14]. The first technology is a straight forward but very practical approach, in which another FBG that is isolated from the influence of one parameter, e.g., temperature, is placed near the sensing FBG. A schematic diagram of this method is shown in Fig. 1.

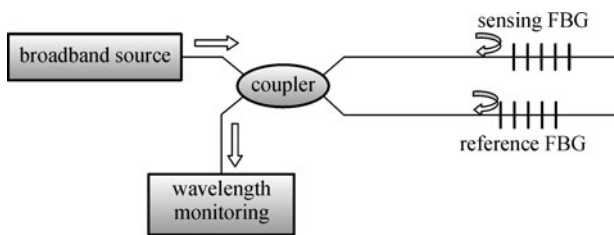

Fig. 1 Schematic diagram of strain and temperature FBG sensors

FBG-based displacement sensors have been widely used in buildings, bridges, mechanical structure, vehicle, and aircraft. Moreover, research on using FBG sensors to monitor coal seam location to ensure the mine safety and mountain sports to prevent landslides has great significance to us. A novel FBG-based displacement sensor

system for the measurement of static/dynamic and out-of-plane/in-plane displacement is illustrated in Fig. 2. The gratings will stretch or shrink as displacement of the plate changes. One segment of FBG1 is attached to a vertical translation stage, and its opposite end is glued to a point on the test specimen to be measured. FBG1 sensor is tensed by the translation stage to keep the fiber straight before measurement. Therefore, it is able to withstand compression and tension translated from the specimen. Since the Bragg wavelength is linearly proportional to the longitudinal strain over the grating, FBG1 shows the pointwise dynamic out-of-plane displacement when the detected point moves along the vertical direction based on the proposed setup method for the FBG, and this sensor system can measure the dynamic displacement within the range of 200 to 5000 nm with a vibration frequency of up to at least 20 kHz [15].

Owing to its natural immunity to electromagnetic interference, FBG-based sensors play an important role in generation and power transmission of electricity. Moreover, in recent years, within the oil and gas industry, more emphasis is being put on increasing the efficiency and reliability of oil extraction processes. Due to the lack of suitable instrumentation that would be capable of measuring current and voltage waveforms over long distances in a hostile environment, an entirely new measurement approach is required to provide instant information about off-optimal running of the motor in order to mitigate these effects by making appropriate adjustments at the motor controller site. FBG-based voltage sensor like what was proposed by Niewczas, et al. in Ref. [16] can wonderfully meet the requirements. The hybrid voltage sensor employs a piezoelectric transducer that is used to convert an input voltage signal into an internal strain that is detected by an FBG bonded to the piezoelectric transducer (Fig. 3). The voltage rating of the presented device could be as low as 500 V due to the use of a multilayer piezoelectric stack as the primary voltage-to-strain transducer. This enables the use of such sensors across a wider range of electronic stability program (ESP) applications, which often have subkilovolt voltage ratings. Reference [17] presents a method to compensate the effects of hysteresis experienced by a hybrid piezoelectric fiber optic voltage sensor that may be useful in practical application.

Accelerometer is an important sensor used for shock and antivibration of machinery, vehicles, ships, and earthquake monitoring, inertial navigation, and guidance systems [18]. Figure 4 shows a schematic diagram of a novel FBG accelerometer on the basis of cantilever. By detecting the shift of Bragg wavelength of FBG that adhered to the central axis of the cantilever whose top is connected with a mass of m , one can calculate the acceleration to be measured. After several experiments were repeated, this novel FBG acceleration sensor was demonstrated to have a measurement accuracy of 0.01 g, measurement range

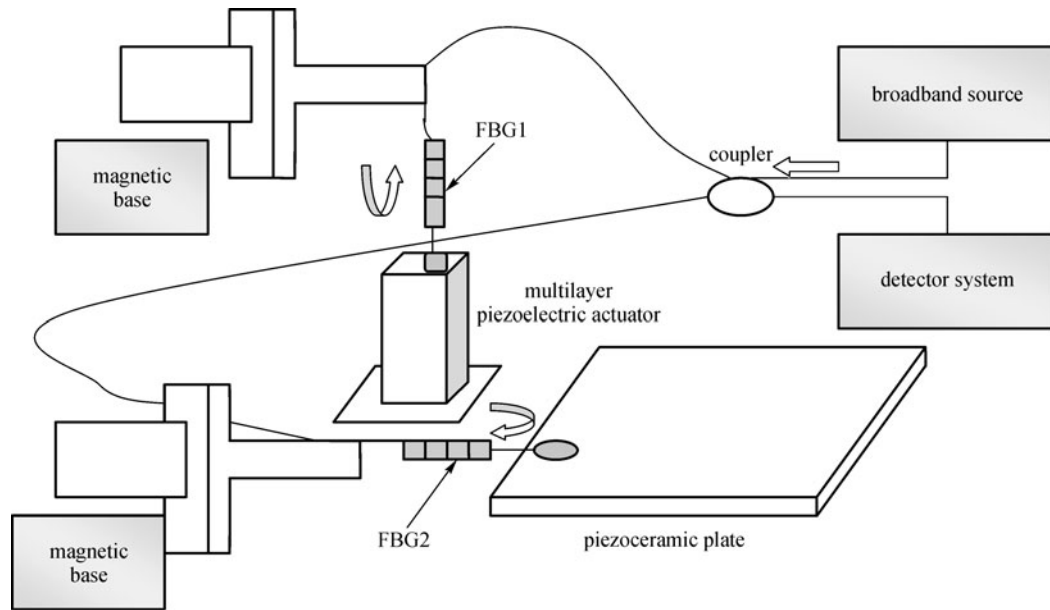

Fig. 2 Schematic diagram of FBG displacement sensors

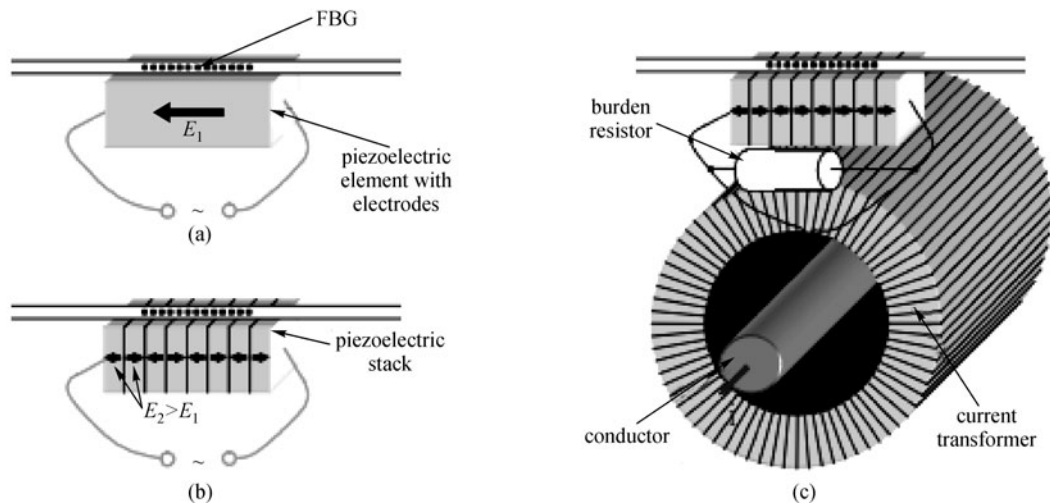

Fig. 3 Conceptual diagrams of optical voltage and current sensors in Ref. [16]. (a) Piezoelectric voltage sensor; (b) voltage sensor with increased sensitivity due to parallel electrical connection of individual piezoelectric stack elements; (c) current sensor employing voltage sensor with additional current transformer

of ± 10 g, and the maximum response frequency was 100 Hz.

A novel two-dimensional (2-D) clinometer by attaching two FBGs on a deliberately designed pendulum consisting of a tapered cylindrical beam and a mass was reported in Ref. [19]. The FBGs are chirped by the inclination-induced nonuniform strain fields. The inclination information is encoded by the reflected optical powers of the two FBGs. A schematic diagram of the proposed FBG clinometer is illustrated in Fig. 5. Two FBGs were glued on the surface of the tapered part of the beam at the same height along the

generatrix direction and separated by one fourth of the circumference of the beam from each other. When the clinometer setup is inclined at some angle, the beam is bent, and a nonuniform strain field is produced on the surface of the tapered part of the beam along the generatrix direction. The two FBGs were therefore chirped, and their bandwidths and reflected optical powers are changed. The achieved sensitivity is up to 1.96 W/($^{\circ}$) over a range from -4° to 4° , and the accuracy is 0.125° . Benefitting from the simple demodulation method and the inherently temperature-insensitivity of the sensing signal, the proposed

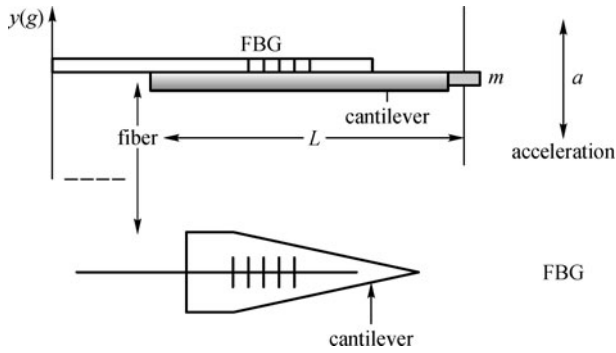

Fig. 4 Schematic diagram of novel acceleration FBG sensor

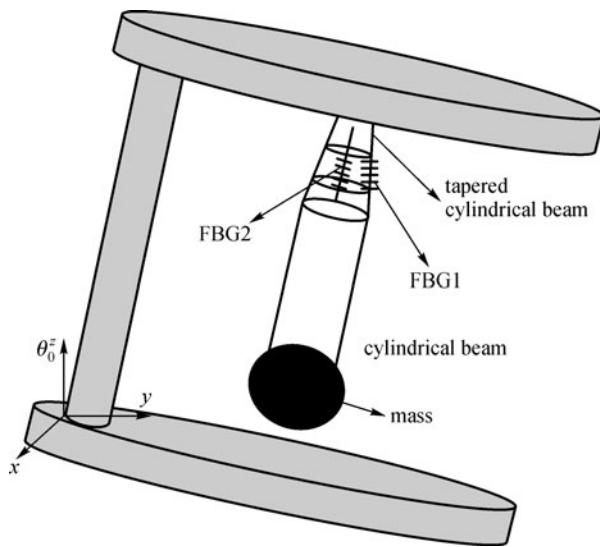

Fig. 5 Schematic diagram of clinometer proposed in Ref. [19]

pendulum clinometer is cost-efficient and independent of temperature.

In the petroleum, chemical industry, metallurgy, nuclear power plants, and other occasions, the flow detection system of a variety of explosive liquid and gas using fiber-optic grating sensor has natural insulation, antielectromagnetic interference, and other essential security features, with advantages like anticorrosion and small size. Vortex flow meter has become a common flow meter because of its simple structure, firmness, suitability to many kinds of liquid and gas, high accuracy, wide measuring range, and small pressure loss. In Ref. [20], a flow measuring system based on vortex whistler technology and FBG sensor is proposed. When the flow velocity of the measured body fluid through the vortex generator exceeds a certain threshold, two vortices appear side by side with an opposite direction to each other, whose frequency is proportional to flow velocity [21]. A cantilever with an FBG lodged on the central axial line is placed after the vortex body, forced vibration frequency of which equals to that of vortices. By monitoring the changing frequency of

Bragg wavelength, flow velocity can be obtained (Fig. 6). Experimental results show that the sensor has a measuring range of 0–25 L/min and an accuracy of 0.5% full scale (F.S).

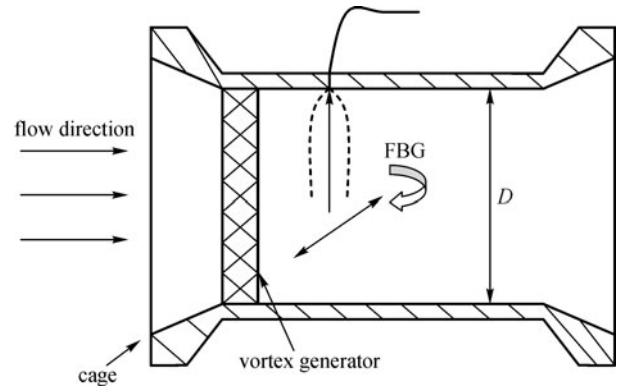

Fig. 6 Schematic diagram of flow-meter proposed in Ref. [20]

FBG-based vibration sensor is often used to monitor the oil and gas pipelines; hence, distributed sensors network is more common. Its principle is very similar to that of FBG displacement sensor, and more details can be obtained in Refs. [22] and [23].

4 Multiplexing and networking of FBG sensors

In recent years, research and development of quasi-distributed sensing technology and sensor network technology based on fiber grating sensors have attracted considerable interest, because the wavelength of individual FBG sensor is able to carry the measurand information of different positions. Since some tested objects contain more than one measurement point and sometimes possess a continuous distribution such as temperature field, stress field, etc., in order to obtain a complete information of tested objects; using distributed sensing technology to build up the sensor networks is indispensably required. In some cases, quasi-distributed FBG sensors still may not meet the engineering demands, and for this reason, people developed FBG sensor networks, which employ wavelength division multiplexing, time division multiplexing, space division multiplexing, and code division multiplexing techniques to establish the linear array, planar array, and body array according to specific engineering demand.

A quasi-distributed sensor network is shown in Fig. 7. Great amount of gratings with different Bragg wavelengths are inscribed in a single fiber, and these gratings are spatially separated from one another with certain interval. By addressing wavelength division, one can acquire the information of different positions along the fiber axis.

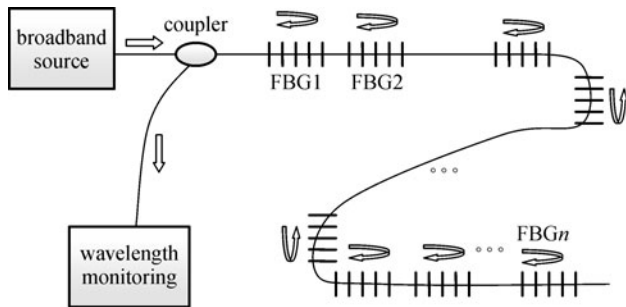

Fig. 7 Schematic diagram of quasi-distributed FBG sensor network

In Fig. 8, it can be seen that networking of FBG sensors realizes an intensive measurement of the tested field. Only one light source is required, and the same interrogation system is employed for different FBG sensors, which effectively reduces the system cost.

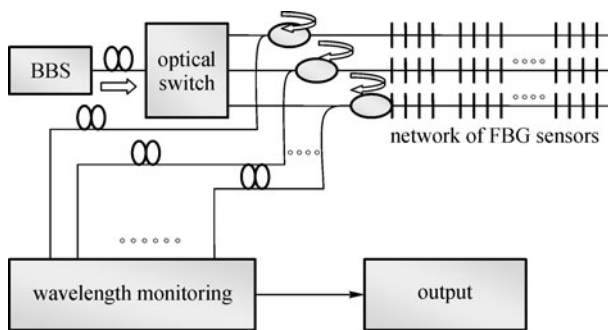

Fig. 8 Schematic diagram of FBG sensor network (BBS: broadband light source)

As mentioned above, the discrimination of the measurement of temperature and strain is a key problem in the implementation of distributed FBG sensing network; hence, many efforts have been made to solve this problem, such as the use of pair of FBGs with one to measure only temperature, an FBG with two wavelengths that respond differently to strain and/or temperature, an FBG insensitive to strain or temperature with special package, two FBGs with one bonded with some substrate to achieve different sensitivity, an FBG combined with a long-period grating, and a superstructure FBG or a chirped FBG whose reflection bandwidth is not sensitive to temperature. In many application occasions, FBG sensors have to compete with other mature sensing technologies, such as electronic measurements. To appeal to users already accustomed to conventional well-developed technologies, the superiority of optical fiber grating sensors over other techniques needs to be clearly demonstrated. Typical users simply require sensor systems with good performances and reasonable cost except for very special uses. Hence, FBG sensor

systems should be available for a complete sensing procedure including detecting and signal-processing electronics. Multiplexing and networking is one of the most effective ways to economize the system cost as mentioned above [24–28].

5 Interrogation methods of FBG sensors

Demodulators or interrogation systems are required for FBG sensors. FBG demodulation technique has become an important research field and the main factor that baffles the application of FBG sensor. Demodulation of FBG wavelength plays an important role that extracts measurement information from the optical signals collected from the sensor heads. The measurand information is typically encoded in the shift of Bragg wavelength, and hence, interrogators are typically expected to readout the wavelength shift and provide measurement data. Optical spectrum analyzers are not suitable for practical sensor systems because they are expensive, and their wavelength scanning speed is too slow. To detect the wavelength shift of fiber grating, people have proposed a wide range of wavelength interrogation methods, which can be generally classified into the following categories including interference demodulation, tunable filters demodulation, tunable laser demodulation, etc. [29].

5.1 Interference interrogation methods

Interference interrogation converts the Bragg wavelength shift of FBG into the phase variation of interferometers, such as Michelson, Mach-Zehnder (M-Z), and Sagnac interferometers. The interferometer is optimized to possess a particular optical path difference (OPD) between the two interference arms and operates at a static state, and the wavelength shift of the FBG signal could be converted into the phase change of the sensing signal and detected by a phase meter.

5.1.1 Michelson interferometer method

Bragg wavelength of FBG is incident into a nonequilibrium scanning Michelson interferometer, one arm of which is wrapped around a piezoelectric transducer (PZT) driven by the sawtooth wave. The interference signal is transformed into electric signal processed together with sawtooth wave using a phase detection module. One can obtain the measurement information by monitoring the interferometric phase variation induced by the wavelength shift [30]. This method has a fast detection speed, high sensitivity, and resolution, making it good candidate for applications in high-frequency detection systems. However, it is vulnerable to environmental perturbations, such as temperature and vibration fluctuations, which greatly limits its application scope [31,32] (Fig. 9).

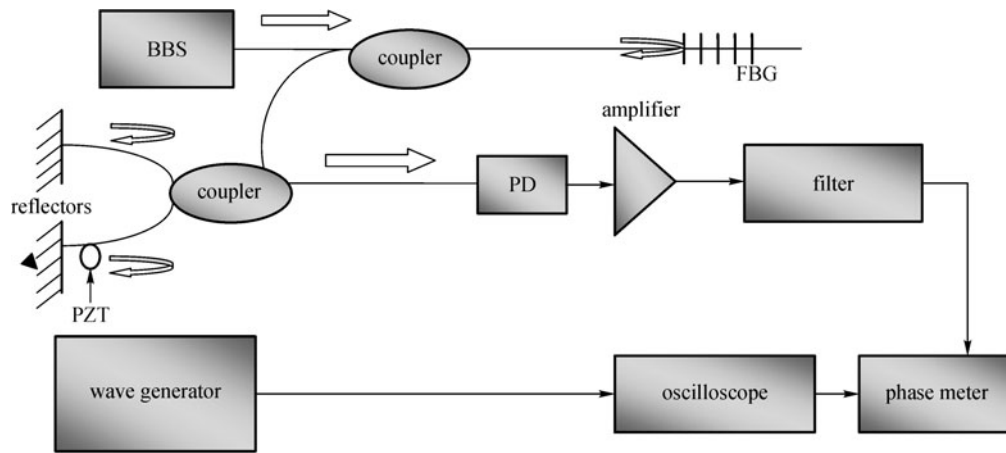

Fig. 9 Schematic diagram of Michelson interferometer method (PD: photo detector)

5.1.2 Nonequilibrium M-Z interferometer method

This method was proposed by Kersey for the first time in 1992 [33]. Light from broadband light source (BBS) incidents upon the FBG through a coupler, and the reflection light enters the two arms of the nonequilibrium M-Z interferometer formed by cascading two 3-dB couplers. Bragg wavelength shift of the FBG carrying the measurand information will cause a phase variation of the M-Z. It has several advantages, such as rapid response and high resolution, which makes it suitable for dynamic measurement despite its vulnerability to the external parameters, such as temperature and vibration. The sensitivity of this method achieves $0.6 \text{ n}\epsilon/\sqrt{\text{Hz}}$ for 500 Hz (Fig. 10).

5.2 Tunable-filter-based interrogation

By utilizing narrow band tunable filters, such as Fabry-Pérot (F-P) filter, acousto-optic tunable filter (AOTF), or an FBG-based optical filter, reflection wavelength of the FBG can be easily detected. The output signal could be regarded

as a convolution between the transfer function of the filter and the FBG reflection spectrum. Interrogation systems based on the scanning technique are sensitive to the intensity fluctuation in the sensing signal. Thus, it is not suitable for applications where fast and large dynamic range interrogation is required.

5.2.1 F-P-filter-based interrogation

F-P filtering interrogation is most commonly used in engineering applications. By fixing F-P in PZT, the driven voltage of PZT is adjusted to scan the wavelength and then record the relevant spectrum. Through a dedicated peak search algorithm, reflection wavelength of FBG could be detected, and thus, the measurand information is obtained [34]. Its advantages, such as compactness, good stability, and high resolution, make it a better interrogation solution. However, it is relatively rather expensive for commercial use (Fig. 11).

5.2.2 AOTF-based interrogation

AOTF have attracted considerable research interest owing

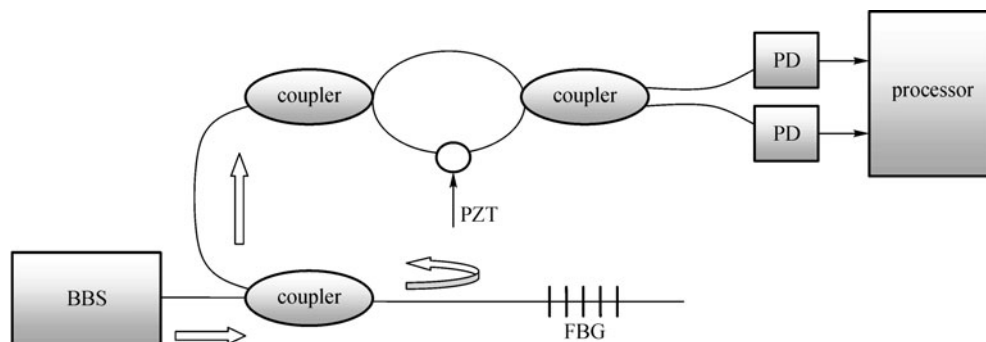

Fig. 10 Schematic diagram of interrogation system based on nonequilibrium M-Z interferometer

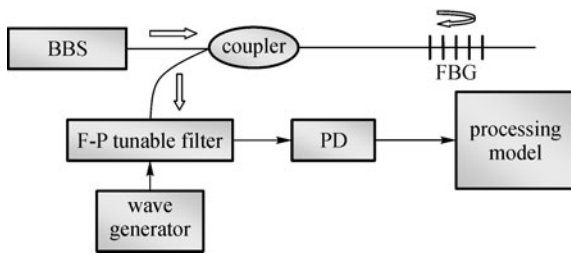

Fig. 11 Schematic diagram of F-P tunable filter interrogation system

to their advantages, such as wide wavelength tuning bandwidth (> 100 nm) and fast tuning speed (< 10 ms), and variable attenuation via simple electronic control [35]. Like F-P filter, the correlated spectrum of AOTF and FBG is recorded by detectors and computed through a peak search algorithm to extract the wavelength shift. By applying multiple radio frequency (RF) signal onto AOTF, multiwavelength parallel processing of could be easily achieved (Fig. 12). To reduce the coupling loss and to ensure stability, all-fiber AOTF is the preferred one. However, mature all-fiber AOTF product is too expensive for demodulation of small-scale FBG arrays.

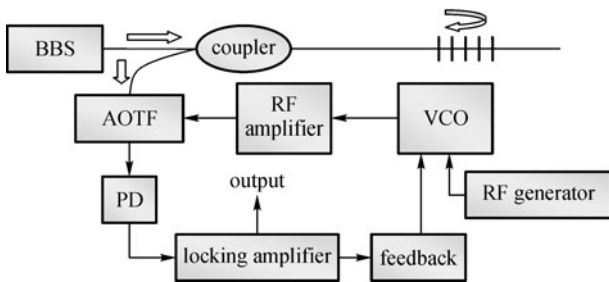

Fig. 12 Schematic diagram of AOTF-based interrogation system (VCO: voltage controlled oscillator)

5.3 Tunable-light-source-based interrogation

Interrogation based on tunable light source, especially tunable lasers, was proposed to acquire higher resolution, signal-to-noise ratio (SNR), and chirping information. This interrogation approach employs continuously tunable laser to scan the reflection wavelength of FBG. As tunable laser scans the reflection wavelength of the sensing FBG, interrogation can be realized by monitoring the maximum peak intensity of the transmission or reflection spectrum. As it is well known, laser has many unique advantages, such as high intensity and narrow band, which yields higher resolution and SNR. A wavelength resolution of ~ 2.3 pm corresponding to 0.2°C was obtained in Ref. [36]. However, it still has a few shortcomings, such as narrow tunable bandwidth and instability, which seriously limit its

applications. It is believed that with the development of continuously tunable laser, this method will be widely employed for FBG sensor interrogation.

Other tunable-source-interrogation-based methods like mode-locked method and interrogation based on ring cavity tunable fiber laser were reported in Refs. [37,38].

5.4 Interrogation using tilted fiber gratings

The operation principle of this method is based on the measurement of the near-field leaky radiation of the titled fiber grating [39]. When light reflected by FBG illuminates an in-fiber tilted grating, leaky radiation is detected by a photo-detector linear array. By analyzing the characteristics of this radiation, the reflection wavelength of FBG could be obtained. This method has a wide interrogation range; it is able to simultaneously extract information from multiplexed gratings; and its wavelength resolution reaches more than 3.7 pm. However, this interrogation approach involves complex spectrum analysis, which brings difficulties for engineering applications (Fig. 13).

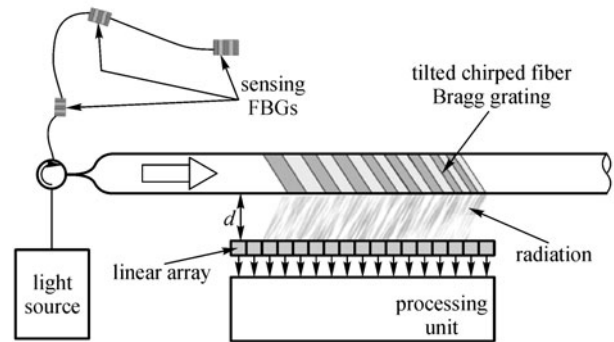

Fig. 13 Schematic diagram of interrogation system based on tilted fiber grating proposed in Ref. [39]

5.5 Wavelength-to-time mapping interrogation

The key significance of this technique is that the wavelength-to-time mapping technique is utilized to convert the spectrum of an FBG or FBG array from wavelength domain to time domain [40,41]. Wavelength-to-time mapping is implemented in real time, and a good SNR is guaranteed by using the mode-locked femtosecond pulsed laser. This method can operate at an ultrafast speed, which is determined by the frequency of the femtosecond pulsed laser, and possesses a large interrogation range referenced to the spectral range of ultrafast pulse. A dynamic range as large as 20 nm and a sensing accuracy up to $0.87 \mu\text{e}$ were obtained for a sampling speed of 48.6 MHz in Ref. [42]. The newly developed Fourier domain mode-locked lasers (FDML) wavelength swept laser shows a superior performance of a high scan rate of 31.3 kHz and a broad scan range of over 70 nm. The schematic diagram of this system is shown in Fig. 14.

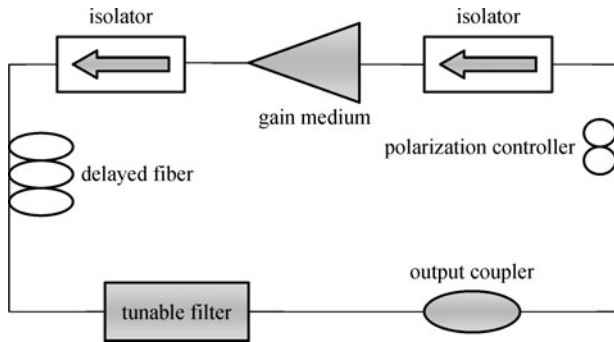

Fig. 14 Schematic diagram of interrogation system based on FDML wavelength swept laser

5.6 Other interrogation methods

Besides the above mentioned methods, there are many other interrogation solutions, such as edge filtering method, beat frequency interrogation [43], interrogation based on optical rotatory dispersion effect, arrayed waveguide grating (AWG) interrogation method [44], active time-domain interrogation, orthogonal sampling interrogation based on M-Z interferometer [45], etc.

There are still many issues to be solved for FBG wavelength interrogation for engineering applications. Relatively high cost of optical devices calls for sensor multiplexing and simultaneous demodulation system for different wavelengths. Single interrogation method can hardly implement the dynamic and static measurement at the same time. High-speed and wide-range interrogation often requires rather high system cost and complex system configuration, which is currently limited to a laboratory level. As a whole, good stability, high accuracy, compactness, and reasonable cost of the interrogation systems are a prerequisite conditions for large-scale commercial applications of FBG sensors, and there is still a long way ahead.

6 Conclusion

FBG sensor technology has been and will be one of the most practical technologies for a long period. Owing to its inherent advantages, it will inevitably substitute the conventional sensing technology in the near future. However, the current status of FBG sensor technology are still far from meeting the engineering demands, and there are still many issues to be resolved, such as reducing system cost, exploration of new sensing mechanism, and attempt of smart optical materials and fiber optic devices.

Acknowledgements This work was jointly supported by the National Key Natural Science Foundation of China (Grant No. 60736039), the National Natural Science Foundation of China (Grant Nos. 10904075, 11004110, and 50802044), the Fundamental Research Funds for the Central Universities, and the National Key Basic Research and Development Program of China (Grant No. 2010CB327605).

References

1. Lee B. Review of the present status of optical fiber sensors. *Optical Fiber Technology*, 2003, 9(2): 57–79
2. Rao Y J. In-fibre Bragg grating sensor. *Measurement Science & Technology*, 1997, 8(4): 355–375
3. Othonos A. Fiber Bragg gratings. *Review of Scientific Instruments*, 1997, 68(12): 4309–4341
4. Hill K O, Meltz G. Fiber Bragg grating technology fundamentals and overview. *Journal of Lightwave Technology*, 1997, 15(8): 1263–1276
5. Rao Y J. Fiber Bragg grating sensors: principles and applications. In: Grattan K T V, Meggitt B T, eds. *Optical Fiber Sensor Technology*, 1998, 2: 355–389
6. Shu X W, Liu Y, Zhao D H, Gwandu B, Floreani F, Zhang L, Bennion I. Dependence of temperature and strain coefficients on fiber grating type and its application to simultaneous temperature and strain measurement. *Optics Letters*, 2002, 27(9): 701–703
7. Kersey A D, Davis M A, Patrick H J, LeBlanc M, Koo K P, Askins C G, Putnam M A, Friebele E J. Fiber grating sensors. *Journal of Lightwave Technology*, 1997, 15(8): 1442–1463
8. Xu M G, Archambault J L, Reekie L, Dakin J P. Thermally-compensated bending gauge using surface-mounted fiber gratings. *International Journal of Optoelectron*, 1994, 3(9): 281–283
9. Dong X Y, Liu Y Q, Liu Z G, Dong X Y. Simultaneous displacement and temperature measurement with cantilever-based fiber Bragg grating sensor. *Optics Communications*, 2001, 192(3–6): 213–217
10. Patrick H J, Williams G M, Kersey A D, Pedrazzani J R, Vengsarkar A M. Hybrid fiber Bragg grating/long period fiber grating sensor for strain/temperature discrimination. *IEEE Photonics Technology Letters*, 1996, 8(9): 1223–1225
11. Guan B O, Tam H Y, Tao X M, Dong X Y. Simultaneous strain and temperature measurement using a superstructure fiber Bragg grating. *IEEE Photonics Technology Letters*, 2000, 12(6): 675–677
12. Dong X Y, Yang X F, Zhao C L, Ding L, Shum P, Ngo N Q. A novel temperature-insensitive fiber Bragg grating sensor. *Smart Materials and Structures*, 2005, 14(2): N7–10
13. Song M, Lee B, Lee S B, Choi S S. Interferometric temperature-insensitive strain measurement with different-diameter fiber Bragg gratings. *Optics Letters*, 1997, 22(11): 790–792
14. Frazao O, Carvalho J P, Ferreira L A, Marques L, Araujo F M, Santos J L. Discrimination of strain and temperature using Bragg grating in microstructured and standard optical fibers. *Measurement Science and Technology*, 2005, 16(10): 2109–2113
15. Chuang K C, Ma C C. Pointwise fiber Bragg grating displacement sensor system for dynamic measurements. *Applied Optics*, 2008, 47(20): 3561–3567
16. Niewczas P, Dziuda L, Fusie G, McDonald J R. Temperature compensation for a piezoelectric fiber-optic voltage sensor. In: *Proceedings of IMTC 2006 – Instrumentation and Measurement Technology Conference*. 2006, 1994–1998
17. Fusick G, Niewczas P, Dziuda L, McDonald J R. Hysteresis compensation for a piezoelectric fiber-optic voltage sensor. *Optical Engineering*, 2005, 44(11): 345–348

18. Liu B, Niu W, Yang Y, Luo J, Cao Y, Kai G, Zhang W, Dong X. A novel fiber Bragg grating accelerometer. *Chinese Journal of Scientific Instrument*, 2006, 27(1): 42–44 (in Chinese)
19. Bao H, Dong X, Shao L Y, Zhao C L, Chan C C, Shum P. Temperature-insensitive 2-D pendulum clinometer using two fiber Bragg gratings. *IEEE Photonics Technology Letters*, 2010, 22(12): 863–865
20. Li H M, Gao H W, Liu B, Luo J H, Kai G Y, Yuan S Z, Dong X Y. A novel fiber Bragg grating flowmeter. *Chinese Journal of Sensors and Actuators*, 2006, 19(4): 1195–1197 (in Chinese)
21. Sato H, Watanabe K L. Experimental study on the use of a vortex whistle as a flowmeter. *Instrumentation and Measurement*, 2000, 49(1): 200–205
22. Lee K O, Chiang K S, Chen Z H. Temperature-insensitive fiber-Bragg-grating-based vibration sensor. *Optical Engineering*, 2001, 40(11): 2582–2585
23. Takahashi N, Yoshimura K, Takahashi S. Detection of ultrasonic mechanical vibration of a solid using fiber Bragg grating. *Japanese Journal of Applied Physics*, 2000, 39: 3134–3138
24. Zhang W G, Liu Y G, Kai G Y, Zhao Q D, Yuan S Z, Dong X Y. A novel independent tuning technology of center wavelength and bandwidth of fiber Bragg grating. *Optics Communications*, 2003, 216(4–6): 343–350
25. Gwandu B A L, Zhang L, Chisholm K, Shu X, Bennion I. Compact FBG array structure for high spatial resolution distributed strain sensing. *Measurement Science & Technology*, 2001, 12(7): 918–921
26. Vohra S T, Todd M D, Johnson G A, Chang C C, Danver B A. Fiber Bragg grating sensor system for civil structure monitoring: applications and field tests. *Proceedings of SPIE*, 1999, 3746: 32–37
27. Henderson P J, Webb D J, Jackson D A, Zhang L, Bennion I. Highly-multiplexed grating-sensors for temperature-referenced quasi-static measurements of strain in concrete bridges. *Proceedings of SPIE*, 1999, 3746: 320–323
28. Weis R S, Kersey A D, Berkoff T A. A four-element fiber grating sensor array with phase-sensitive detection. *IEEE Photonics Technology Letters*, 1994, 6(12): 1469–1472
29. *Optical Fiber Sensor Technology*. Vol. 2. London: Chapman & Hall, 1998, 355–389
30. Andreas O, Kyriacos K. *Fiber Bragg Gratings: Fundamentals and Applications in Telecommunications and Sensing*. Boston, MA: Artech House, 1999
31. Ashoori R, Gebrmichal Y M, Xiao S, Kemp J, Grattan K T V, Palmer A W. Time domain multiplexing for Bragg grating strain measurement sensor network. *Proceedings of SPIE*, 1998, 3746: 308–311
32. Yao Y, Yi B S, Xiao J S. Research progress in wavelength demodulation technology of fiber Bragg grating sensors. *Optical Communication Technology*, 2007, 31(11): 41–45 (in Chinese)
33. Koo K P, Kersey A D. Bragg grating based laser sensor system with interferometric interrogation and wavelength division multiplexing. *Journal of Lightwave Technology*, 1995, 13(7): 1243–1249
34. Kersey A D, Berkoff T A, Morey W W. Multiplexed fiber Bragg grating strain-sensor system with a fiber Fabry-Perot wavelength filter. *Optics Letters*, 1993, 18(16): 1370–1372
35. Kim H S, Yun S H, Kwang I K, Kim B Y. All-fiber acousto-optic tunable notch filter with electronically controllable spectral profile. *Optics Letters*, 1997, 22(19): 1476–1478
36. Ball G A, Morey W W, Cheo P K. Fiber laser source/analyzer for Bragg grating sensor array interrogation. *Journal of Lightwave Technology*, 1994, 12(4): 700–703
37. Chen G, Xiao H, Huang Y, Zhang Y, Zhou Z. Simultaneous strain and temperature measurement using long-period fiber grating sensors. *Proceedings of SPIE*, 2010, 7649: 343–346
38. Kersey A D, Morey W W. Multiplexed Bragg grating fibre-laser strain-sensor system with mode-locked interrogation. *Electronics Letters*, 1993, 29(1): 112–114
39. Yun S H, Richardson D J, Kim B Y. Interrogation of fiber grating sensor arrays with a wavelength-swept fiber laser. *Optics Letters*, 1998, 23(11): 843–845
40. Jáuregui C, Quintela A, López-Higuera J M. Interrogation unit for fiber Bragg grating sensors that uses a slanted fiber grating. *Optics Letters*, 2004, 29(7): 676–678
41. Xia H Y, Wang C, Sebastien B, Yao J P. Ultrafast and precise interrogation of fiber Bragg grating sensor based on wavelength-to-time mapping incorporating higher order dispersion. *Journal of Lightwave Technology*, 2010, 28(3): 224–261
42. Jung E J, Kim C S, Jeong M Y, Kim M K, Jeon M Y, Jung W, Chen Z P. Characterization of FBG sensor interrogation based on a FDML wavelength swept laser. *Optics Express*, 2008, 16(21): 16552–16560
43. Gagliardi G, Salza M, Ferraro P, De Natale P. Fiber Bragg-grating strain sensor interrogation using laser radio-frequency modulation. *Optics Express*, 2005, 13(7): 2377–2384
44. Sano Y, Yoshino T. Fast optical wavelength interrogator employing arrayed waveguide grating for distributed fiber Bragg grating sensors. *Journal of Lightwave Technology*, 2003, 21(1): 132–139
45. Song M, Yin S, Ruffin P B. Fiber Bragg grating strain sensor demodulation with quadrature sampling of a mach-zehnder interferometer. *Applied Optics*, 2000, 39(7): 1106–1111