

Temperature sensing capacity of fiber Bragg grating at liquid nitrogen temperature

Guoli CAI (✉)¹, Wei JIAN²

¹ State Intellectual Property Office of the People's Republic of China, Beijing 100088, China
² Lightwave Technology Institute, Beijing Jiaotong University, Beijing 100044, China

© Higher Education Press and Springer-Verlag 2008

Abstract According to the temperature sensing model of the fiber Bragg grating (FBG), a theoretical method of temperature sensing capacity of FBG is proposed. Based on the temperature sensing model of FBG, a temperature sensing experiment was completed at liquid nitrogen temperature (-196°C). The theoretical and experimental results were compared and analyzed, which show that at liquid nitrogen temperature or in a large-scope temperature sensing, the relationship between thermal variation ΔT and relative shift of reflected center wavelength $\Delta\lambda_B/\lambda_B$ of FBG is nonlinear and conic multinomial.

Keywords fiber Bragg grating (FBG), optical fiber sensing, temperature sensing, liquid nitrogen temperature

1 Introduction

The fiber Bragg grating (FBG) is a fiber passive apparatus, which was rapidly developed and widely applied in recent years. Measuring the temperature change is the most important and direct application of an FBG sensor. Lots of researches had been carried out in this regard, but most of them were involved in the normal temperature zone, while few were covered below zero. Some relevant researches considered the relationship between thermal variation ΔT and reflected center wavelength λ_B as linear, but it is not suitable for wavelength variation at low temperatures or in the large-scope temperature sensing.

According to the temperature sensing model of FBG, the theoretical research was carried out, which focused on the relationship between the thermal variation and the relative shift of the reflected center wavelength. The relationship was put forward at liquid nitrogen temperature

(-196°C) based on the experiment. The theoretical and experimental results were compared and analyzed, which show that at liquid nitrogen temperature or in a large-scope temperature sensing, the relationship between thermal variation ΔT and relative shift of reflected center wavelength $\Delta\lambda_B/\lambda_B$ of FBG is nonlinear and conic multinomial. The result is helpful on both the theoretical analysis and application research on the mechanism of FBG temperature sensing.

2 Theory of FBG temperature sensing

FBG is an apparatus whose refractive index is lengthways cycled distribution, and its Bragg equation is

$$\lambda_B(T) = 2n_{\text{eff}}\Lambda. \quad (1)$$

When the environmental temperature T changes, without consideration of the strain affection, the effective refractive index n_{eff} and the FBG spatial cycle Λ would change by the calorescence effect and the thermal dilatant effect, which is due to the shift of the Bragg reflected center wavelength λ_B . If the original environmental temperature is T_0 , $\lambda_B(T)$ is expanded by Thaler, and kept quantic item, then

$$\lambda_B(T) = \lambda_B(T_0) + \frac{d\lambda_B(T)}{dT}\Delta T + \frac{1}{2}\frac{d^2\lambda_B(T)}{dT^2}\Delta T^2, \quad (2)$$

where $\Delta T = T - T_0$.

By Eqs. (1) and (2), we can get

$$\begin{aligned} \frac{\Delta\lambda_B}{\lambda_B} &= \frac{\lambda_B(T) - \lambda_B(T_0)}{\lambda_B(T)} \\ &= \frac{1}{\lambda_B} \frac{d\lambda_B}{dT} \Delta T + \frac{1}{2} \frac{1}{\lambda_B} \frac{d^2\lambda_B}{dT^2} \Delta T^2 = \eta \Delta T, \end{aligned} \quad (3)$$

where η represents the thermal sensitivity coefficient,

Translated from *Study on Optical Communications*, 2006, (6): 56-57
[译自: 光通信研究]

E-mail: gl_cai23@yahoo.com.cn

$$\eta = \frac{1}{\lambda_B} \frac{d\lambda_B}{dT} + \frac{1}{2} \frac{1}{\lambda_B} \frac{d^2\lambda_B}{dT^2} \Delta T. \quad (4)$$

Taking the natural logarithm on Eq. (1) and taking the derivative on T , we can get the following equation:

$$\frac{1}{\lambda_B} \frac{d\lambda_B}{dT} = \frac{1}{n_{\text{eff}}} \frac{dn_{\text{eff}}}{dT} + \frac{1}{\Lambda} \frac{d\Lambda}{dT}, \quad (5)$$

where $\frac{1}{\lambda_B} \frac{d\lambda_B}{dT}$ is the calorescence coefficient of FBG and indicated as ε , and $\frac{1}{\Lambda} \frac{d\Lambda}{dT}$ is the thermal dilatant coefficient of FBG and indicated as α . Therefore, Eq. (5) can be described as

$$\frac{1}{\lambda_B} \frac{d\lambda_B}{dT} = \varepsilon + \alpha. \quad (6)$$

By Eq. (6), we can get

$$\frac{1}{\lambda_B} \frac{d^2\lambda_B}{dT^2} = \left[\frac{d\varepsilon}{dT} + \frac{d\alpha}{dT} + (\varepsilon + \alpha)^2 \right]. \quad (7)$$

By Eqs. (5), (6) and (7), we can get

$$\eta = (\varepsilon + \alpha) + \frac{1}{2} \left[\frac{d\varepsilon}{dT} + \frac{d\alpha}{dT} + (\varepsilon + \alpha)^2 \right] \Delta T. \quad (8)$$

The thermal dilatants' coefficient and the calorescence coefficient of germanium-doped silicon fiber are $\alpha \approx 0.5 \times 10^{-6}/^\circ\text{C}$ [1] and $\varepsilon \approx 8.3 \times 10^{-6}/^\circ\text{C}$ [2,3], respectively. Because the mechanical parameter changes with temperature, there is a reliable relationship between the thermal dilatant coefficient α , the calorescence coefficient ε and temperature is not constant. Therefore, the FBG thermal sensitivity coefficient η is not constant.

3 Experimental results and analysis

Many researches indicated that the accurate measurement temperature with FBG was not meant to measure the thermal sensitivity coefficient with fiber mechanical parameter. The accurate measurement temperature should be based on the experiments because the original mechanical parameter will change after the silicon through fiber forming and input fiber grating. The laboratory quadratic curve fitting equation of Refs. [4] and [5] is

$$\frac{\Delta\lambda_B}{\lambda_B} = (6.045 \times 10^{-6} + 10^{-8} \Delta T) \Delta T. \quad (9)$$

The measurement temperature zone of this curve is 20°C – 260°C , which does not cover the temperature response of the reflected center wavelength of the FBG in the low temperature zone. The temperature response of the reflected center wavelength of FBG at liquid nitrogen

temperature (-196°C) was measured. The experimental equipment is shown in Fig. 1. The light from the erbium-doped fiber amplifier (EDFA, produced by TAIKE) makes the incidence to the FBG in the liquid nitrogen through the ring, and the reflected light by FBG goes into the optical spectrum analyzers (OSA, produced by ANDO with AQ6319, and its resolution is 0.001 nm) through the ring. The FBG was produced by Lightwave Technology Institute, Beijing Jiaotong University, which used ultraviolet radiation and induced it to the germanium-doped single-mode fiber at the ultraviolet zone through the technology of phase masks.

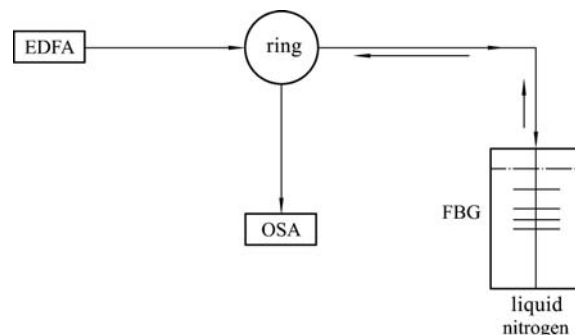

Fig. 1 Experimental equipment of thermal sensing

The FBG reflected wavelength λ_B is 1559.650 nm. Figure 2 shows the FBG reflected spectrogram at room temperature (23°C), and Fig. 3 shows the FBG reflected spectrogram at liquid nitrogen temperature (-196°C). From room temperature to liquid nitrogen temperature, the total shift $\Delta\lambda_{B0}$ of the reflected center wavelength λ_B is 1.398 nm. The cycle experiment of liquid nitrogen temperature to room temperature, to liquid nitrogen temperature was implemented 4 times. The experimental data is listed in the Table 1. The shift of λ_B is about 1.4 nm, which indicates that the thermal variation is a reversible process to FBG.

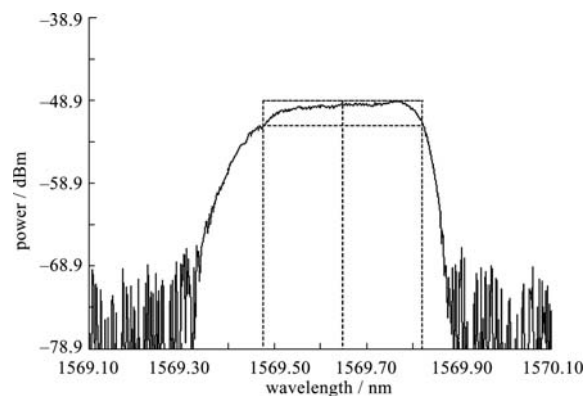

Fig. 2 FBG reflected spectrogram at room temperature (23°C)

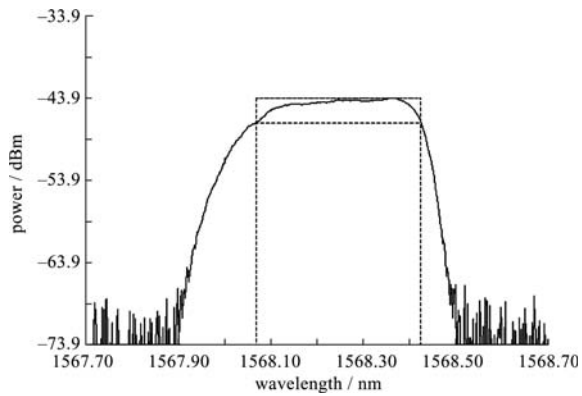

Fig. 3 FBG reflected spectrogram at the temperature point of liquid nitrogen state (-196°C)

Table 1 Measurement data of temperature sensing (nm)

λ_B (23°C)	λ_B (-196°C)	$\Delta\lambda_{B0}$
1569.650	1568.251	1.399
1569.650	1568.249	1.401
1569.650	1568.247	1.403
1569.650	1568.252	1.398

In terms of Eq. (9), the shift $\Delta\lambda_B$ of FBG at liquid nitrogen temperature is 1.325 nm, inoculated with the shift of the wavelength in the experiment. The deviation may be caused by some factors such as the difference of FBG, and the reflected center wavelength, etc. The experimental results indicate that FBG can realize the temperature sensing at liquid nitrogen temperature, there is no aberrance in

the FBG reflected spectrogram, and the shift of the wavelength is quadric with temperature.

4 Conclusions

We studied the characteristics of FBG at low temperature, measured the relative shift of the reflected center wavelength at liquid nitrogen temperature, and obtain the following conclusions: 1) FBG can achieve temperature sensing at liquid nitrogen temperature, and there is no aberrance in the FBG reflected spectrogram. 2) The relative shift of reflected wavelength is quadric with the temperature variation.

References

1. Malitson I H. Interspecimen comparison of the refractive index of fused silica. *Journal of the Optical Society of America*, 1965, 55(10): 1205–1209
2. Wemple S H. Refractive-index behavior of amorphous semiconductors and glasses. *Physical Review B*, 1973, 7(8): 3767–3777
3. Takahashi S, Shibata S. Thermal variation of attenuation for optical fibers. *Journal of Non-Crystalline Solids*, 1979, 30(3): 359–370
4. Jia Z A, Qiao X G, Li M, et al. Nonlinear phenomena of fiber Bragg grating temperature sensing. *Acta Photonica Sinica*, 2003, 32(7): 844–847 (in Chinese)
5. Qiao X G, Jia Z A, Fu H W, et al. Theory and experiment about in-fiber Bragg grating temperature sensing. *Acta Physica Sinica*, 2004, 53(2): 494–497 (in Chinese)