

Supaporn LONAPALAWONG, Changsheng CHEN, Can WANG, Wei CHEN, 2022. Interpreting the vulnerability of power systems in cascading failures using multi-graph convolutional networks. *Frontiers of Information Technology & Electronic Engineering*, 23(12):1848-1861. <https://doi.org/10.1631/FITEE.2200035>

# Interpreting the vulnerability of power systems in cascading failures using multi-graph convolutional networks

**Key words:** Power systems; Vulnerability; Cascading failures; Multi-graph convolutional networks; Weighted line graph

Corresponding author: Wei CHEN

E-mail: [chenwei@cad.zju.edu.cn](mailto:chenwei@cad.zju.edu.cn)

 ORCID: <https://orcid.org/0000-0002-9853-8049>

# Motivation

---

1. Analyzing the vulnerability of power systems in cascading failures is generally regarded as a challenging problem.
2. The graph convolutional network (GCN) is a deep learning based method that operates in the graph domain, which is designed to work directly on graphs and leverage structural information.
3. Existing studies can extract some critical rules, but they fail to capture the complex subtleties under different operational conditions.
4. GCNs are seen as “black-box” models; thus, it is difficult to explain how and why the system reaches a particular outcome.

# Main idea

1. Based on the branch information, a line graph topology can better understand the information from the branch relationship perspective. We consider the spatial information that describes the informative edge by adjusting weight importance.
2. Compared with the existing deep learning models, multi-graph convolutional networks learn the graph features while considering the power system topology information with a variable graph structure and size.
3. The layer-wise relevance propagation (LRP) model identifies the contributing factors that may have caused the cascading failures and manage the power system to mitigate the damage.

# Method

## 1. Data generation

The ORNL-PSERC-Alaska (OPA) model simulates the features of a cascading failure in each sample. Every sample includes five elements, the topological connection, branch flow, busload, protection relay, and component outage, as part of the GCN. The target class is a component outage.

# Method (Cont'd)

## 2. Weighted line graph transformation

Convert the graph topology to branch topology and identify the concept of a weighted line graph to capture the edge importance based on the graph structure. Then, calculate the impedance value to quantify the spatial correlation of the power system.

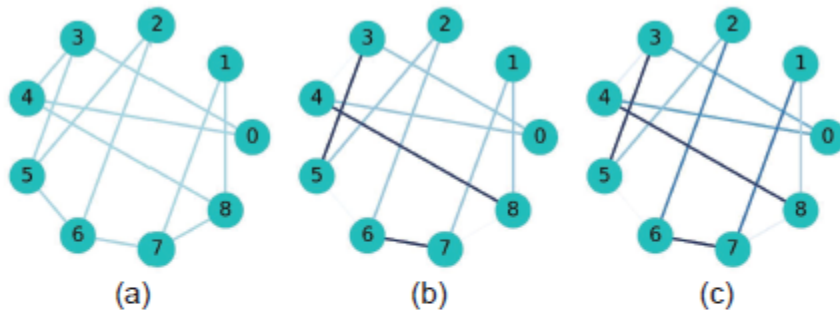

Fig. 4 IEEE 9-bus system with different weighted line graphs: (a) original line graph; (b) weighted line graph that captures the structural degree; (c) power-weighted line graph that captures both structural degree and electrical distance. An edge with a larger weight is displayed darker. References to color refer to the online version of this figure

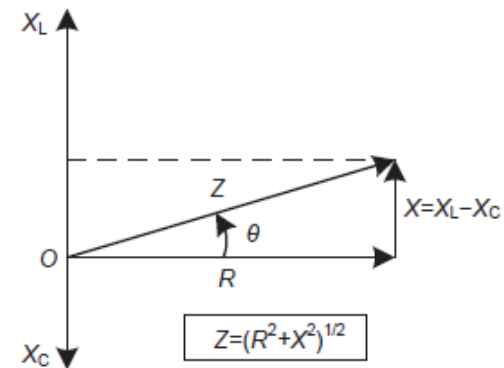
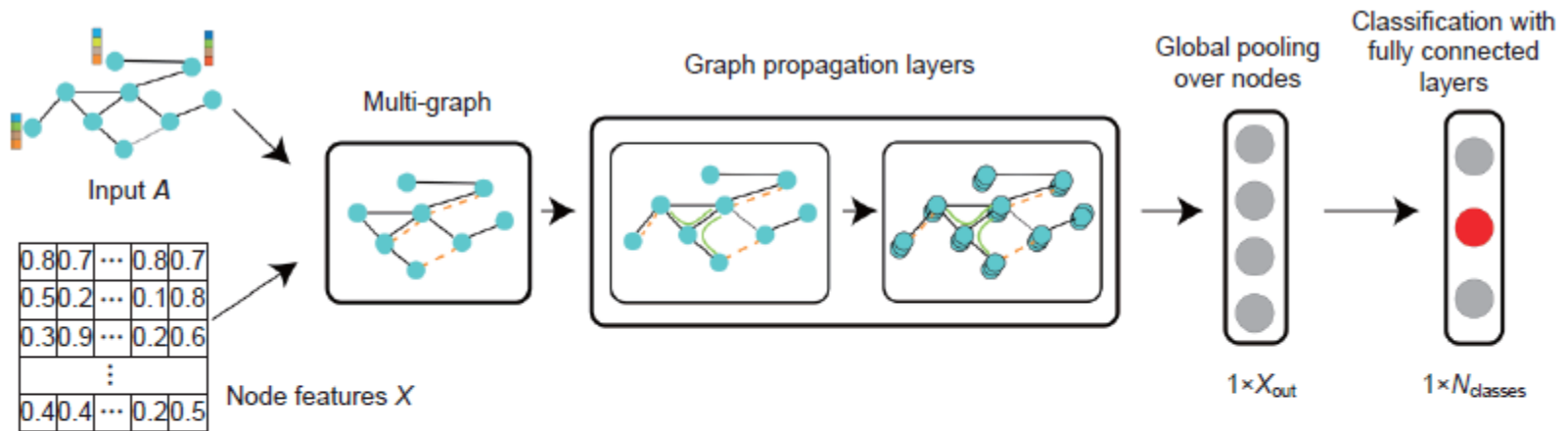

Fig. 3 Identifying impedance as the electrical distance: impedance ( $Z$ ) is a measure of how much the circuit impedes the charge flow. Impedance can be split into two parts: resistance  $R$  (the part that is constant, regardless of frequency) and reactance  $X$  (the part that varies with frequency due to capacitance and inductance)

# Method (Cont'd)

3. To study the multigraph, we consider abstract learning edges jointly with a GCN



**Fig. 6** Pipeline for graph classification. In our model, the network is sent through the  $l^{th}$  convolutional layer, which produces a graph with identical nodes and edges. As the receptive field grows larger, the node features of our line graph become increasingly global, but the edges remain unchanged. As a consequence, each node in the graph includes information about its neighbors and the complete graph after numerous graph convolutional layers. We summarize the data acquired by each node by pooling it over nodes. To conduct classification, fully connected layers use global pooling. Connections learned as outlined in Eq. (9) are indicated by a dashed orange line. References to color refer to the online version of this figure

# Method (Cont'd)

4. To understand the model prediction, the LRP algorithm was proposed for explaining how input data support the prediction in the trained model.

# Major results

## Accuracy result

Table 2 Accuracy of different models in the IEEE test system

Topology	Accuracy (%)					
	IEEE 14			IEEE 30		
	Original ADJ	W-ADJ	PW-ADJ	Original ADJ	W-ADJ	PW-ADJ
GCN	64.20 ( $\pm 1.1$ )	75.58 ( $\pm 1.0$ )	75.98 ( $\pm 1.2$ )	59.57 ( $\pm 1.7$ )	63.31 ( $\pm 1.3$ )	62.71 ( $\pm 1.5$ )
ChebConv	82.23 ( $\pm 1.2$ )	81.49 ( $\pm 0.5$ )	81.76 ( $\pm 0.5$ )	68.01 ( $\pm 1.3$ )	67.46 ( $\pm 1.3$ )	67.38 ( $\pm 0.9$ )
GCN ( $K=4$ )	80.31 ( $\pm 1.6$ )	79.81 ( $\pm 1.5$ )	80.81 ( $\pm 1.1$ )	67.93 ( $\pm 1.3$ )	68.57 ( $\pm 2.0$ )	68.32 ( $\pm 1.1$ )
MGCN	73.21 ( $\pm 7.9$ )	79.76 ( $\pm 2.5$ )	79.59 ( $\pm 2.1$ )	64.63 ( $\pm 1.5$ )	64.74 ( $\pm 1.2$ )	65.15 ( $\pm 1.0$ )
MGCN-ChebConv	84.06 ( $\pm 3.0$ )	<b>84.12 (<math>\pm 1.9</math>)</b>	82.51 ( $\pm 1.1$ )	<b>69.10 (<math>\pm 1.3</math>)</b>	68.81 ( $\pm 1.5$ )	68.41 ( $\pm 0.9$ )
MGCN ( $K=4$ )	81.16 ( $\pm 0.8$ )	80.77 ( $\pm 5.0$ )	81.70 ( $\pm 1.3$ )	68.67 ( $\pm 1.0$ )	68.95 ( $\pm 1.0$ )	68.50 ( $\pm 1.1$ )
UNET	66.90 ( $\pm 2.0$ )	71.43 ( $\pm 2.2$ )	69.56 ( $\pm 2.5$ )	56.35 ( $\pm 1.5$ )	57.79 ( $\pm 2.7$ )	56.83 ( $\pm 3.7$ )

Topology	Accuracy (%)					
	IEEE 39			IEEE 118		
	Original ADJ	W-ADJ	PW-ADJ	Original ADJ	W-ADJ	PW-ADJ
GCN	80.13 ( $\pm 2.0$ )	84.42 ( $\pm 3.5$ )	91.08 ( $\pm 1.1$ )	83.65 ( $\pm 1.8$ )	84.53 ( $\pm 3.9$ )	89.58 ( $\pm 1.0$ )
ChebConv	86.28 ( $\pm 1.1$ )	86.88 ( $\pm 1.7$ )	94.63 ( $\pm 1.5$ )	91.14 ( $\pm 1.2$ )	90.91 ( $\pm 0.9$ )	92.49 ( $\pm 0.6$ )
GCN ( $K=4$ )	93.49 ( $\pm 0.7$ )	93.44 ( $\pm 1.3$ )	94.09 ( $\pm 1.2$ )	91.69 ( $\pm 1.2$ )	92.40 ( $\pm 0.8$ )	94.01 ( $\pm 0.8$ )
MGCN	90.71 ( $\pm 4.7$ )	89.01 ( $\pm 6.4$ )	95.44 ( $\pm 2.4$ )	89.64 ( $\pm 0.8$ )	88.14 ( $\pm 1.4$ )	88.90 ( $\pm 1.1$ )
MGCN-ChebConv	95.84 ( $\pm 0.8$ )	95.26 ( $\pm 1.0$ )	96.61 ( $\pm 0.7$ )	93.33 ( $\pm 0.7$ )	92.95 ( $\pm 0.7$ )	93.17 ( $\pm 1.0$ )
MGCN ( $K=4$ )	95.04 ( $\pm 3.3$ )	95.90 ( $\pm 2.5$ )	<b>97.03 (<math>\pm 1.1</math>)</b>	93.89 ( $\pm 0.3$ )	94.07 ( $\pm 0.6$ )	<b>94.21 (<math>\pm 0.6</math>)</b>
UNET	80.34 ( $\pm 3.2$ )	82.24 ( $\pm 3.9$ )	86.00 ( $\pm 4.3$ )	78.59 ( $\pm 2.3$ )	78.41 ( $\pm 6.4$ )	82.77 ( $\pm 5.8$ )

The best results are in bold.  $K$  is a filter scale in graph convolution. ADJ: adjacency matrix. W-ADJ and PW-ADJ denote weighted ADJ and power-weighted ADJ, respectively. The GCN and UNET models use only a single edge. The other models use both edges, where the second edge is learned based on node features

# Major results (Cont'd)

Interpreting result of IEEE 39 dataset using MGCN model.

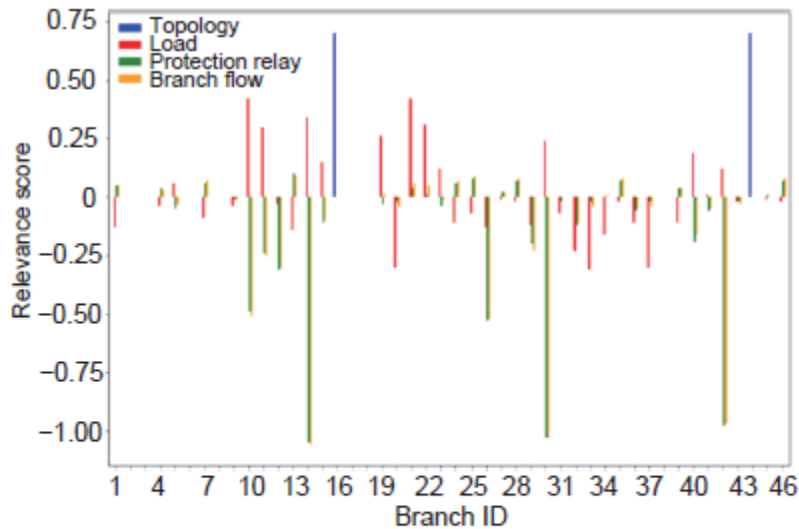

Fig. 8 Relevance score for each input of the MGCN model that is triggered on the initial failures of L16 and L44 (IEEE 39). References to color refer to the online version of this figure

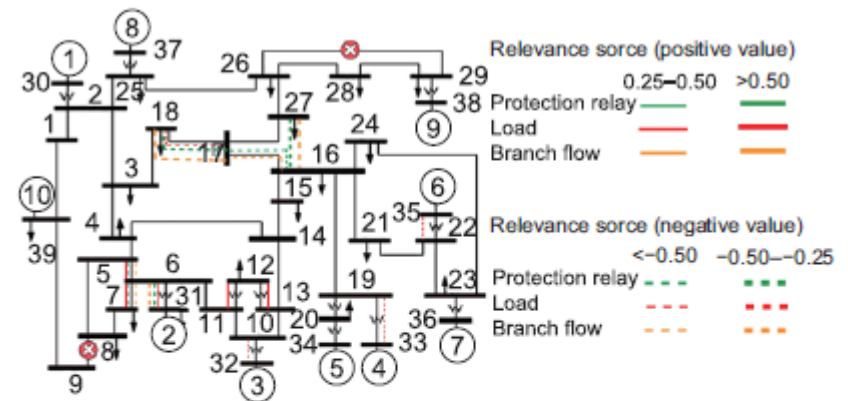

Fig. 9 Topological graph representing a part of IEEE 39 after L16 and L44 are triggered. The target class is predicted as a medium-level component outage. References to color refer to the online version of this figure

# Major results (Cont'd)

Interpreting result of IEEE 118 dataset using MGCN model.

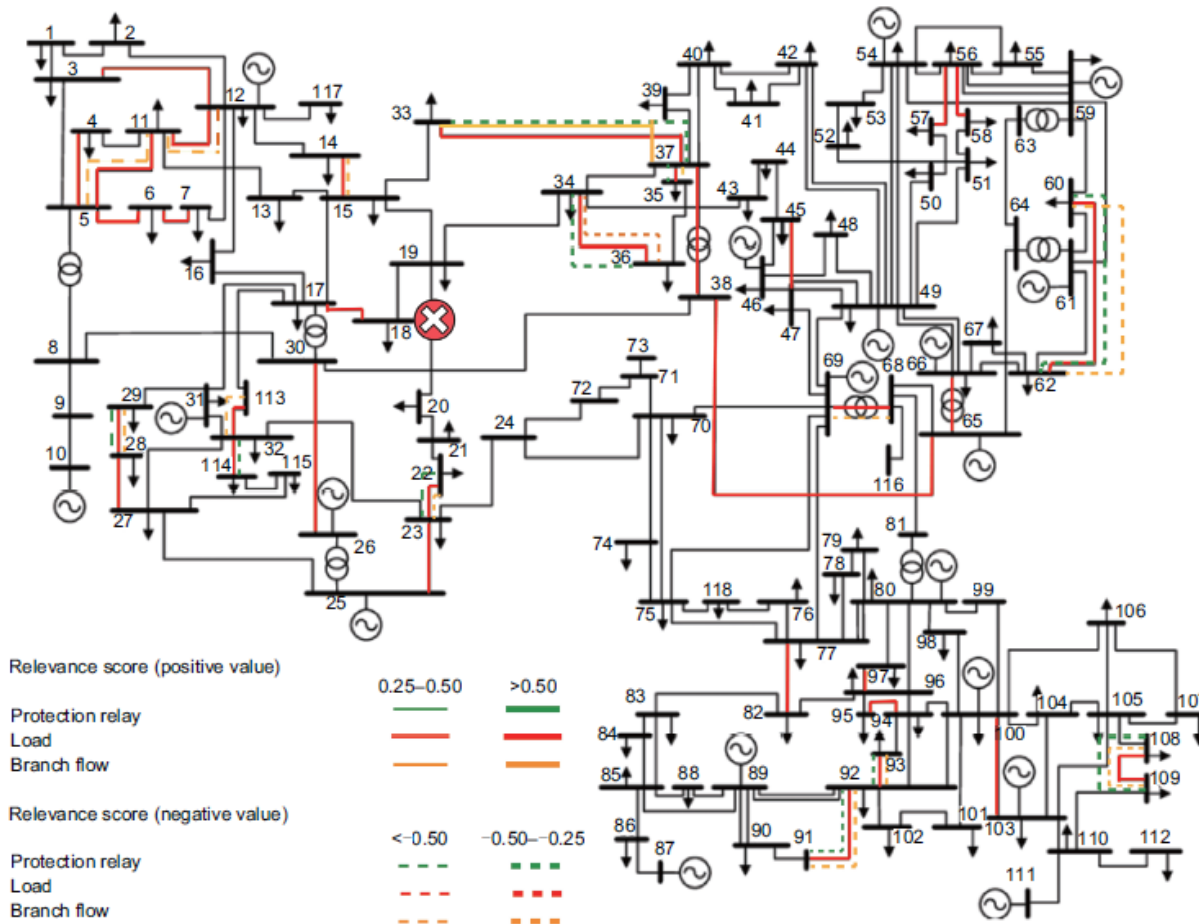

Fig. 11 Topological graph representing a part of IEEE 118 after L31 is triggered. The target class is predicted as a low-level component outage. References to color refer to the online version of this figure

# Conclusions

1. For vulnerability analysis of power systems in cascading failures, the multi-graph convolutional network model has been proposed for classifying the power system's vulnerability level.
2. Power weight topology improved the prediction accuracy based on the MGCN model.
3. The prediction results of the MGCN model are interpretable, enabling the user to check the logic of the model and uncover the factors that caused the cascading failures.



Supaporn LONAPALAWONG is currently a PhD student in the College of Computer Science and Technology at Zhejiang University. Her research interests include data mining and visual analytics.



Dr. Wei CHEN is a professor in State Key Lab of CAD & CG at Zhejiang University, China. From June 2000 to June 2002, he was a joint PhD student in Fraunhofer Institute for Graphics, Darmstadt, Germany and received his PhD degree in July 2002. From July 2006 to Sept. 2008, Dr. CHEN was a visiting scholar at Purdue University, working in PURPL with Prof. David S. EBERT. He is also a visiting professor of NUS and a CO-PI of SeSame center, Singapore. His current research interests include visualization and visual analytics.