

Mingyu LI, Xiaobing CHENG, Zhijiang DAI, Kang ZHONG, Tianfu CAI, Chaoyi HUANG, 2023. A novel method for extending the output power back-off range of an asymmetrical Doherty power amplifier. *Frontiers of Information Technology & Electronic Engineering*, 24(3):470-479. <https://doi.org/10.1631/FITEE.2200250>

A novel method for extending the output power back-off range of an asymmetrical Doherty power amplifier

Key words: Doherty power amplifier; Output power back-off; Output impedance; Network phase

Corresponding author: Zhijiang DAI

E-mail: daizj_ok@126.com

 ORCID: <https://orcid.org/0000-0003-4914-1464>

Motivation

The rapid development of wireless communication systems has changed our lives. Five-generation wireless communication (5G) is characterized by high data rate, massive connections, and low latency, which will cause a larger signal peak-to-average power ratio. Therefore, improving the efficiency of the amplifier in the output power back-off (OPBO) state is beneficial to improving the overall performance of the transmitter system.

Main idea

A novel method is proposed to extend the OPBO range of the Doherty power amplifier (DPA). This study reveals that the OPBO range of the DPA can be extended by tuning the output impedance of the peaking stage away from infinity and changing the phase delay of the output matching network of the carrier power amplifier. Based on this theory, a large-OPBO-range high-efficiency asymmetrical DPA working band from 1.55 to 2.2 GHz (35% relative bandwidth) is designed to verify the proposed method.

Framework

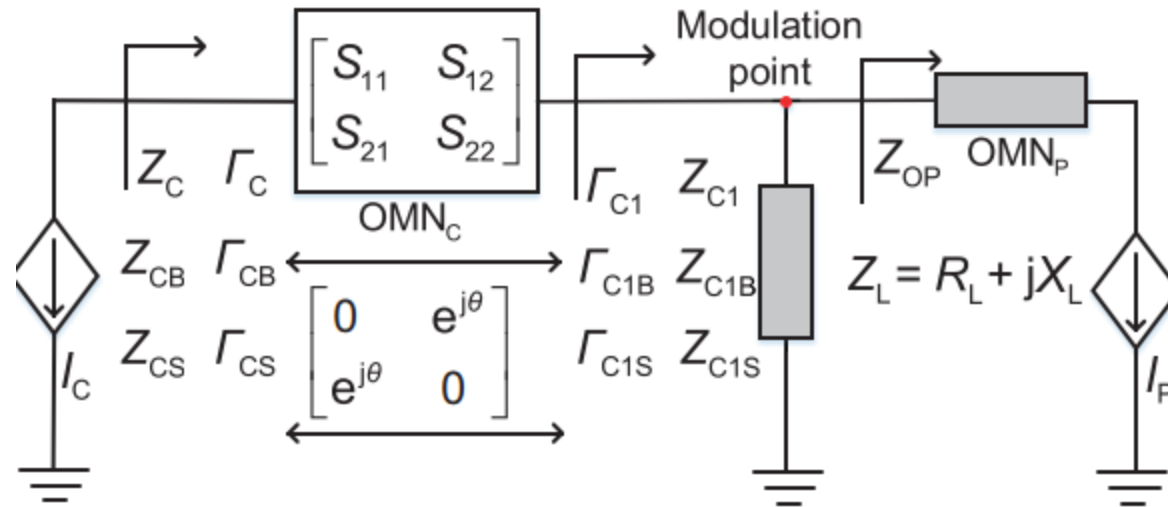

The asymmetric DPA block diagram consists of a carrier transistor, a peak transistor, the output matching network of the carrier power amplifier (OMNC), the output matching network of the peak power amplifier, and the impedance looking into the load from the modulation point.

Method

Low power matching

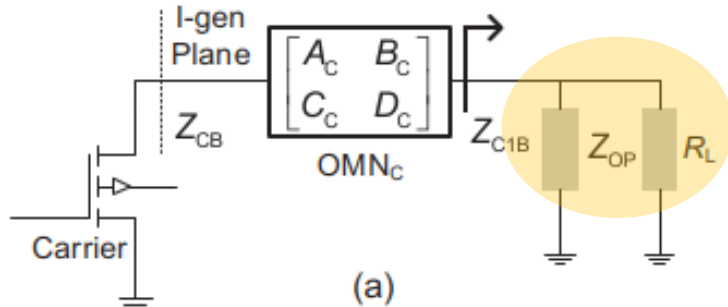

Load modulation

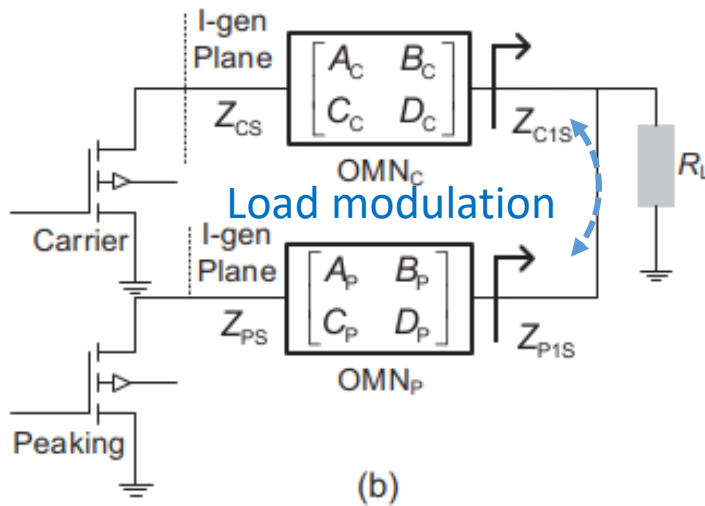

High power matching

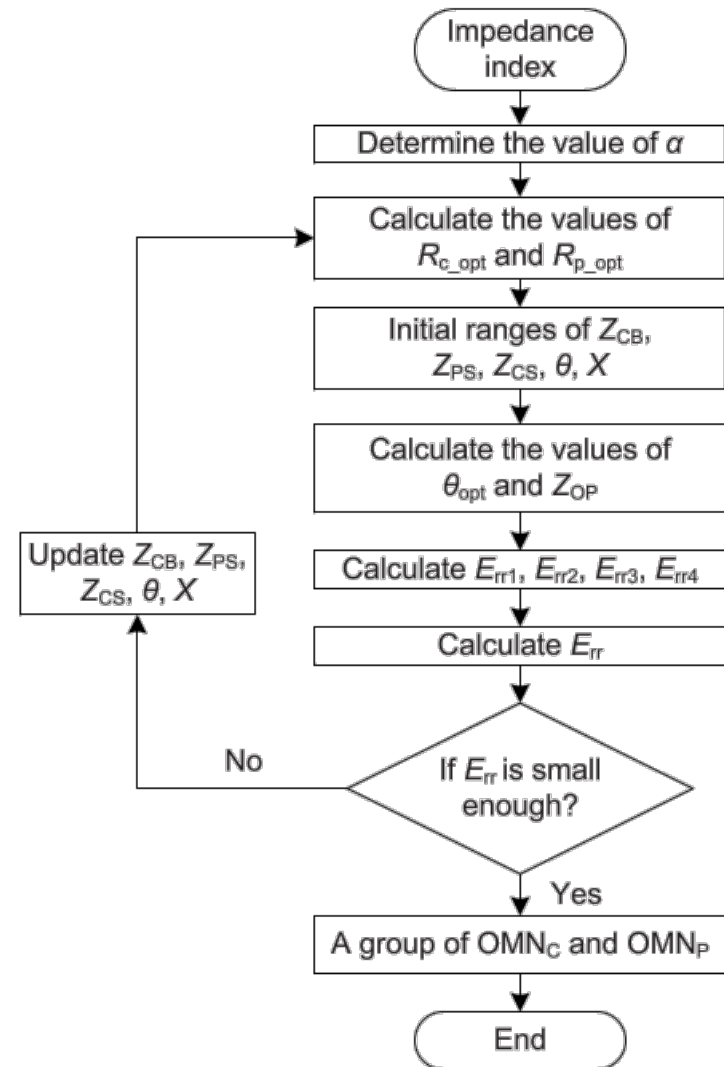

Algorithm flowchart of design OMN_C and OMN_P

Major results

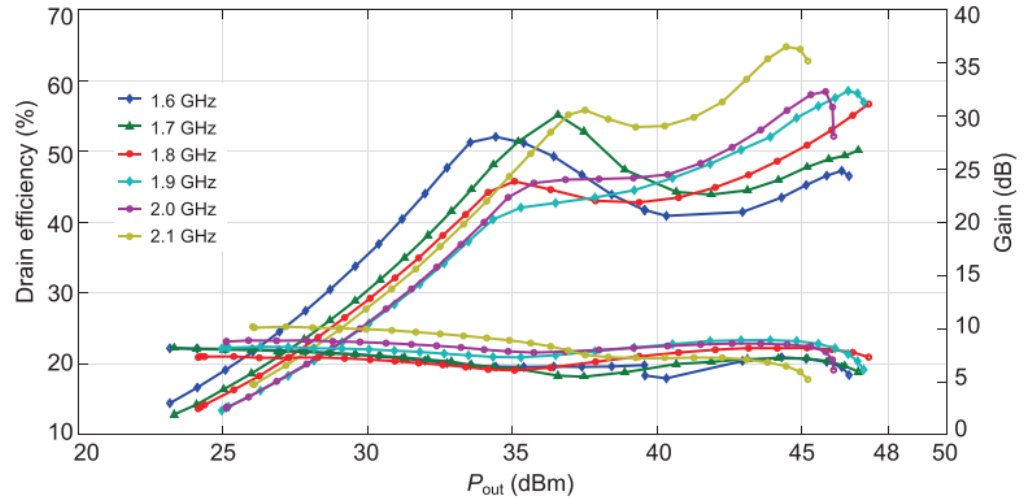
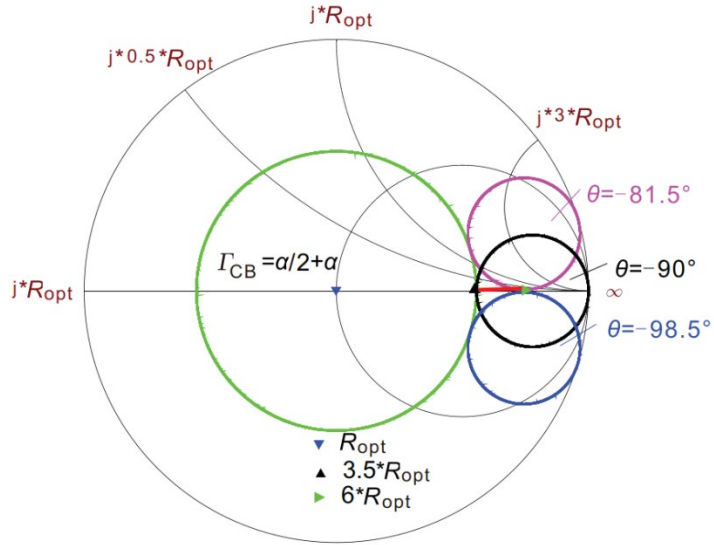

Table 1 Comparison between our Doherty power amplifier (DPA) and some DPAs in the literature

Reference	Frequency (GHz)	FBW (%)	Power (dBm)	OPBO (dB)	Eff-OPBO (%)	Eff-sat (%)
Özen et al., 2016	1.95	–	44	9	50	–
Hasin and Kitchen, 2019	2.2	–	43.6	9	50.7	71
Li C et al., 2019	1.9–2.4	23.2	44.1–44.8	8.5–9	44.2–49.7	65.2–71.8
Fang et al., 2018	1.35–1.7	22.9	42	9	50–56	71–76
This work	1.6–2.1	27	45.2–47.3	11.1–13.2	42.2–52.1	47–62.7

FBW: fractional bandwidth; OPBO: output power back-off; Eff-OPBO: efficiency in the OPBO state; Eff-sat: efficiency in the saturation state

Conclusions

- This paper presents a method for extending the OPBO range of the DPA. To verify the theory, a novel method of asymmetrical DPA with a large OPBO range is designed.
- Experimental results show that the designed asymmetric DPA operates at 1.6–2.1 GHz. The OPBO range is 11.1–13.2 dB and the maximum output power is 45.2–47.3 dBm. The efficiency range is 42.2%–52.1% in the OPBO state and 47%–62.7% in the saturation state. The theory can also be used to develop a symmetrical DPA.



Mingyu LI received his PhD degree in electronic engineering from University of Electronic Science and Technology of China, Chengdu, China in 2009. From 2012 to 2013, he was a Research Fellow at University of Kitakyushu, Kitakyushu, Japan. He is currently an Associate Professor with the School of Microelectronics and Communication Engineering, Chongqing University, Chongqing, China. His current research interests include RF/microwave transceiver design, statistical and adaptive signal processing for wireless communications, and behavioral modeling and linearization for RF power amplifiers.



Xiaobing CHENG received his BS degree in electronic information engineering from Chongqing Jiaotong University, Chongqing, China in 2018, and his MS degree in microelectronics and communication engineering from Chongqing University, Chongqing, China in 2022. His current research interests include broadband high-efficiency power amplifiers and Doherty power amplifiers.



Zhijiang DAI received his BS and PhD degrees in electrical engineering from University of Electronic Science and Technology of China, Chengdu, China in 2011 and 2017, respectively. From 2017 to 2018, he was a Research Engineer at Huawei Technologies, where he focused on the study of MIMO wireless communication systems. He is currently a Lecturer with the School of Microelectronics and Communication Engineering, Chongqing University, Chongqing, China. His research interests include automatic matching techniques of PA, wideband and linear RF PA design, MMIC circuits, and wireless communication systems.



Kang ZHONG received his BS degree in electronic information engineering from Guizhou University, Guiyang, China in 2021. He is currently pursuing his MS degree at the School of Microelectronics and Communication Engineering, Chongqing University, Chongqing, China. His current research interests include broadband high-efficiency power amplifiers and load modulated power amplifiers.



Tianfu CAI received his BS degree in communication engineering from Harbin Engineering University, Harbin, China in 2019. He is currently pursuing his PhD degree at School of Microelectronics and Communication Engineering, Chongqing University, Chongqing, China. His research interests include communication signal processing and digital predistortion implementation in FPGA.

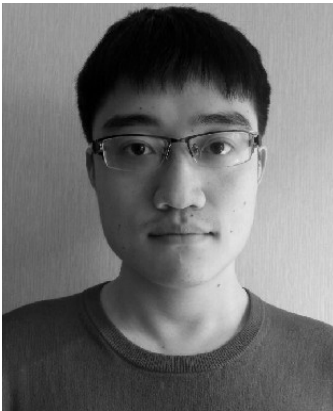

Chaoyi HUANG received his BS degree in electronic information engineering from University of Electronic Science and Technology of China (UESTC), Chengdu, China in 2011, and his PhD degree in circuits and systems from UESTC in 2018. He is currently a Lecturer with the School of Optoelectronic Engineering, Chongqing University of Posts and Telecommunications, Chongqing, China. He is now engaged in research on design techniques for broadband power amplifiers with high back-off efficiency.