

Yujia ZANG, Yanhu CHEN, Canjun YANG, Haoyu ZHANG, Zhiyong DUAN, Gul MUHAMMAD, 2021. A stepless-power-reconfigurable converter for a constant current underwater observatory. *Frontiers of Information Technology & Electronic Engineering*, 22(12):1625-1640. <https://doi.org/10.1631/FITEE.2100259>

A stepless-power-reconfigurable converter for a constant current underwater observatory

Key words: Constant current to constant voltage (CC/CV) conversion; Shunt regulator; Stepless power configuration; Underwater observatory

Corresponding author: Yanhu CHEN

E-mail: yanhuchen@zju.edu.cn

 ORCID: <https://orcid.org/0000-0002-5020-7355>

Motivation & main idea

In a constant current (CC) underwater observatory with a shunt regulator:

- if the load power is kept at a high level, this results in a low level of heat dissipation on the balance-load (BL), as shown in figure (a);
- if the load power is kept at a low level, an unnecessary power margin is possibly left on the BL, leading to a waste of power, as shown in figure (b);

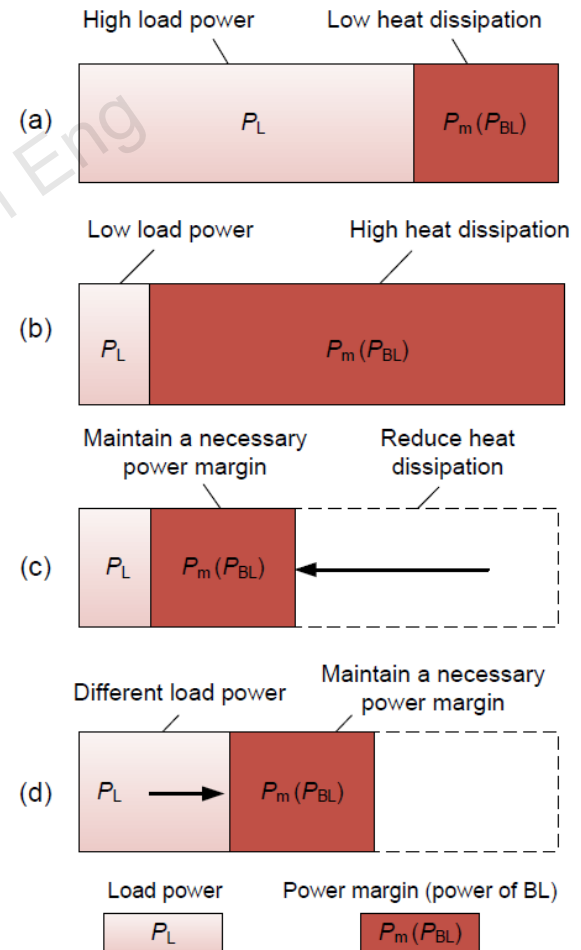

Motivation & main idea (Cont'd)

- when adjusting the power of BL steplessly, only a reasonable power margin can be reserved for the system to prevent the power failure caused by sudden load rise, as shown in figure (c);
- if the load changes slowly, the strategy in this study adjusts the power of BL automatically to ensure that the power margin of the system is kept in a necessary range, as shown in figure (d).

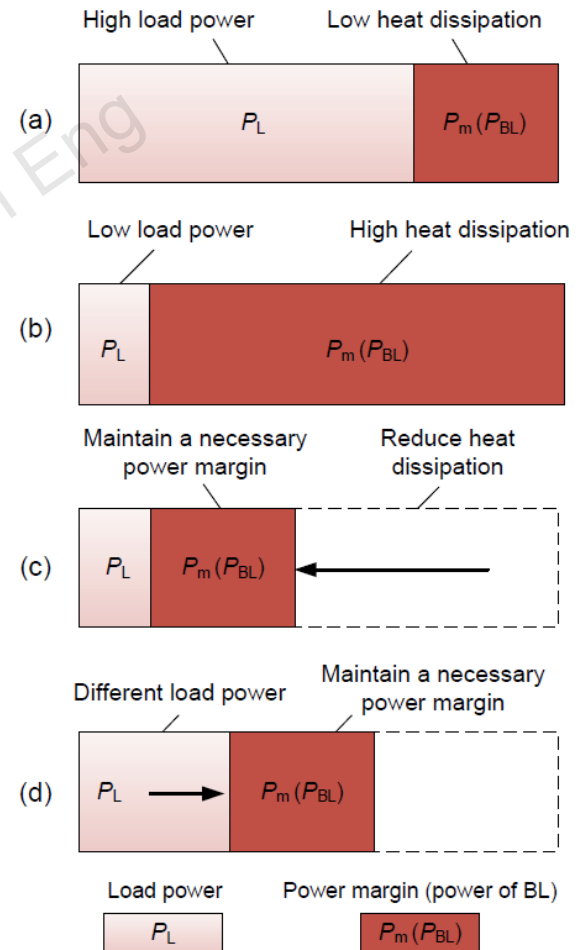

Method

1. Block diagram of the stepless-power-reconfigurable CC/CV module

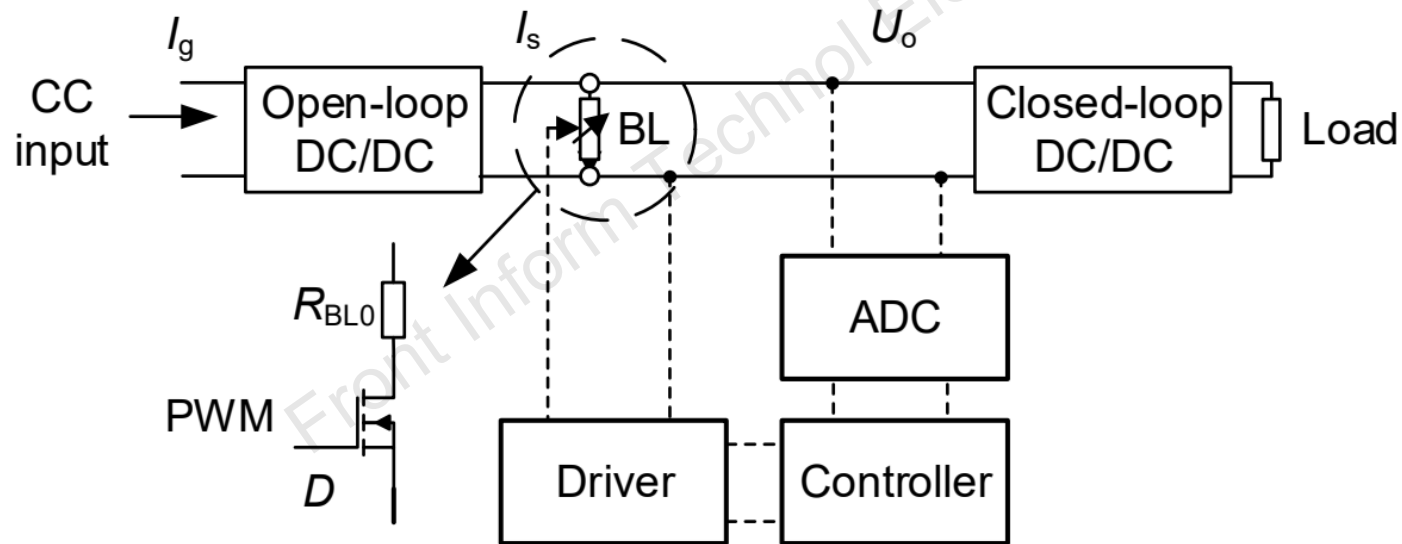

Method (Cont'd)

2. Block diagram of the inner-outer loop control strategy

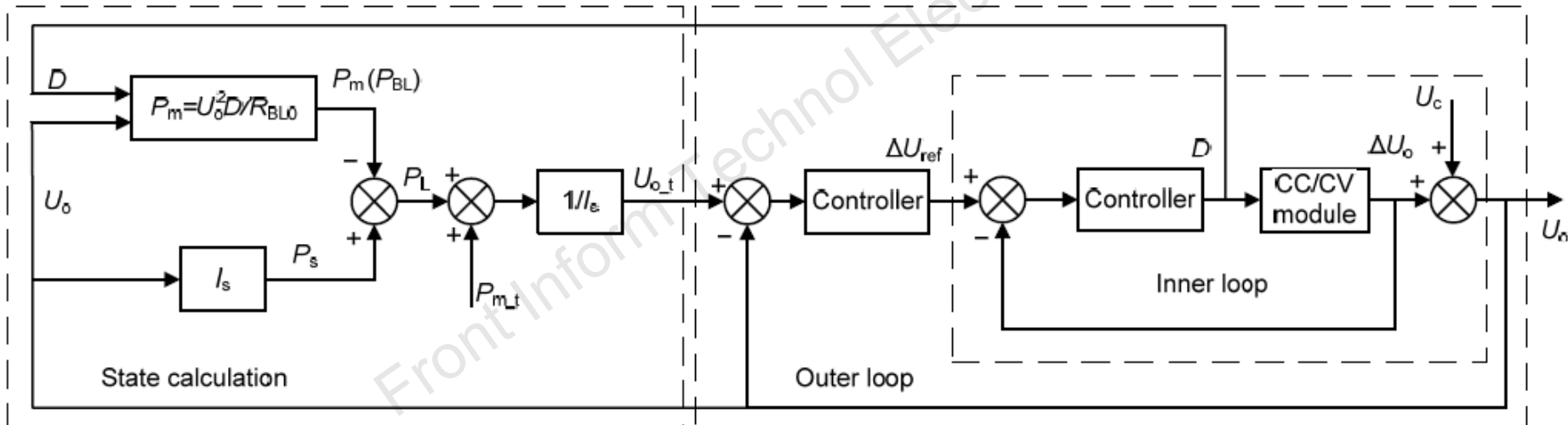

Method (Cont'd)

3. Key technologies of the stepless-power reconfigurable converter

Stepless-power-reconfigurable CC/CV converter

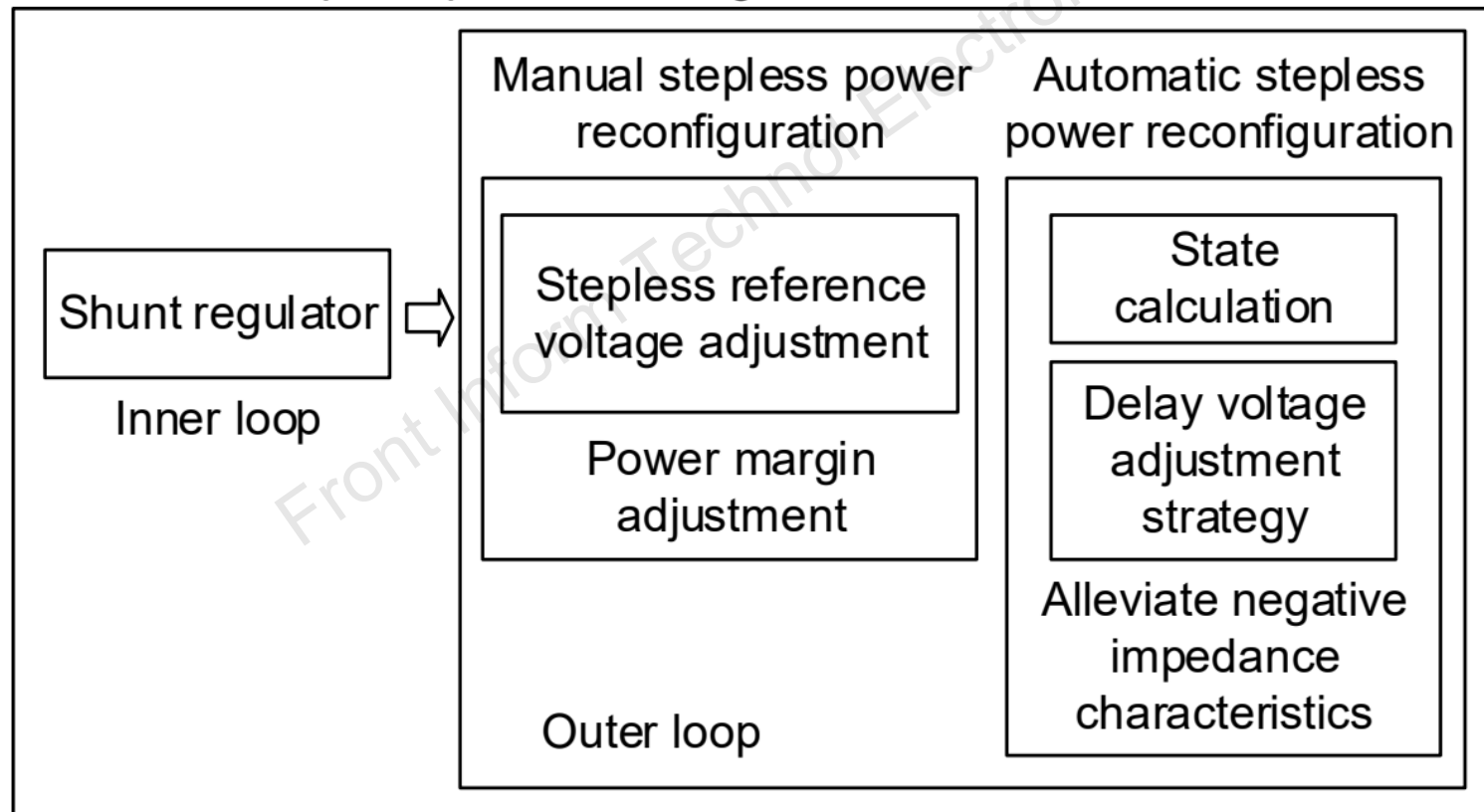

Major results

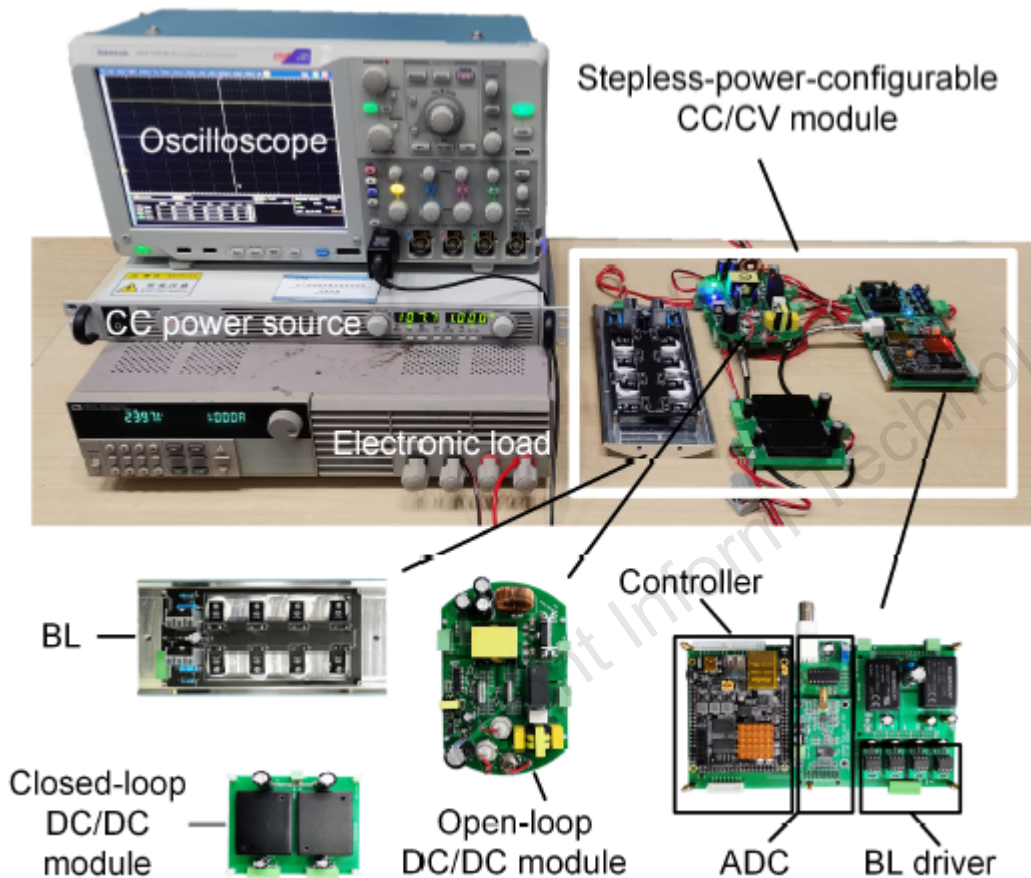

Setup of the experiment

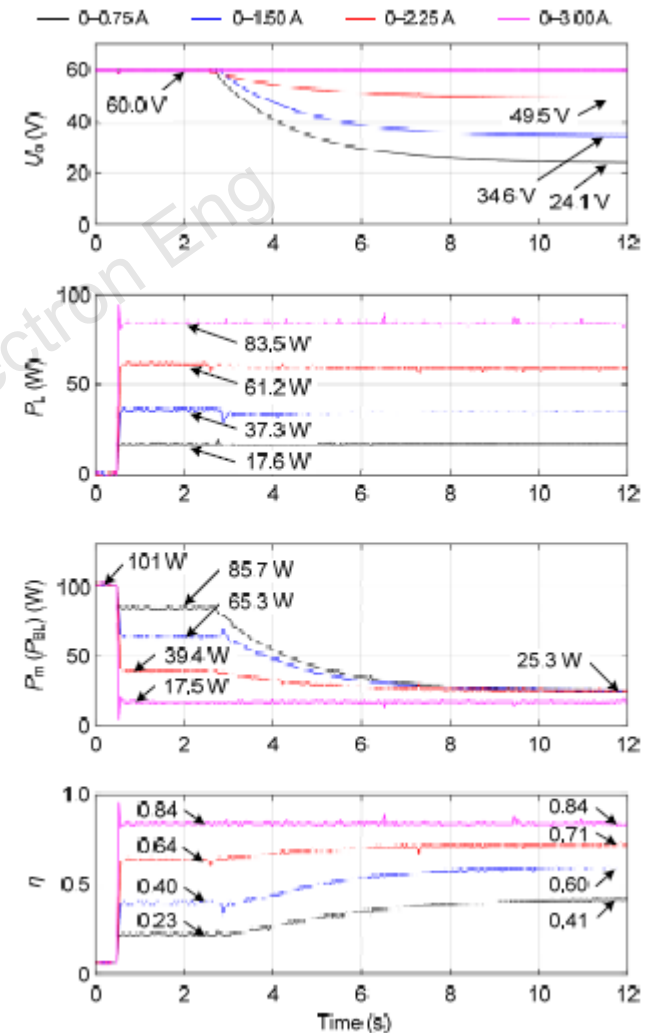

Experimental results under the strategy with load starting up

Major results (Cont'd)

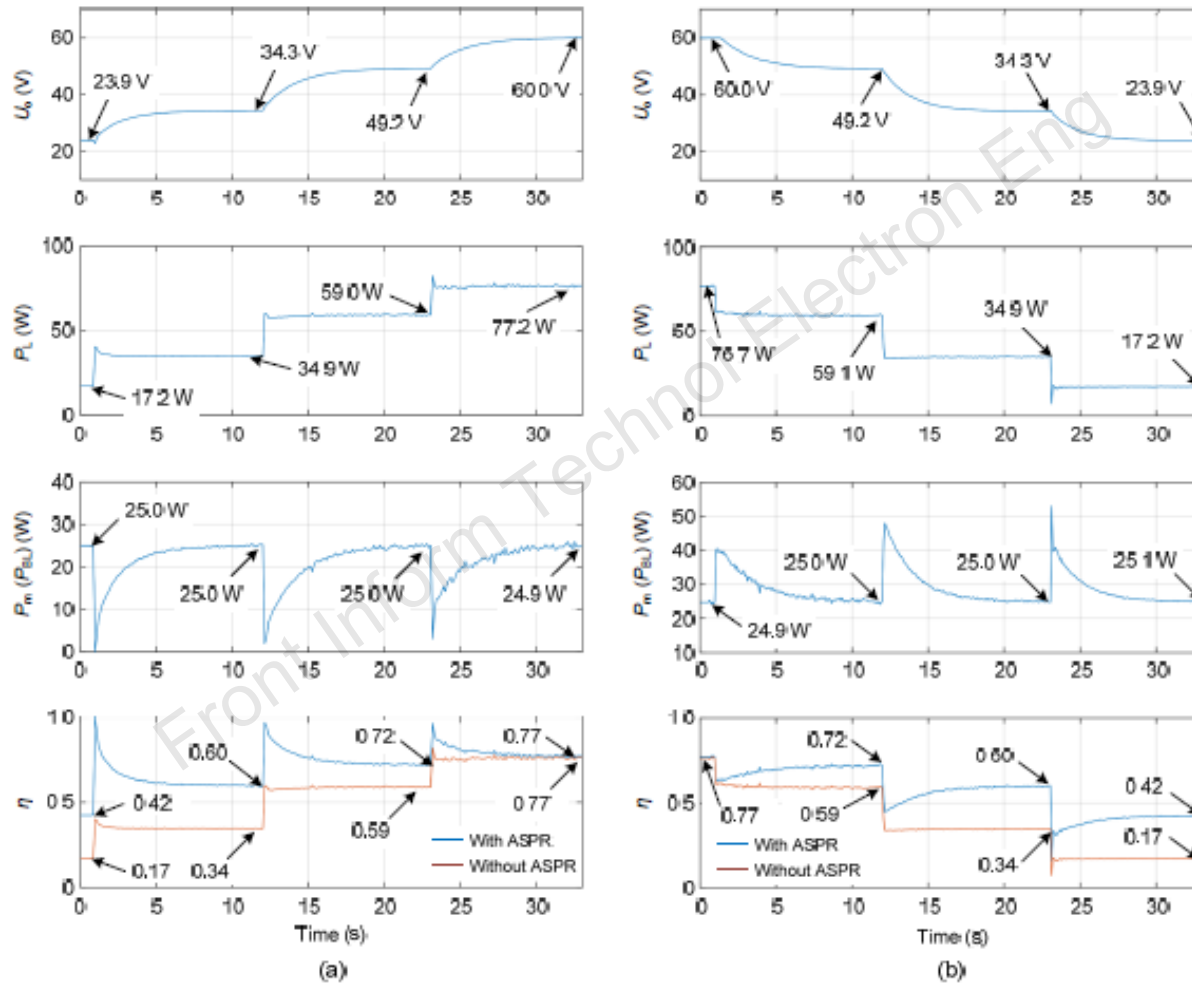

Experimental results with load in stepped variation: (a) load steps up; (b) load steps down

Major results (Cont'd)

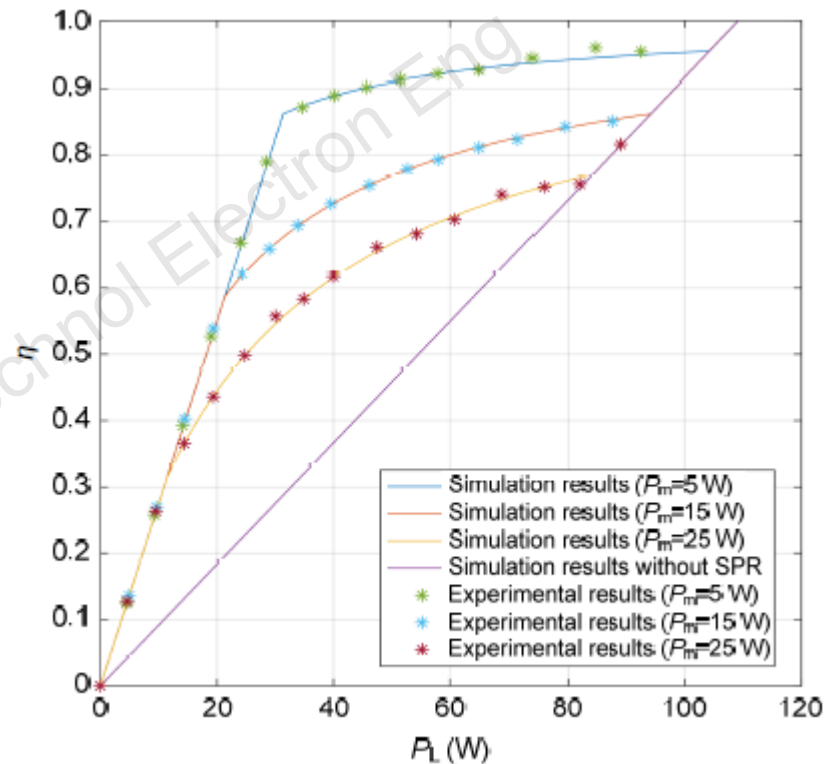
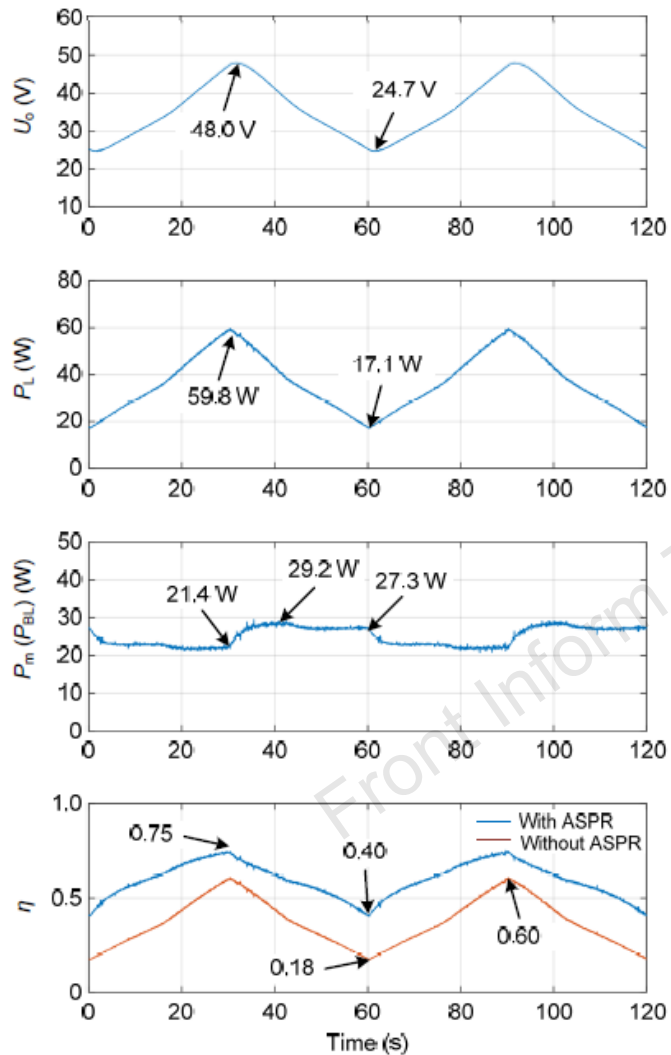

Results of efficiency

Experimental results with load in continuous variation

Conclusions

- The concept of stepless power reconfiguration (SPR), which is a novel active shunt regulation method that can be used in the CC/CV converter, has been introduced.
- Two effective and practical methods named manual SPR (MSPR) and automatic SPR (ASPR) have been discussed. They can steplessly reconfigure the system power manually and automatically, respectively, to reduce the unnecessary dissipation of the system and greatly improve the efficiency compared with the traditional shunt regulation methods, while ensuring the stability of the system.
- The experimental results showed that the steady-state efficiency of the stepless power reconfiguration can be increased up to 1.47 times that of a typical shunt regulator.

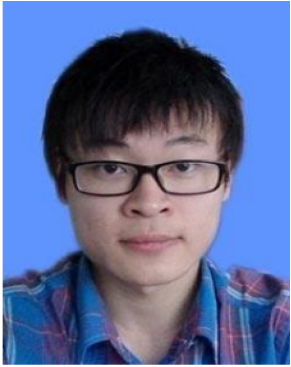

Yujia ZANG received the BS degree in mechatronic engineering from Yanshan University, Qinhuangdao, China, in 2016 and PhD degree in mechanical engineering from Zhejiang University, China, in 2021. His research interests include intelligent control, cabled ocean observation, and constant current power conversion & transmission.



Yanhu CHEN received the BS and PhD degrees in mechanical engineering from Zhejiang University, China, in 2007 and 2012, respectively. He was a post-doctoral research fellow with the Department of Ocean and Resources Engineering, University of Hawaii in 2013 and has been an associate professor with the Institute of Mechatronics Control Engineering, Zhejiang University, since 2014. His research interests include cabled ocean observation, underwater power management, and underwater robot. He made effort on building the Chinese first regional cable observation system in South China Sea.