



Design of a novel RTD-based three-variable universal logic gate^{*}

Mao-qun YAO^{†1}, Kai YANG¹, Cong-yuan XU², Ji-zhong SHEN²

⁽¹⁾Hangzhou Institute of Service Engineering, Hangzhou Normal University, Hangzhou 311121, China)

⁽²⁾College of Information Science & Electronic Engineering, Zhejiang University, Hangzhou 310027, China)

[†]E-mail: yaomaqun@163.com

Received Mar. 30, 2015; Revision accepted July 2, 2015; Crosschecked July 24, 2015

Abstract: Traditional CMOS technology faces some fundamental physical limitations. Therefore, it has become very important for the integrated circuit industry to continue to develop modern devices and new design methods. The threshold logic gate has attracted much attention because of its powerful logic function. The resonant tunneling diode (RTD) is well suited for implementing the threshold logic gate because of its high-speed switching capability, negative differential resistance (NDR) characteristic, and functional versatility. In this paper, based on the Reed-Muller (RM) algebraic system, a novel method is proposed to convert three-variable non-threshold functions to the XOR of multiple threshold functions, which is simple and has a programmable implementation. With this approach, all three-variable non-threshold functions can be presented by the XOR of two threshold functions, except for two special functions. On this basis, a novel three-variable universal logic gate (ULG3) is proposed, composed of two RTD-based universal threshold logic gates (UTLG) and an RTD-based three-variable XOR gate (XOR3). The ULG3 has a simple structure, and a simple method is presented to implement all three-variable functions using one ULG3. Thus, the proposed ULG3 provides a new efficient universal logic gate to implement RTD-based arbitrary n -variable functions.

Key words: Resonant tunneling diode (RTD), Threshold logic gate, Reed-Muller expansion, Universal logic gate

doi:10.1631/FITEE.1500102

Document code: A

CLC number: TN47

1 Introduction

With the development of the integrated circuit, traditional complementary metal-oxide semiconductor (CMOS) technology is gradually reaching its physical limitations. Compared to CMOS, a resonant tunneling diode (RTD) has better performance and features, such as negative differential resistance (NDR), high speed, self-latching, and low power consumption (Mazumder *et al.*, 1998; Muramatsu *et al.*, 2005), and is the most promising candidate to form the basis of the next generation of integrated circuit devices (Likharev, 2008; Lee *et al.*, 2010).

A universal logic gate is a powerful circuit unit used as one of the basic modules of very large scale integration (VLSI) (Chen and Hurst, 1981). The threshold gate has a powerful logic function and a structure similar to that of artificial neurons, and has attracted much attention. An RTD is more suitable for implementing the threshold logic gate because of its negative differential resistance characteristics (Beiu *et al.*, 2003; Zheng and Huang, 2009; Mirhoseini *et al.*, 2010).

There are 2^{2^n} n -variable functions, and thus there are 256 three-variable functions and 2^{16} four-variable functions. A universal logic gate that can implement the four-variable functions will be relatively complicated, while a universal logic gate that can implement only the bivariate functions will have only a simple function. Therefore, a universal logic gate which can implement three-variable functions is a reasonable choice. Some synthesis algorithms based

^{*} Project supported by the National Natural Science Foundation of China (Nos. 61271124 and 61471314) and the Zhejiang Provincial Natural Science Foundation of China (Nos. LY13F010001 and LY15F010011)

ORCID: Mao-qun YAO, <http://orcid.org/0000-0001-6484-4972>
 © Zhejiang University and Springer-Verlag Berlin Heidelberg 2015

on the RTD threshold logic gate and universal logic gate have been proposed (Wu and Hurst, 1981; Zhang et al., 2005; Bawiec and Nikodem, 2009). Wei and Shen (2011) designed a three-variable universal threshold logic gate (UTLG) that can implement all three-variable threshold functions and has a simple circuit connection. However, it has some disadvantages: a single UTLG can implement only three-variable threshold functions, and needs multiple UTLGs to realize three-variable non-threshold functions; the algorithm that decomposes a non-threshold function into several threshold functions is relatively complex.

In this paper, a novel method is proposed to convert a three-variable non-threshold function to the XOR of multiple threshold functions. Then a three-variable universal logic gate (ULG3) based on UTLG is proposed, which can implement an arbitrary three-variable function with a single ULG3.

2 Background

2.1 Threshold logic

A threshold gate (TG) (Muroga, 1971) is defined as a logic gate with n binary input variables, $\{x_i\}$ ($i=1, 2, \dots, n$), and a single binary output y . Its internal parameters are a set of n positive or negative weights, $\{w_i\}$ ($i=1, 2, \dots, n$), and a threshold T , such that its input-output relationship is

$$y = \begin{cases} 1, & \sum_{i=1}^n w_i x_i \geq T, \\ 0, & \text{otherwise.} \end{cases} \quad (1)$$

A TG can also be presented as $f = \langle w_1 x_1 + w_2 x_2 + \dots + w_n x_n \rangle_T$.

If a logic function can be implemented with a single threshold logic gate, the function is called a threshold function. Otherwise, it is called a non-threshold function.

Because Boolean logic can be expressed by threshold logic, a threshold function is functionally complete (Zhang et al., 2005). In terms of performance and complexity, TGs implement conventional Boolean gates efficiently and have more complex functions (Zhang et al., 2005).

2.2 Spectral technology

Spectral technology is a mathematical transformation method. It is used to convert binary data from the conventional Boolean domain $\{0, 1\}$ into the spectral domain $\{+1, -1\}$ by matrix transformations, with no loss of information (Hurst, 1978). Within the spectral domain, a wider set of numbers are involved, ranging in even-integer values from -2^n to $+2^n$ for any n input variables, which gives us more information than that of the conventional Boolean domain (Hurst, 1978).

Given an n -variable function $f(x_1, x_2, \dots, x_n)$, the spectral-coefficient vector R is given by

$$R = RW^n \cdot F, \quad (2)$$

where RW^n is a $2^n \times n$ Rademacher-Walsh matrix, and F is the function output matrix of the function in the Boolean domain.

As for a three-variable function, the spectral-coefficient is $R = [r_0 \ r_3 \ r_2 \ r_{23} \ r_1 \ r_{13} \ r_{123}]^T$, where r_0 is a zero-order spectral-coefficient, and r_i, r_{ij}, r_{ijk} are one-, two-, and three-order spectral-coefficients, respectively.

2.3 Reed-Muller expansion

A Reed-Muller expansion is a canonical expansion in the AND/XOR algebraic system. A given function can be expressed as the XOR of basic entry and its coefficient is called the RM expansion coefficient (Kodandapani and Setlur, 1997). Given an n -variable function $f(x_1, x_2, \dots, x_n)$, its RM expansion coefficient vector B is

$$B = K_n \cdot F, \quad (3)$$

where K_n is a Kronecker matrix.

As for a three-variable function $f(x_1, x_2, x_3)$, its RM expansion is

$$f(x_1, x_2, x_3) = b_0 \oplus b_1 x_3 \oplus b_2 x_2 \oplus b_3 x_2 x_3 \oplus b_4 x_1 \oplus b_5 x_1 x_3 \oplus b_6 x_1 x_2 \oplus b_7 x_1 x_2 x_3. \quad (4)$$

3 Design of three-variable universal logic gate

In this section, a new method for converting a three-variable non-threshold function to XOR of multiple threshold functions is proposed. With this

method, a novel three-variable universal logic gate is designed based on UTLG.

3.1 Classification of the threshold functions

Hurst *et al.* (1985) proposed a spectral-coefficient classification for threshold functions. The spectral-coefficient classification for all the three-variable threshold functions is given in Table 1.

Table 1 Spectral-coefficient $|r_i|$ classification for all the three-variable threshold functions

| Case | $ r_i $ | | | $ a_i $ | | | | |
|------|---------|---|---|---------|---|---|---|---|
| 1 | 8 | 0 | 0 | 0 | 1 | 0 | 0 | 0 |
| 2 | 6 | 2 | 2 | 2 | 2 | 1 | 1 | 1 |
| 3 | 4 | 4 | 4 | 0 | 1 | 1 | 1 | 0 |

Some conclusions should be noted as follows:

1. Compute the zero- and one-order spectral-coefficients for a given three-variable function and arrange them in numerically descending order of magnitude, and this is the $|r_i|$ of the function; if the $|r_i|$ appears in Table 1, the function is a threshold function. The $|a_i|$ against the appropriate $|r_i|$ can be used to derive the integer w_i and T for the threshold function. The relationship between the $|w_i|$ and listed $|a_i|$ value is

$$|w_i|=|a_i|, \quad i=0, 1, 2, 3. \quad (5)$$

The sign of w_i is the same as that of r_i . The threshold T can be calculated as

$$T = \frac{1}{2} \left(\sum_{i=0}^3 a_i + 1 \right). \quad (6)$$

2. If the function is not a threshold function, the derived number $|r_i|$ will not appear in Table 1.

3.2 Non-threshold function conversion

Several studies have proposed methods to convert a non-threshold function to multiple threshold functions (Lechner, 1971; Bawiec and Nikodem, 2009; Nikodem and Bawiec, 2010), but they have two shortcomings. First, the function after conversion is not the original function and the input variables need some transformation; second, the process of conversion is quite complex.

For all the three-variable functions, there are 104 threshold functions and 152 non-threshold functions

(Hurst *et al.*, 1985).

In this paper, a novel function decomposition approach is proposed to convert a three-variable non-threshold function to the XOR of multiple threshold functions with Reed-Muller expansion and spectral technology applied. The decomposition process is as follows:

1. Calculate the RM expansion coefficients of all the three-variable threshold functions as a reference table.

2. Calculate the RM expansion coefficients of the function to be converted.

3. Through the sequential search method, search the reference table of step 1, to find the two threshold functions for which the XOR result of their RM expansion coefficients equals the calculated RM expansion coefficients of step 2.

4. The three-variable non-threshold function can be expressed as the XOR of the found threshold functions of step 3.

Through the exhaustive method, calculating all the three-variable non-threshold functions by this decomposition, we can draw a conclusion: All the three-variable non-threshold functions, except two special functions, $f=x_1 \oplus x_2 \oplus x_3$ and $f = \overline{x_1 \oplus x_2 \oplus x_3}$, can be presented by the XOR of two threshold functions, i.e., $f(x_1, x_2, x_3)=f_1(x_1, x_2, x_3) \oplus f_2(x_1, x_2, x_3)$, where f_1 and f_2 are threshold functions.

3.3 Implementation of the three-variable universal logic gate

All the three-variable threshold functions can be implemented using a UTLG (Wei and Shen, 2011). Fig. 1 shows a schematic and the UTLG symbol. Only input bits need to be reconfigured and there is no need to change the parameters of RTD or MOSFET while implementing a threshold function with UTLG.

As discussed above, all the non-threshold functions can be presented by the XOR of two threshold functions except two special functions, $f=x_1 \oplus x_2 \oplus x_3$ and $f = \overline{x_1 \oplus x_2 \oplus x_3}$. These functions cannot be presented by the XOR of two threshold functions because the XOR function is not a threshold function and the bivariate XOR function cannot be implemented by a single UTLG.

To design a universal logic gate which can implement all the three-variable functions, and

according to the properties of the XOR function, $f = \overline{x_1 \oplus x_2 \oplus x_3} = \overline{x_1} \oplus x_2 \oplus x_3$. Therefore, a three-variable XOR gate should be a part of the universal logic gate.

An RTD three-variable XOR gate (XOR3) was designed according to the MOBILE circuit structure (Chen et al., 1995). Fig. 2 shows a schematic and the symbol for XOR3. Fig. 3 shows the results of simulation of the XOR3 circuit by HSPICE, using the same parameters of RTD and MOSFET as used by the UTLG circuit (Wei and Shen, 2011). The proposed XOR3 clearly has the correct logic functionality.

A ULG3 was then designed, consisting of two UTLGs and an XOR3 gate with 13 inputs c_1-c_{13} and an output f (Fig. 4). Two UTLGs implement two threshold functions by configuring their inputs c_1-c_6 and c_8-c_{13} (Wei and Shen, 2011). Input c_7 connected to x_3 is used to implement two special non-threshold functions, while in the other situation it connects to 0. So, every three-variable function can be implemented using a single ULG3.

The following examples demonstrate how to implement a three-variable function using ULG3 and compare the use of ULG3 and UTLGs.

Example 1 Implement the three-variable function $f = \overline{x_1} \overline{x_2} x_3 + x_1 \overline{x_3}$.

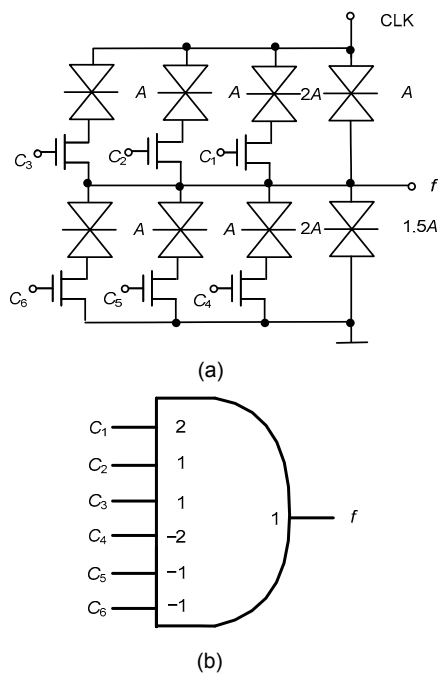

Fig. 1 The universal threshold logic gate (UTLG)
(a) Schematic; (b) Symbol

Function f is a non-threshold function. Its RM expansion coefficient is $\mathbf{B}=[0\ 1\ 0\ 1\ 1\ 0\ 0\ 1]$ and can be expressed as the XOR of two threshold functions by the proposed method, $f=f_1 \oplus f_2$, where $f_1 = x_1 \overline{x_2} + \overline{x_2} x_3 + x_1 x_3$ and $f_2 = x_1 x_2 + x_1 x_2$. Fig. 5 shows the ULG3 implementation of this function.

Example 2 Implement the three-variable function $f = \overline{x_1} \overline{x_2} + \overline{x_1} \overline{x_3} + \overline{x_2} \overline{x_3} + x_1 x_2 x_3$.

The function f is a non-threshold function. Its Reed-Muller expansion coefficient is $\mathbf{B}=[1\ 0\ 0\ 1\ 0\ 1\ 1\ 1]$ and can be expressed as the XOR of two threshold functions, $f=f_1 \oplus f_2$, $f_1 = x_1 x_2 x_3$, $f_2 = \overline{x_1} \overline{x_2} + \overline{x_1} \overline{x_3} + \overline{x_2} \overline{x_3}$. Fig. 6 shows the ULG3 implementation of this example.

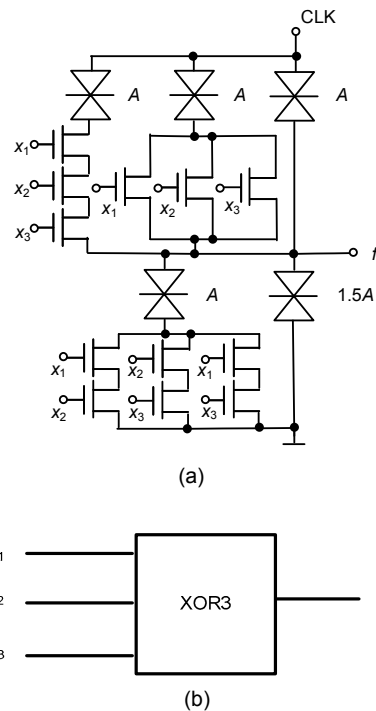

Fig. 2 Three-variable XOR gate (XOR3)
(a) Schematic; (b) Symbol

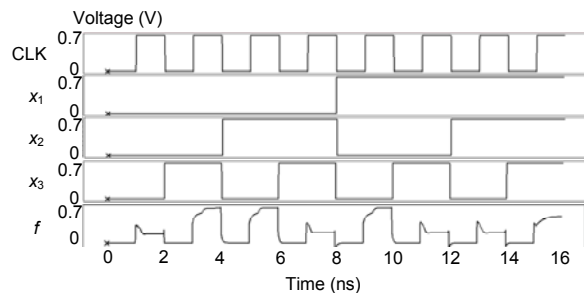

Fig. 3 Transient waveforms of the proposed XOR3

If UTLG is used to implement the function in Example 2, first we need to replace x_1 with $x_1 \oplus x_2$ to obtain function f' . We then create f'' from $f' \oplus x_3$ (Wei and Shen, 2011). Finally, a function decomposition would be applied to obtain four threshold functions: $f = f_1 + f_2 + f_3 + f_4$, where $f_1 = x_1 x_2 x_3$, $f_2 = \bar{x}_1 \bar{x}_2 x_3$, $f_3 = \bar{x}_1 x_2 \bar{x}_3$, and $f_4 = \bar{x}_2 \bar{x}_3$. Fig. 7 shows the UTLG implementation of this function.

Table 2 shows the number of ULG3s or UTLGs which implement the three-variable non-threshold function. Obviously, compared to UTLG, the circuit in which ULG3 implements the three-variable non-

threshold function is simpler. When the given three-variable function is a threshold function, both one ULG3 and one UTLG are needed to implement the function. However, UTLG is simpler than ULG3, and thus using UTLG to implement the three-variable threshold function and using ULG3 to implement the three-variable non-threshold function are reasonable.

4 Conclusions

In this paper, a novel approach is proposed to convert a three-variable non-threshold function into

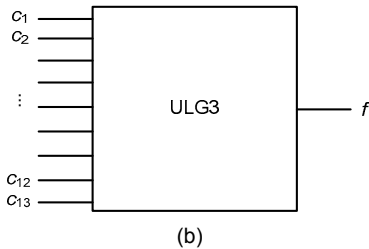
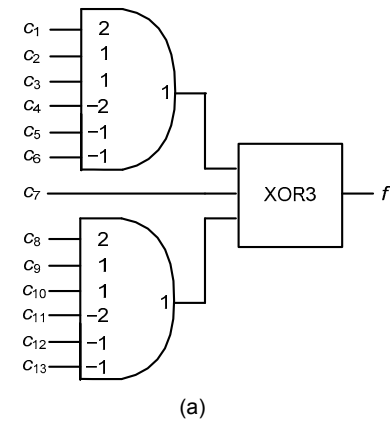

Fig. 4 Three-variable universal logic gate (ULG3) (a) Schematic; (b) Symbol

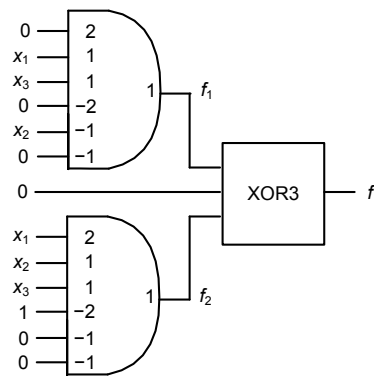

Fig. 5 ULG3 implementation of Example 1

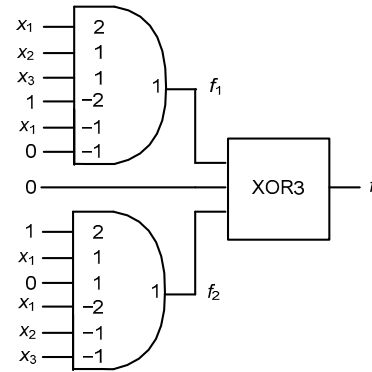

Fig. 6 ULG3 implementation of Example 2

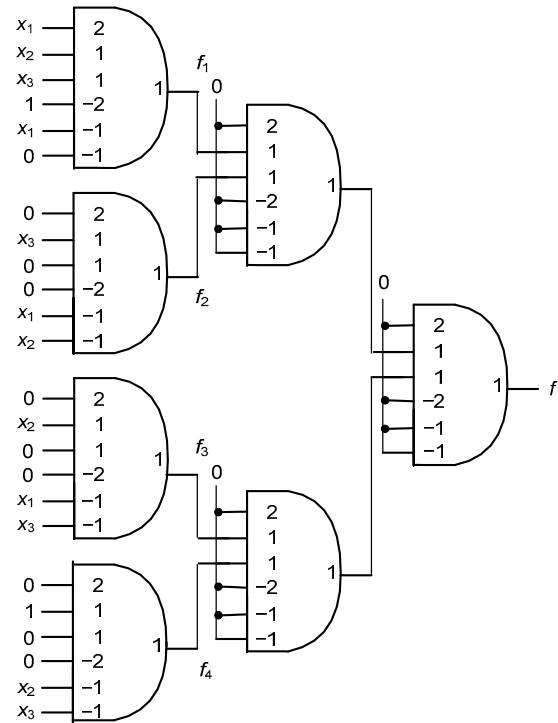

Fig. 7 UTLG implementation of Example 2

Table 2 Numbers of ULG3 or UTLG implementing the three-variable non-threshold function

| Device name | Number of functions | Device number/function | Average device number/function | Average number of RTDs/function | Average number of MOSFETs/function | Average number of RTDs+MOSFETs/function |
|-------------|---------------------|------------------------|--------------------------------|---------------------------------|------------------------------------|---|
| ULG3 | 152 | 1 | 1 | 21 | 24 | 45 |
| UTLG | 134 | 3 | 3.47 | 27.76 | 20.82 | 48.58 |
| | 18 | 7 | | | | |

the XOR of multiple threshold functions, which is very simple and easy to program. With this approach, all the three-variable non-threshold functions can be presented by the XOR of two threshold functions except for two special non-threshold functions. Then a novel three-variable universal logic gate (UTG3) is proposed, which consists of two UTLGs and an XOR3 gate. To implement different three-variable threshold functions, only one UTG3 is needed which configures the inputs. Also, there is no need to vary the structure or internal circuit parameters of the RTD in UTG3.

ULG3 is simpler for realizing three-variable non-threshold functions, while UTLG is better for three-variable threshold functions. Therefore, the proposed ULG3 improves the RTD-based three-variable universal logic gate, and provides a simple and efficient circuit module to implement RTD-based arbitrary n -variable functions. Further research will focus on the implementation of arbitrary n -variable functions with ULG3s and UTLGs.

References

- Bawiec, M.A., Nikodem, M., 2009. Boolean logic function synthesis for generalized threshold gate circuits. Proc. 46th Annual Design Automation Conf., p.83-86. [doi:10.1145/1629911.1629935]
- Beiu, V., Quintana, J.M., Avedillo, M.J., 2003. VLSI implementations of threshold logic—a comprehensive survey. *IEEE Trans. Neur. Netw.*, **14**(5):1217-1243. [doi:10.1109/TNN.2003.816365]
- Chen, K.J., Akeyoshi, T., Maezawa, K., 1995. Monostable-bistable transition logic elements (MOBILEs) based on monolithic integration of resonant tunneling diodes and FETs. *Jpn. J. Appl. Phys.*, **34**(2B):1199-1203. [doi:10.1143/JJAP.34.1199]
- Chen, X., Hurst, S.L., 1981. A consideration of the minimum number of input terminals on universal logic gates and their realization. *Int. J. Electron.*, **50**(1):1-13. [doi:10.1080/00207218108901215]
- Hurst, S.L., 1978. *The Logical Processing of Digital Signals*. Crane Russak & Co., USA.
- Hurst, S.L., Muzio, J.C., Miller, D.M., 1985. *Spectral Techniques in Digital Logic*. Academic Press, USA.
- Kodandapani, K.L., Setlur, R.V., 1997. A note on minimal Reed-Muller canonical forms of switching functions. *IEEE Trans. Comput.*, **C-26**(3):310-313. [doi:10.1109/TC.1977.1674830]
- Lechner, R.J., 1971. Harmonic analysis of switching functions. In: Mukhopadhyay, A. (Ed.), *Recent Developments in Switching Theory*. Academic Press, USA, p.121-228.
- Lee, J., Choi, S., Yang, K., 2010. A new low-power RTD-based 4:1 multiplexer IC using an InP RTD/HBT MMIC technology. Proc. Int. Conf. on Indium Phosphide & Related Materials, p.1-3. [doi:10.1109/ICIPRM.2010.5516385]
- Likharev, K.K., 2008. Hybrid CMOS/nanoelectronic circuits: opportunities and challenges. *J. Nanoelectron. Optoelectron.*, **3**(3):203-230. [doi:10.1166/jno.2008.301]
- Mazumder, P., Kulkarni, S., Bhattacharya, M., et al., 1998. Digital circuit applications of resonant tunneling devices. *Proc. IEEE*, **86**(4):664-686. [doi:10.1109/5.663544]
- Mirhoseini, S.M., Sharifi, M.J., Bahrepour, D., 2010. New RTD-based general threshold gate topologies and application to three-input XOR logic gates. *J. Electr. Comput. Eng.*, **2010**, Article 16. [doi:10.1155/2010/463925]
- Muramatsu, N., Okazaki, H., Waho, T., 2005. A novel oscillation circuit using a resonant-tunneling diode. Proc. IEEE Int. Symp. on Circuits and Systems, p.2341-2344. [doi:10.1109/ISCAS.2005.1465094]
- Muroga, S., 1971. *Threshold Logic and Its Application*. John Wiley & Sons, USA.
- Nikodem, M., Bawiec, M.A., 2010. Logic circuit synthesis using threshold gates based on nanodevices with negative differential resistance property. Proc. 10th IEEE Conf. on Nanotechnology, p.227-232. [doi:10.1109/NANO.2010.5697745]
- Wei, Y., Shen, J.Z., 2011. Novel universal threshold logic gate based on RTD and its application. *Microelectron. J.*, **42**(6):851-854. [doi:10.1016/j.mejo.2011.04.005]
- Wu, X., Hurst, S.L., 1981. A new universal logic gate (ULG3) based on the Reed-Muller canonic expansion. *Int. J. Electron.*, **51**(6):747-762. [doi:10.1080/00207218108901380]
- Zhang, R., Gupta, P., Zhong, L., et al., 2005. Threshold network synthesis and optimization and its application to nanotechnologies. *IEEE Trans. Comput.-Aided Des. Integr. Circ. Syst.*, **24**(1):107-118. [doi:10.1109/TCAD.2004.839468]
- Zheng, Y.X., Huang, C., 2009. Complete logic functionality of reconfigurable RTD circuit elements. *IEEE Trans. Nanotechnol.*, **8**(5):631-642. [doi:10.1109/TNANO.2009.2016563]