



Review:

Enhancing power transfer capability through flexible AC transmission system devices: a review*

Fadi M. ALBATSH^{†1}, Saad MEKHILEF^{†‡1}, Shameem AHMAD¹, H. MOKHLIS², M. A. HASSAN³

⁽¹⁾Power Electronics and Renewable Energy Research Laboratory (PEARL), Department of Electrical Engineering, University of Malaya, Kuala Lumpur 50603, Malaysia)

⁽²⁾Department of Electrical Engineering, Faculty of Engineering, University of Malaya, Kuala Lumpur 50603, Malaysia)

⁽³⁾Department of Engineering Design and Manufacture, University of Malaya, Kuala Lumpur 50603, Malaysia)

[†]E-mail: fbatsh83@yahoo.com; saad@um.edu.my

Received Jan. 14, 2015; Revision accepted May 15, 2015; Crosschecked July 14, 2015

Abstract: Global demand for power has significantly increased, but power generation and transmission capacities have not increased proportionally with this demand. As a result, power consumers suffer from various problems, such as voltage and frequency instability and power quality issues. To overcome these problems, the capacity for available power transfer of a transmission network should be enhanced. Researchers worldwide have addressed this issue by using flexible AC transmission system (FACTS) devices. We have conducted a comprehensive review of how FACTS controllers are used to enhance the available transfer capability (ATC) and power transfer capability (PTC) of power system networks. This review includes a discussion of the classification of different FACTS devices according to different factors. The popularity and applications of these devices are discussed together with relevant statistics. The operating principles of six major FACTS devices and their application in increasing ATC and PTC are also presented. Finally, we evaluate the performance of FACTS devices in ATC and PTC improvement with respect to different control algorithms.

Key words: FACTS devices, Available transfer capability, Power transfer capability, Artificial intelligence

doi:10.1631/FITEE.1500019

Document code: A

CLC number: TM73

1 Introduction

Power generation capacity has not kept pace with consumer demand for power. This demand can be met by building new power generation stations and transmission lines. However, the construction of new transmission systems is hindered by many factors, such as ecological considerations, financial difficulties, and unavailability of space in overpopulated areas (Ahmad *et al.*, 2014a; Albatsh *et al.*, 2015b).

Instead of building a new power system network, the total power transfer capability (PTC) of an existing transmission network could be enhanced. Enhancing PTC can also improve the available transfer capability (ATC), on which the restructuring of power systems is usually based. These improvements also provide an economical business solution to the deregulated power market (Ren *et al.*, 2009; Pandey and Chaitanya, 2012; Ahmad *et al.*, 2014b).

ATC is the measurement of the transfer capability that remains in the transmission system network for further commercial use. Given that restructuring power systems is based completely on ATC, system operators and planners use ATC to determine the capability and strength of the transmission system. These properties are evaluated to estimate the total transfer capability (TTC), transmission reliability

[‡] Corresponding author

* Project supported by the Ministry of Higher Education of Malaysia and University of Malaya under the E-Science Fund Research Grant (No. SF005-2013) and the UMRG Project RP015D-13AET

ORCID: Fadi M. ALBATSH, <http://orcid.org/0000-0002-2999-9458>

© Zhejiang University and Springer-Verlag Berlin Heidelberg 2015

margin (TRM), and capacity benefit margin (CBM) (Khaburi and Haghifam, 2010). Thus, ATC can be expressed mathematically as Ou and Singh (2002).

We have the following equation: $ATC = TTC - TRM - \text{existing transmission commitments (including CBM)}$. ATC can be a very dynamic quantity because it is a function of variable and interdependent parameters which depend on network conditions. Thus, the accurate calculation of ATC relies heavily on the completeness and correctness of available network data.

Enhancing ATC requires extensive control over power flow in an interconnected system. It also requires measuring effective stability progress by using the features of transmission lines to achieve an economical solution. Flexible AC transmission systems (FACTSs) are devices that meet these requirements. Various FACTS devices are used to control dynamically the bus voltages, line impedance, and phase angle of heating, ventilation, and air conditioning (HVAC) transmission lines, thereby enabling them to operate near their thermal capacity (Ahmad *et al.*, 2014d; Albatsh *et al.*, 2015a) and increasing transmission capacity. Given the significance of FACTS devices, many researchers are investigating how they can be used to enhance ATC (Hamoud, 2000; Hingorani and Gyugyi, 2000; Abido, 2009; Manikandan *et al.*, 2011).

Two types of FACTS controllers are available, one based on thyristor-controlled switches and the other on voltage source converters (VSCs) (Section 2). Given that VSCs offer reactive power compensation and control the flow of active power, VSC-based FACTS controllers have been used widely to enhance the ATC and PTC of congested transmission (Jiang *et al.*, 2008). These controllers are used mainly to provide shunt or series compensation. The exact location, number, and parameter settings of FACTS controllers are based on the optimal performance of these devices in enhancing ATC and reducing real power losses (Chansareewittaya and Jirapong, 2012). Many efficient heuristic techniques have been used to solve complex optimization problems. These techniques include the genetic algorithm (GA) (Goldberg and Holland, 1988; Leung and Chung, 2000; Gerbex *et al.*, 2001; Panda and Padhy, 2008; Gitizadeh and Kalantar, 2009), particle swarm optimization (PSO) (Eberhart and Kennedy, 1995; Kennedy and Eberhart, 1995; Eberhart and Shi, 2001;

Moraglio *et al.*, 2007), the bees algorithm (Idris *et al.*, 2009a; Yousefi-Talouki *et al.*, 2010; Naidu *et al.*, 2014), evolutionary programming (EP) (Yang *et al.*, 1996; Yuryevich and Wong, 1999), tabu search (TS), and simulated annealing (SA) (Burke *et al.*, 1999; Bhasaputra and Ongsakul, 2002; Ongsakul and Bhasaputra, 2002; Chansareewittaya and Jirapong, 2012). Conventional methods such as AC load flow and performance index based methods have also been used for optimization. All these methods for improving ATC and PTC are presented in different sections of this review.

In this paper, an overview of FACTS devices and their classification is presented. The six major FACTS devices and their effects on improving ATC and PTC are discussed, based on various controller techniques. In addition, a critical analysis of the performance of these controllers is presented.

2 Overview of FACTS

2.1 Introduction

FACTS stands for the ‘flexible AC transmission system’ (IEEE). FACTSs are “alternating current transmission systems incorporating power electronics based and other static controllers to enhance controllability and PTC of transmission lines” (Ramey and Henderson, 2007). In the late 1980s, the Electric Power Research Institute (EPRI) in the USA conducted the first study of FACTS to maintain the flexibility and stability of power systems by employing electronic power controllers. That study was presented at IEEE meetings, forums, and workshops, and at the international conference organized by EPRI in Cincinnati, Ohio, USA in September, 1990 (Spee and Zhu, 1992; Asare *et al.*, 1994). The concept of FACTS controllers was clearly discussed by Hingorani (1993) and Hingorani and Gyugyi (2000). FACTS devices control power flow through a transmission network by obeying the command of the control center. These devices also facilitate the operation of transmission lines closer to their maximum thermal limits and the control over the line impedances of a transmission system, the voltage magnitude, and the phase angle of buses.

2.2 Types of FACTS

The two types of FACTS controllers based on power electronics are (1) reactors and capacitors

this survey covers articles only from 1990 to 2012, for convenience. The articles were divided into four groups according to their year of publication: 1990–1994, 1995–1999, 2000–2004, 2005–2009, and 2010–2012. This survey covers almost all publications on the use of FACTS in power systems. The survey results are summarized in Fig. 2. Since the 2000s, FACTS applications have significantly increased. VSC-based FACTSs have also become more popular than thyristor-controlled switches. SVC and STATCOM are the most widely used first- and second-generation FACTS controllers, respectively. Both generations have been applied to different areas in power system studies, including optimal power flow (Gyugyi *et al.*, 1995; Ge and Chung, 1999; Li *et al.*, 2000; Zhang and Handschin, 2001; Venkatesh *et al.*, 2004), economic power dispatch, voltage stability (El-Sadek *et al.*, 1997; Haque, 2004), power system security (Visakha *et al.*, 2004), and power quality (Sun *et al.*, 2002; Sannino *et al.*, 2003). Fig. 3 illustrates the use of FACTS controllers along with increasing interest in their ability to enhance ATC.

2.4 Practical applications of FACTS

Manufacturers of FACTS devices are searching for ways to increase reliability under contingency conditions, reduce cost, enhance system stability, and improve power quality. The potential of FACTS devices for these purposes has been widely known since 1979 (Zhang *et al.*, 2012). The first commercialized SVC used to enhance power quality was installed by GE in 1974 (Acharya *et al.*, 2005).

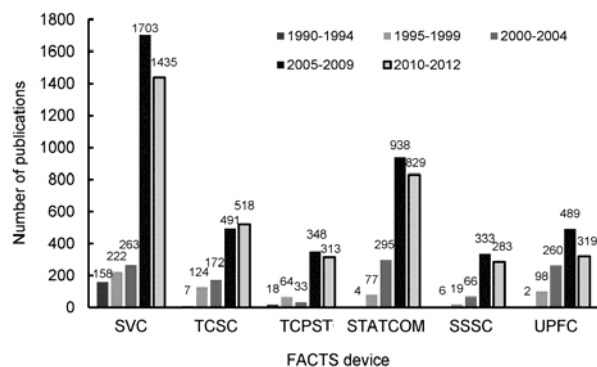

Fig. 2 Number of publications on FACTS applications from 1990 to 2012

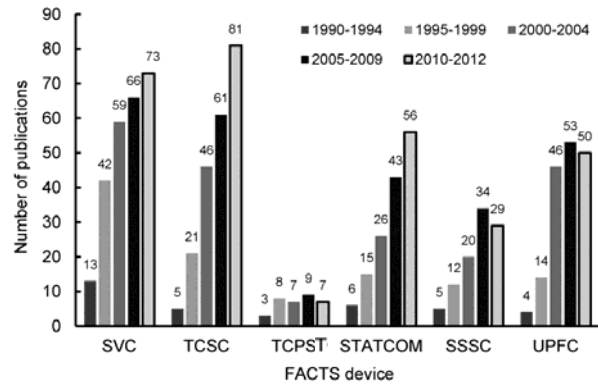

Fig. 3 Number of publications on enhancement of ATC using FACTS devices from 1990 to 2012

SVCs have been installed in about 100 places to control voltage by reactive compensation (Ren *et al.*, 2009) and have been found to enhance ATC and PTC remarkably well. Around 13 SVC projects in 10 countries have been implemented by Siemens. SVC projects were initiated in Canada and France in 2011, and in Saudi Arabia in 2012. The total capacity of installations is higher than 30000 Mvar, which provides good client support and global experience (Siemens, 2012). Since 2002, Cascade Steel (McMinnville, Oregon, USA) has been operating an ABB SVC in its electric arc furnace based melt shop (ABB, 2012). China set up an SVC in the South Hebei Power Grid to enhance power quality. SVCs also provide voltage stability in the transmission network (Tang *et al.*, 2010). ABB has installed FACTS devices in railways to ensure voltage stability, avoid sagging and fluctuating voltage, and improve power quality in the railway network and in surrounding networks (ABB, 2012). SVC has also been used at the An-ding traction substation of the Beijing–Shanghai Electrified Railway to enhance power quality (Ma *et al.*, 2009).

The second most widely used FACTS device is TCSC. The first TCSC, installed by ABB at a substation in Kayenta, Arizona, USA in 1992, increased ATC by 30% (Acharya *et al.*, 2005). TCSC installations can be found in Stöde, Sweden, at the Slatt substation of the Bonneville Power Administration (USA), and at the Kayenta substation of the Western Area Power Administration (USA) (Bachmann *et al.*, 2002; Paserba, 2003). In 1999, ABB installed two TCSC banks in the Brazilian North–South Interconnection (Gama *et al.*, 2000). A TCSC was installed at

the SC station in Stöde, Sweden, to offset subsynchronous resonance (SSR); the TCSC significantly mitigated the SSR problem (Holmberg *et al.*, 1998).

The first commercial STATCOM (± 80 MV·A, 154 kV) was installed by Mitsubishi Electric Power Products at its Inuyama substation in Japan in 1991 (Acharya *et al.*, 2005). Major STATCOM projects can be found in the USA at the Sullivan substation in northeastern Tennessee, the Talega substation of San Diego Gas and Electric, the Essex substation of the Vermont Electric Power Company, and the 115 kV Glenbrook substation in Stamford, Connecticut (Ren *et al.*, 2009). In 2011, ABB supplied and commissioned a FACTS with a STATCOM and an SVC for the power transmission system of Transelec in Chile. Austin Energy, the public utility which serves Austin, Texas, USA and surrounding areas, has been operating an ABB-supplied STATCOM in its 138 kV power system since 2005. The STATCOM, which is 80 Mvar inductive to 110 Mvar capacitive, replaced the oil- and gas-fired Holly Power Plant near downtown Austin, which was constructed in the 1960s (Oskoui *et al.*, 2006).

There have been very few UPFC projects. The first practical UPFC project, consisting of two 160 MV·A voltage source gate turn-off thyristors (GTOs), was constructed in Inez, Kentucky, USA in 1998 (Renz *et al.*, 1999; Paserba, 2003) to control the real power, reactive power flow, and bus voltages of the transmission network. American Electric Power (AEP) applied the 160 MV·A UPFC in the Inez area because of the critical need to increase power transfer capability and provide voltage support in that area. Based on a boundary diagram for UPFC capability, the power flow is increased to its maximum real power swing of ± 80 MW and a maximum reactive power swing of $+200/-150$ Mvar. These results proved the capability of UPFC to control real and reactive power flow in transmission lines independently. In addition, the voltage profile has been improved and the power loss reduced significantly in the whole network after installing the 160 MV·A UPFC. Another UPFC project was built in the Kangjin substation in South Korea in 2003 (Han *et al.*, 2004). The research institute of the Korean Electric Power Corporation (KEPCO) found that power demand was increasing every year. As a result, the power network was suffering from voltage

instability and difficulties in power flow through the transmission lines, especially when there was a fault on the surrounding feeders. KEPCO found that UPFC was the best solution to this problem compared with other devices in terms of the system performance and cost of installation. Based on this investigation, KEPCO has designed and implemented an 80 MV·A UPFC project to be integrated with the 154 kV transmission network. UPFC revealed its high performance in controlling the power flow in transmission lines and in dealing with fault cases during under-voltage or overloaded conditions. Table 2 illustrates the FACTS devices made and installed in different countries by ABB, Siemens, and GE, among others.

2.5 Power flow equations for different FACTS devices

The main concept of FACTS devices can be described by the basic power flow equation for transmission networks (Fig. 4). The real power transmitted between buses a and b in the network depends on the voltage at each end, line impedance, and phase angle. The power flow is described as

$$P = \frac{V_a V_b}{X_{ab}} \sin(\delta_a - \delta_b), \quad (1)$$

where V_a and V_b are bus voltages, X_{ab} is the line impedance, and δ_a and δ_b are phase angles.

The parameters of this equation can be controlled easily by using different FACTS devices to enhance power flow. Series FACTS devices, such as TCSC and SSSC, control line impedance X to increase the real power through transmission lines. On the other hand, shunt FACTS devices, such as SVC and STATCOM, regulate bus voltage to control reactive power.

Series–shunt FACTS devices, such as TCPST, modify the phase and magnitude of the injected series voltage, whereas UPFCs control all power flow parameters (i.e., voltage, impedance, and phase angle) to enhance the power flow of the network.

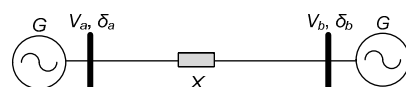

Fig. 4 Single-line diagram of power system parameters

Table 2 Practical implementation of FACTS devices in different countries by renowned companies

FACTS type	Place – Country	Manufacturer	Year
SVC	Nebraska – USA	GE	1974
	Minnesota – USA	Westinghouse	1975
	Milagres – Brazil, Banabuiu – Brazil	Siemens	1983
	Brushy Hill – Canada	Siemens	1986
	Queensland – Australia	ABB	1987
	Kemps Creek I + II – Australia	Siemens	1989
	Kuala Lumpur North substation – Malaysia	ABB	1991
	Eddy County – USA	Siemens	1992
	Harker – UK	Siemens	1993
	Drakelow – UK, Feckenham – UK, Jember – Indonesia	Siemens	1994
	Rejsby Hede – Denmark, Muldersvlei – South Africa	Siemens	1997
	La Pila – Mexico	Siemens	1999
	Funnel – Brazil	Siemens	2001
	Limpio – Paraguay	Siemens	2003
	Siems – Germany	Siemens	2004
	Porter & Ninemile – USA	Siemens	2005
	Devers – USA, Radsted – Denmark, Shinyanga & Iringa – Tanzania, Ahafo – Ghana, Segaliud & Dam Road – Malaysia	Siemens	2006
	National Power Transmission Grid of RTE – France	ABB	2006
	Nopala – Mexico, Sinop – Brazil, Railways & Nebo – Australia, Strathmore – Australia	Siemens	2007
	Alligator Creek – Australia, Islington – New Zealand	Siemens	2009
	London underground stations – UK, Riyadh – Saudi Arabia	ABB	2009
	La Ventosa substation – Mexico	ABB	2010
	Chevire – France, Nanticoke – Canada	Siemens	2011
	Manitoba – Canada	ABB	2011
	Hiteen, Qassim & Afif – Saudi Arabia	Siemens	2012
TCSC	Kayenta, Arizona substation – USA	ABB	1992
	Stöde – Sweden	ABB	1998
	Imperatriz – Brazil	ABB	1999
	Tian Guang – China	Siemens	2003
	Gorakhpur – India	Siemens	2006
STATCOM	Inuyama substation – Japan	Mitsubishi	1991
	Sullivan – USA	Westinghouse	1995
	Rejsby Hede, Vattenfall – Sweden	Siemens	1997
	Laredo, Texas – USA, Virginia – USA	Siemens	2000
	Texas – USA	ABB	2005
	Cerro Navia – Chile	ABB	2011
UPFC	Inez – USA	Westinghouse	1998
	Kanjin – Korea	Siemens	2002

2.5.1 Series compensation

The function of series compensation is to decrease reactive power in transmission lines by controlling line impedance and to increase line voltage to increase line current and real power.

A simple two-bus network with a series capacitor that compensates for the transmission line (Fig. 5) explains the principle behind series compensation. V_a is the sending voltage at bus 1, and V_b is the receiving voltage at bus 2. If V_a and V_b have the same

magnitude with a phase shift δ , Eq. (1) can be rewritten as

$$P = \frac{V^2}{X_{\text{eff}}} \sin \delta, \quad (2)$$

where $X_{\text{eff}} = X_L - X_C$ and $\delta = \delta_a - \delta_b$. Increasing X_C reduces X_{eff} and thus increases the transmitted power. We can present Eq. (2) in terms of voltage on capacitor V_C :

$$P = \frac{V^2}{X_L - V_C / I} \sin \delta, \quad (3)$$

where $X_{\text{eff}} = X_L - V_C / I$ and $V_C = jX_C I$. Eq. (3) confirms that changing capacitor impedance changes the capacitor voltage and thus increases the real power.

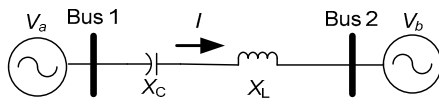

Fig. 5 A two-bus power system with series compensator

2.5.2 Shunt compensation

The equivalent circuit of a shunt compensator can be presented as a controllable voltage source V_{sh} in series with impedance Z_{sh} . In a shunt compensator, reactive power can be adjusted by regulating the output voltage.

Based on the equivalent circuit of a shunt compensator (Fig. 6), if $\vec{V}_{\text{sh}} = |V_{\text{sh}}| \angle \theta_{\text{sh}}$, $\vec{V}_a = |V_a| \angle \theta_a$, the equations of the power flow are

$$P_{\text{sh}} = |V_a|^2 [g_{\text{sh}} - |V_a| |V_{\text{sh}}| [g_{\text{sh}} \cos(\theta_a - \theta_{\text{sh}}) + b_{\text{sh}} \sin(\theta_a - \theta_{\text{sh}})], \quad (4)$$

$$Q_{\text{sh}} = -|V_a|^2 [b_{\text{sh}} - |V_a| |V_{\text{sh}}| [g_{\text{sh}} \sin(\theta_a - \theta_{\text{sh}}) - b_{\text{sh}} \sin(\theta_a - \theta_{\text{sh}})], \quad (5)$$

where $g_{\text{sh}} + jb_{\text{sh}} = 1/Z_{\text{sh}}$. The operating constraint of a shunt compensator for active power exchange can be expressed as

$$P_{\text{EX}} = \text{Re}(V_{\text{sh}} I_{\text{sh}}^*) = 0, \quad (6)$$

where

$$\text{Re}(V_{\text{sh}} I_{\text{sh}}^*) = V_{\text{sh}}^2 g_{\text{sh}} - V_a V_{\text{sh}} [g_{\text{sh}} \cos(\theta_a - \theta_{\text{sh}}) - b_{\text{sh}} \sin(\theta_a - \theta_{\text{sh}})]. \quad (7)$$

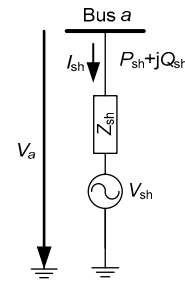

Fig. 6 A single-bus power system with series compensator

3 Static VAR compensator

SVC is a device consisting of any one of the following power electronic devices: thyristor-switched capacitor, thyristor-switched reactor, shunt-switched capacitor, shunt-switched reactor, thyristor-controlled reactor (TCR), and shunt-switched resistor. Compared with conventional switching devices, SVC has a short response time and low maintenance cost (Noroozian *et al.*, 2003). SVCs with thyristor switches achieve a fast response by controlling the firing angle of the thyristor (Ambríz-Pérez *et al.*, 2000; Abdel-Rahman *et al.*, 2006; Padiyar, 2007). Such SVCs can also control transient stability and damp power oscillations. SVC works as a shunt-connected variable reactor or capacitor that compensates for the reactive power required in a transmission network and keeps bus voltage magnitude within its limit. Fig. 7 illustrates the different types of SVC. A three-phase, three-winding transformer is used to connect SVC to the transmission network (Schauder and Mehta, 1993; Noroozian *et al.*, 2003).

Rewatkar and Kewte (2009) investigated the effect of an SVC placed in the middle section of a transmission line. Three vital properties of power (Bollen, 1999; Lin, 2001) were considered, namely, voltage sag (Lamoree *et al.*, 1994), voltage swell (Naidoo and Pillay, 2007), and interruption (Ooi *et al.*, 1997). An SVC with a thyristor-controlled compensator was used to increase the reliability, dynamic stability, and power transmission capability of a power interconnector and reduce congestion over a 69 kV direct grid in conjunction with a high degree of wind power. The SVC of Sahadat *et al.* (2011) significantly increased the PTC of transmission lines and effectively increased the real power and network

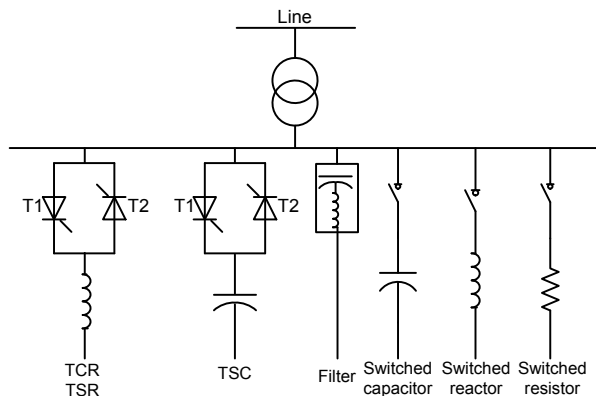

Fig. 7 Configurations of different types of SVC

bus voltage under fault conditions. The effects of SVC on improving transfer capability and controlling line power flow in power systems were analyzed by Komoni *et al.* (2010). The Kosovo power system was examined and developed in PSS/E32. Simulations were conducted for steady-state conditions. A proportional-integral (PI) controller was used as a control tool. SVCs in two typical buses increased the PTC of the power line and the bus voltage.

The feasibility of installing FACTS devices in southeastern Romania was examined by Bulac *et al.* (2009). A steady-state SVC model and an algorithm designed using Power Flow Analysis and Control (PFAC) software were proposed. Static and dynamic analyses of the SVC revealed the improved overall dynamic performance of the power system. Artificial intelligence (AI) methods have been used by many researchers to enhance ATC through optimal placement of FACTS devices. However, the exact location and accurate parameters of FACTS controllers are difficult to determine because of complicated combinatorial optimization (Mori and Goto, 2000). To overcome this problem, Pham *et al.* (2006a; 2006b) proposed the bees algorithm, which was used by Idris *et al.* (2009b) to find an optimal location for the SVC to maximize ATC in a deregulated power system. The proposed algorithm effectively maximized the ATC.

Another AI method, particle swarm optimization (Kennedy and Eberhart, 1995; Venter and Sobieszczanski-Sobieski, 2003; Moraglio *et al.*, 2007), was proposed to solve the multi-objective optimization of minimizing power loss and maximizing TTC with system constraints, such as power bal-

ance, voltage limits, and line thermal limits (Chansareewittaya and Jirapong, 2010; Rao and Kumar, 2011). Constraints were handled by using the penalty function of Parsopoulos and Vrahatis (2002). An SVC with optimal location and rating reduces real power losses and increases TTC compared with a non-SVC case. GA and EP (Yang *et al.*, 1996; Yuryevich and Wong, 1999) were used to determine the optimal location of an SVC discussed by Cai *et al.* (2004) and Ongsakul and Jirapong (2005). Optimally placing an SVC using both algorithms increases TTC significantly. Conventional heuristic methods have high CPU time. To solve this problem, Chansareewittaya and Jirapong (2012) proposed a hybrid model of the TS (Burke *et al.*, 1999; Bhasaputra and Ongsakul, 2002) and SA (van Laarhoven and Aarts, 1987; Goffe *et al.*, 1994) algorithms, TSSA. This hybrid model was used to determine the optimal number, locations, and parameter settings of SVCs in a power system to transfer maximum power and reduce real power loss. TSSA significantly enhances TTC with less CPU time and outperforms EP. Installing FACTS devices enriches both single-area and multi-area ATC. Manikandan *et al.* (2011) analyzed the sustainability and technical advantages of enriching single- and multi-area ATC by using an SVC in a single device and in three multi-type similar and different device combinations. Another optimization tool was used by Madhusudhanarao *et al.* (2010) and Vara Prasad *et al.* (2011) to find the location and control the parameters of an SVC based on a real-code genetic algorithm (RGA) (Xiong *et al.*, 2004; Tsoulos, 2008). Properly installing SVCs improves not only the voltage profile but also the ATC. Nagalakshmi and Kamaraj (2012) used PSO, differential evolution (DE) (Price *et al.*, 2005; Qin *et al.*, 2009), and composite differential evolution (CoDE) (Zheng and Wang, 2011) algorithms to improve the loadability in transmission networks. The performances of PSO, DE, and CoDE were compared to determine their effect on enhancing loadability with SVC. DE is more effective, easier to use, more robust, and exhibits faster convergence and shorter CPU time in enhancing loadability. Using CoDE, a variant of DE, enhances loadability more significantly because it resolves the problem faster than classical DE.

Hybrid mutation particle swarm optimization (HMPSO) (Zhong *et al.*, 2008) for improved ATC

estimation as a decision criterion was proposed by Farahmand *et al.* (2012). HMPSO combines fuzzy logic (Klir and Yuan, 1995; Elsayed *et al.*, 2013; Albatsh *et al.*, 2014) and the analytical hierarchy process (AHP) (Partovi *et al.*, 1990; Handfield *et al.*, 2002) to model the qualification of each problem objective (Saaty, 1977) and prioritize the objectives. It was implemented by using repeated power flow (RPF) (Chiang *et al.*, 1995) with respect to line thermal and voltage stability limits, and was found to be the most promising approach. ATC can be enhanced significantly through prudent use of FACTS devices.

4 Thyristor controlled series compensator

TCSC is a series FACTS controller used to provide series compensation for transmission line impedance in a continuous, swift, and controllable way. TCSC has great potential for increasing ATC through the transmission line. Features such as automatic control of the thyristor have been integrated into TCSC. Therefore, TCSC can be employed to enhance transient stability, mitigate SSR, and damp power oscillations (Perkins and Iravani, 1997; Kakimoto and Phongphananee, 2003; Pilotto *et al.*, 2003; Jovicic and Pillai, 2005). Fig. 8 shows a schematic diagram of a TCSC (Del Rosso *et al.*, 2003), in which a TCR is connected in parallel to a fixed series capacitor.

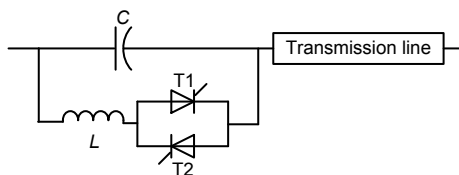

Fig. 8 Block diagram of TCSC

Naik *et al.* (2010) and Srinu Naik *et al.* (2010) used a method based on an Mvar-corrected MW limit to improve ATC by using a TCSC. This method accounted for changes in reactive power flow through the line to calculate ATC. The limit of real power transfer was determined by solving the base cases. ATC was significantly improved.

PTC was enhanced by Yang *et al.* (1996) and Yuryevich and Wong (1999) by selecting an optimal

maximum number of FACTS devices using EP. The same objective was achieved by Chansareewittaya and Jirapong (2011) not only by optimally locating the TCSC, but also by setting its parameters using search space management. Split search space management helped to minimize the operating point interval of the FACTS controller. Using EP and split search space management for TCSC increases the PTC of the system to a promising value. Manikandan (2010) analyzed ATC boosting with a TCSC, and determined the optimal location and parameters of TCSC using PSO and GA. ATC was significantly enhanced by TCSC. The CPU execution time required by PSO to improve ATC was shorter than that required by GA.

An optimization kit which combines GA and RGA (Xiong *et al.*, 2004; Tsoulos, 2008) was used by Vara Prasad *et al.* (2011) to enhance ATC by determining both the optimal location and control parameters of TCSC. RGA effectively determines the optimal location of TCSCs by considering the aim of ATC enhancement. A statistical analysis was conducted by Manohar and Amarnath (2012) to reduce active power losses by implementing a TCSC to enhance ATC. Placing TCSC on the line in a direct and simple way reduces losses and enhances ATC. By minimizing active power losses using a TCSC, Rashed *et al.* (2012) achieved optimum ATC. DE (Price *et al.*, 2005; Qin *et al.*, 2009) and GA were used to determine the optimal location and parameter settings of TCSC.

Khaburi and Haghifam (2010) used a probabilistic analysis to analyze the effect of a TCSC on enhancing TTC. TTC was calculated by employing the RPF method (Chiang *et al.*, 1995). The performance of the proposed algorithm was evaluated against the IEEE Reliability Test System (Subcommittee, 1979). The algorithm robustly enhanced TTC.

GA was used by Alabduljabbar and Milanović (2010) to find the optimal location of a TCSC. The objective functions in this algorithm were based on cost functions, including installation and maintenance cost, the cost of both active and reactive power, and the cost of FACTS devices. The TCSC significantly increased ATC by reducing the generation cost of both real and reactive power. Sensitivity analysis (Saltelli *et al.*, 2000) was implemented by Rashidinejad *et al.* (2008) in steady-state conditions

to enhance ATC with respect to control parameters by using a TCSC. These parameters were optimized through a hybrid heuristic approach of AHP, fuzzy logic (Klir and Yuan, 1995), and RGA. ATC was improved when TCSC was connected to the line.

Farahmand *et al.* (2012) proposed a novel HMPSO method (Zhong *et al.*, 2008) consisting of standard PSO, fuzzy logic, and AHP to enhance ATC using a TCSC. The novel HMPSO method can be employed to significantly enhance ATC by using TCSC precisely. Arzani *et al.* (2008) and Chawla *et al.* (2009) discussed the optimized use of a TCSC to improve ATC. The principle of transmission line reactance compensation was employed to enhance network ATC. Installing a TCSC improved ATC by 15.3%.

Many studies on SVC have also employed a TCSC to enhance ATC using different artificial techniques. Idris *et al.* (2009a; 2009b) and Manikandan *et al.* (2011) determined the optimal locations of both devices using the bees algorithm, while Chansareewittaya and Jirapong (2010) and Nagalakshmi and Kamaraj (2012) used the PSO algorithm to find the optimal location of UPFC. TSSA was used by Chansareewittaya and Jirapong (2012) along with search space management to determine the optimal location and the number of TCSCs, which thus enhances PTC. Nagalakshmi and Kamaraj (2012) proposed to enhance ATC using both DE and CoDE.

5 Thyristor controller phase shifting transformer

TCPST is a FACTS device that can modify the phase angle between bus voltages and the magnitude of series injected variable voltage to enhance power flow. Regulating power flow reduces low-frequency oscillations (Abido, 1999; Hashmani *et al.*, 2001). TCPST can also provide series compensation to increase system stability by speeding up the response of the phase shifter. TCPST can control the frequency positively if it is connected in series with the tie-line (Abraham *et al.*, 2007). TCPST can easily alter the conventional power system stabilizer (PSS) (Wang *et al.*, 1997). The basic construction of a TCPST is as shown in Fig. 9.

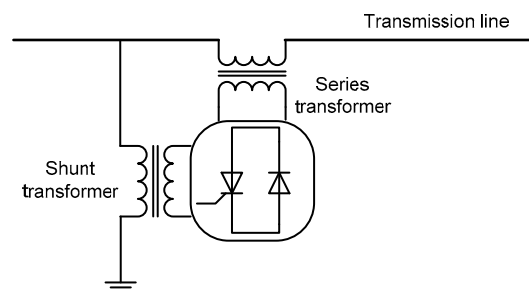

Fig. 9 Block diagram of a TCPST

As a conventional thyristor-switched capacitor/reactor (Paserba, 2003), TCPST is less popular than SVC and TCSC (Fig. 3). Research on this controller for ATC enhancement has been limited. In most studies TCPST was used only for comparison with other controllers. Idris *et al.* (2009b), for instance, used the bees algorithm to find the best location of TCPST, SVC, and TCSC for enhancing ATC. Based on the thermal, voltage, and operational limits of FACTS controllers, the RPF algorithm was used to find the most feasible ATC of a system (Grijalva and Sauer, 1999). The rates of ATC enhancement of all devices were higher with the bees algorithm than with GA. Alabduljabbar and Milanović (2010) placed TCPST optimally in a multi-machine power system to enhance ATC. To perform allocation, optimal power flow and GA-based AI techniques were manipulated. Nagalakshmi and Kamaraj (2012) compared the ability of PSO, DE, and CoDE to enhance the ATC of power systems with TCPST.

6 Static synchronous series compensator

SSSC is an advanced controlled series compensator which functions as a controllable voltage source. It is connected through a transformer in series with a transmission line. SSSC mainly injects voltage with a variable magnitude quadrature with the line current to compensate for voltage drop in the transmission network (Sen, 1998; Zheng *et al.*, 2013). In steady-state operation, SSSC transfers both reactive and real power within the power system network. As SSSC has its own DC capacitor, it does not draw reactive power from the transmission network, which enables it to control active and reactive power and regulate bus voltage. The basic construction of an SSSC is as shown in Fig. 10. Fig. 11 illustrates the

equivalent circuit of SSSC, which combines voltage source V_c , transmission line resistance r , and reactance x_1 . If the DC side has no energy source and the losses of the converter are neglected, the real power in steady-state operation can be expressed as

$$\operatorname{Re}(V_c I^*) = 0, \quad (8)$$

where V_c is in quadrature with I . When V_c lags I by 90° , the operation is capacitive. Thus, the current in the transmission line and therefore the active power are increased. However, when V_c leads I by 90° , the operation is inductive, and the current and active power are reduced.

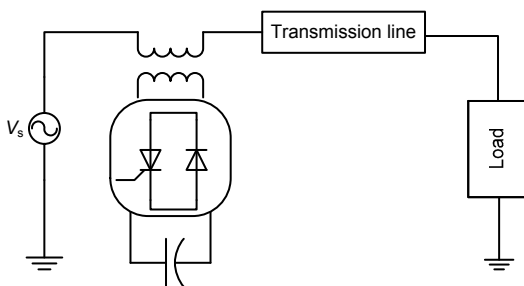

Fig. 10 Basic schematic of an SSSC

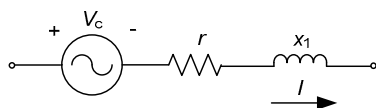

Fig. 11 Equivalent circuit of an SSSC

A series-connected FACTS controller SSSC was used by Nimje *et al.* (2011) to enhance PTC along with the required active and reactive power flow through a transmission line. PTC was enhanced at an injected voltage magnitude of 0.2 p.u. within an angle variation of 0° to 90° .

Zhang and Zhang (2006) used a new power injection SSSC model to analyze power flow. This model includes the complex impedance of the series coupling transformer and the charging susceptance of the line. Because SSSC has multi-control capability, it was used by Iwamoto and Tamura (1981) to enhance ATC, and power flow was calculated using the Newton-Raphson method. To maximize ATC, an exhaustive analysis based on the DC load flow method was presented by Menniti *et al.* (2006) to find the optimal location for an SSSC. Suitable lines for SSSC placement were determined by obtaining a

merit order list with respect to the maximum load increase.

Ajami and Armaghan (2013) used an SSSC to relieve the congestion of transmission lines and thus maximize the ATC between desired network buses. The harmony search (HS) algorithm (Mahdavi *et al.*, 2007) incorporated in a new method was employed to confine the number of lines to speed up convergence. The PSO algorithm was also used for optimization. The results of the HS algorithm were compared with those of the PSO algorithm to determine the effectiveness of the proposed method in locating and sizing optimization problems.

Other studies on SSSC (Esmaili and Esmaili, 2012; Kumar and Kumar, 2013) are discussed in the next two sections along with UPFC and STATCOM.

7 Static synchronous compensator

7.1 Operating principles of STATCOM

A STATCOM is composed of a self-commutated switching power converter, a coupling transformer connected in parallel to the transmission line, and a DC link. The construction of a STATCOM is as illustrated in Fig. 12. STATCOM controls its current magnitude and impedance, and the voltage magnitude of the source and remote bus. It also provides reactive power and controls active power flow, thereby improving the PTC of congested transmission lines (Shakarami and Kazemi, 2010).

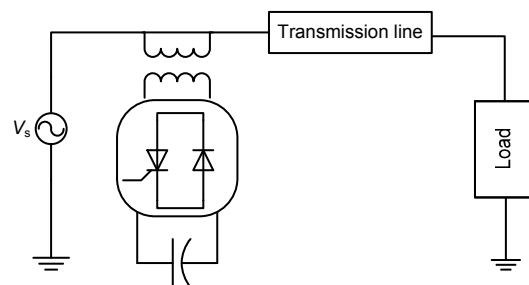

Fig. 12 A two-bus transmission network with STATCOM

The exchange of real power between the transmission network and the STATCOM can be neglected in steady-state analysis. Thus, only reactive power can be exchanged between them (Zhang *et al.*, 2004).

7.2 Enhancing ATC using STATCOM

Power transfer distribution factors (PTDFs)

were used by Kumar and Kumar (2013) and sensitivity analysis by Jain *et al.* (2009) to increase ATC using a STATCOM for bilateral and simultaneous/multi-transaction cases with and without line contingency cases. Both methods provided accurate dynamic ATC values when a STATCOM was connected to the line. Static ATC was slightly increased by optimally placing a STATCOM based on the above methods.

A new control framework using the properties of the single-input two-output feedback system was developed for VSC (Jain *et al.*, 2009). This new control technique enables a STATCOM to adjust active power transfer by using angle control rather than pulse-width modulation (Trzynadlowski *et al.*, 1994; Holmes and Lipo, 2003). The possibility of increasing PTC and controlling line power flow in the Kosovo power system by using a STATCOM was investigated by Komoni *et al.* (2010) through a simulation in PSS/E 32. The results of the simulation showed that using a STATCOM increases PTC and controls line power flow in the power system. Another study used transmission line parameters from the Indore–Itarsi transmission corridor (Chawla *et al.*, 2009) to enhance PTC using a STATCOM and simulated them in the MATLAB Sim Power System. A 48-pulse STATCOM was placed at the center of a transmission system by Singh and Saha (2008) to enhance the PTC of the line. PI controllers were used where system parameters were processed through the d - q axis reference frame. The results of the simulation showed that the PTC of the transmission network was enhanced.

An effective method for sizing and locating a STATCOM to improve TTC was discussed by Esmaili and Esmaili (2012). This method aims to increase TTC, reduce line congestion, and minimize losses for optimization. Optimization was performed using the HS algorithm. The results of the HS algorithm were compared with those of PSO and GA. HS had a better convergence rate and greater accuracy than GA or PSO.

8 Unified power flow controller

UPFC is a versatile FACTS device because it can individually or sequentially control all power system network parameters, including voltage ampli-

tude, line impedance, and phase angle. UPFC consists of a STATCOM and an SSSC connected back to back through a DC link capacitor (Fig. 13). STATCOM is a controllable current source, whereas SSSC acts as a controllable voltage source (Albatsh *et al.*, 2015c). STATCOM is connected to the AC system in parallel through a three-phase transformer and mainly generates the real power to be consumed by SSSC. Moreover, STATCOM supports the transmission network with reactive power compensation. SSSC is also connected to the transmission line via a transformer, but in series. SSSC compensates for voltage drops in the transmission network by injecting an AC voltage with controllable phase and magnitude, thereby improving active and reactive power transmission. Active power can be exchanged between STATCOM and SSSC via the DC link capacitor. Each converter can also exchange reactive power independently at its terminal (Papic *et al.*, 1997; Sen and Stacey, 1998; Huang *et al.*, 2000).

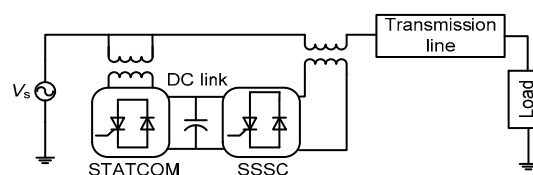

Fig. 13 A schematic diagram of a UPFC

Omoigui *et al.* (2008) analyzed a simplified steady-state model of a multi-terminal UPFC (Fardanesh, 2004; Vasquez-Arnez and Zanetta, 2008) to control both real and reactive power flows through the network. A rotating d - q axis framework controller was used to obtain a time-invariant equation that describes the system. The simulation results confirm that a multi-terminal UPFC is a promising real and reactive power flow controller in transmission lines.

Chengaiyah and Satyanarayana (2012) developed a new steady-state UPFC model with both its shunt and series controllers employed to solve operating constraint violations. The Newton–Raphson method was used to solve the power flow problem. Both voltage and power improved significantly when UPFC was connected to the system.

A method for increasing ATC by using a UPFC was presented by Takasaki (2006) for different power system models. The performance of the UPFC was compared with that of a PSS (Chung *et al.*, 2002;

Hashemi *et al.*, 2012). A combined UPFC and generator PSS was also employed to enhance ATC. This combination significantly enhanced ATC stability.

A comprehensive analysis to improve the PTC of transmission lines using UPFC was presented by Ramesh and Laxmi (2012). A new UPFC control scheme was described for overcoming the limitations of the conventional control scheme, such as the damping of real and reactive power and the attenuation of power fluctuation. Installing UPFC increased PTC and reduced the magnitude of fault current and excitation voltage oscillations.

UPFC and the Sen transformer (ST) were compared by Kumar and Kumar (2012) in terms of enhancing ATC by using an approach based on optimal power flow, for both multi-transaction and bilateral-transaction environments with intact and contingency cases. A model was created to observe the impact of ZIP load (Grigsby, 2012) and compared with the optimal power flow (OPF) model. ATC increased with both UPFC and ST for all transactions in line contingency and intact cases. Some studies have used AI techniques to enhance ATC using UPFC. A PSO-based algorithm was used by Chansareewittaya and Jirapong (2010) and Manikandan *et al.* (2011) to determine the optimal locations, types, and parameter settings of UPFC to enhance PTC and reduce power losses. The results were compared with those of the EP algorithm to determine the efficiency of UPFC.

Esmaili and Esmaili (2012) used HS, which has good convergence and accuracy, to improve TTC and reduce line congestion and total power loss. An AHP was used to obtain the priority vector for each alternative. The performance of the proposed method was compared with those of GA and PSO. Simulation results indicated that the proposed algorithm outperformed the other two algorithms.

The optimal location of FACTS devices, including UPFC, was investigated by Kumar and Kumar (2013) based on the variation pattern of PTDfFs (Sookananta *et al.*, 2007) obtained from the Newton-Raphson load flow approach for bilateral and simultaneous/multi-transaction cases with and without line contingency cases. The FACTS devices enhanced ATC in all transaction cases and line contingencies.

A method for improving transient stability using the UPFC was proposed by Masuta and Yokoyama

(2006). This method involves conducting an OPF to enhance ATC. ATC calculation accounted for both transient and steady-state stability constraints. The OPF problem was formulated to optimize the size of the UPFC inverters. A gain-phase compensation controller, such as a PSS-type, was used by Motoki and Yokoyama (2004) to improve steady-state stability. Transient stability was enhanced by an appropriate tuning of the PI controller parameter (K_p).

Cai *et al.* (2002) discussed the proper installation of a UPFC in a system with parallel transmission lines. UPFC should always be placed on lines with higher impedance because losses in these lines are greater than in other lines. Such an installation increases the total PTC. Sawhney and Jeyasurya (2004) employed a UPFC to increase ATC. The Newton-Raphson load flow method was used to calculate ATC. The results were verified through a continuous power flow program (Shirmohammadi *et al.*, 1988). Power transfer was enhanced by properly allocating UPFC.

A cross-coupled controller was implemented by Basu (2011) and Chansareewittaya and Jirapong (2011) to increase PTC in the transmission line by considering the variation of the power system parameters. The disadvantage of previous methods was that they did not consider the dynamic performance of the DC link capacitor in the implementation of the controllers. Kannan *et al.* (2004) proposed the use of another controller for UPFC based on coordination control of real and reactive powers and considered the dynamics of the DC capacitor.

Fuzzy logic based UPFC has been implemented in PSCAD software to increase PTC in transmission lines (Ahmad *et al.*, 2014c).

9 Critical analysis

Based on this review of major FACTS controllers and their effect on ATC and PTC, we summarize the features of each controller in Table 3. Some remarks about the behavior of different FACTS controllers are also included. Based on this critical analysis, we conclude that research on using $d-q$ transformation, artificial neural networks, and fuzzy logic controllers to increase ATC and PTC has been insufficient. The combination of neural network and the

Table 3 Critical analysis of different FACTS controller on enhancing PTC and ATC

No.	FACTS device	Controller	Feature	Remark	Reference
1	SVC	PI controller	Reduces the steady-state error between the measured and reference signals	Steady-state calculation has been analyzed to show the impact of SVC on power system performance improvement	Komoni <i>et al.</i> , 2010
		BEE	Finds the optimal solution of the power system parameters and can be used in nonlinear integer optimization	The bees algorithm has a remarkable robustness in terms of speed of optimization and accuracy, which helps to maximize the ATC	Idris <i>et al.</i> , 2009b; 2010
		PSO	Increases real power and reduces CPU time	Optimal placement of SVC using PSO has resulted in a reduction in real power losses and enhanced the power transfer capability	Chansareewittaya and Jirapong, 2010; Rao and Kumar, 2011 Cai <i>et al.</i> , 2004
		GA, RGA, and EP	Incremental improvement in PTC, improves voltage profile and ATC with high CPU time	The GA, RGA, and EP algorithms have been used to determine the optimal location of SVC, which enhances the power system performance	
		TSSA	Requires less CPU time and performs better than GA and EP algorithms	SVC based hybrid TSSA increases the power transfer capability of the power system network	Chansareewittaya and Jirapong, 2012
		DE	DE is more effective than PSO and CoDE, is easy to use, has fast convergence capability, and takes less CPU time	DE is a robust algorithm with accurate assessment for increasing loadability in transmission systems with SVC	Nagalakshmi and Kamaraj, 2012
		HMPSO	Improves the estimation of ATC with respect to line thermal and voltage stability limits	HMPSO has been used to determine the best location of SVC, which results in ATC improvement	Farahmand <i>et al.</i> , 2012
2	TCSC	GA and RGA	Used to determine the optimal placement, the controlling parameter, and settings of TCSC but with high CPU time	The results proved that ATC has been maximized and the voltage profile improved with TCSC based GA and RGA algorithms	Alabduljabbar and Milanovic, 2010; Vara Prasad <i>et al.</i> , 2011
		EP	Efficient and reliable algorithm for solving the optimal power flow (OPF) problem, thereby improving ATC	Provides robust power system operations; consequently, the accurate operating state can be determined	Yang <i>et al.</i> , 1996; Yuryevich and Wong, 1999
		PSO	Has potential to enhance ATC with minimum execution time	PSO based TCSC can boost the power transfer capability, thereby improving transmission services of the electricity market	Manikandan, 2010
		DE	Places TCSC in the transmission line such that minimum system losses would be obtained with optimum ATC	The DE algorithm based TCSC has been helpful for finding the optimal location of TCSC, which minimizes the power losses and increases ATC in the transmission network	Rashed <i>et al.</i> , 2012
		Hybrid heuristic approach of AHP, fuzzy logic, and RGA TSSA	Finds the optimal location of TCSC with lower investment cost and better ATC enhancement compared to PSO, GA, EP, and DE algorithms Performs better than PSO, DE, and CoDE in improving ATC	The proposed method based TCSC offers a significant increase in ATC and system flexibility and decrease in environmental impacts and cost TSSA based TCSC improved the total transfer capability and ATC	Rashidinejad <i>et al.</i> , 2008 Chansareewittaya and Jirapong, 2012
3	TCPST	BEE	Uses less CPU time compared to GA. Also, the percentage of ATC enhancement with the bees algorithm is higher than that with GA	The bees optimization algorithm based allocation of TCPST resulted in enhanced ATC of the power network	Idris <i>et al.</i> , 2009b
		PSO, DE, and CoDE	Optimizes ATC considering the thermal limit, voltage and operational limits of TCPST	The DE algorithm proved more effective and accurate with less computation time for increasing the loadability in transmission networks compared with PSO and CoDE	Nagalakshmi and Kamaraj, 2012
4	SSSC	Maximum load increase (MLI)	Multi-control capability in solving the problem of ATC enhancement	Based on the MLI concept, the best location of SSSC is determined, which increases ATC up to the maximum limit	Menniti <i>et al.</i> , 2006
		HS	This algorithm has better optimization capability in terms of locating and sizing SSSC than PSO	HS algorithm based placement of SSSC helps to improve ATC, which in turn reduces the expansion cost of the transmission network	Mahdavi <i>et al.</i> , 2007

To be continued

Table 3

No.	FACTS device	Controller	Feature	Remark	Reference
5	STATCOM	PTDF and sensitivity analysis	Provides accurate values of the dynamic ATC	ATC has been improved after the placement of STATCOM using the method described	Jain <i>et al.</i> , 2009; Kumar and Kumar, 2013
		GTO-VSCs topology with the PI controller	Used to obtain higher voltage gain in the mid-point of the transmission line	Power transfer capability has been increased by 10% in a 132 kV double circuit line	Singh and Saha, 2008
		HS	Increases TTC and minimizes losses with a better convergence rate and greater accuracy than PSO and GA	HS algorithm based STATCOM exhibited high performance in terms of allocation and sizing of STATCOM under normal and contingency operating conditions	Esmaeili and Esmaeili, 2012
6	UPFC	<i>d-q</i> transformation technique	Reduces the three AC quantities to two DC quantities, and finds the reference signals of the UPFC controller with less computation	The results showed that the power capacity of UPFC and the transmission line are important limiting factors to be considered in practical implementation of a transmission network	Omoigui <i>et al.</i> , 2008
		PSO, EP	Determines the optimal locations, and parameter settings of UPFC. PSO is more efficient than EP in terms of accuracy	The proposed algorithms have significantly boosted ATC in single- and multi-area. Power transfer capability has also increased	Chansareewittaya and Jirapong, 2010; Manikandan <i>et al.</i> , 2011
		AHP	Outperforms other algorithms such as PSO, EP, and GA in terms of efficiency and CPU time	AHP algorithm based UPFC has had a significant impact on increasing PTC, decreasing line congestion, and reducing power losses in transmission networks	Esmaeili and Esmaeili, 2012
		PTDF	Provides accurate dynamic ATC values	The results obtained showed that ATC has been increased in normal and line contingency cases when UPFC is connected to the network	Sookananta <i>et al.</i> , 2007; Kumar and Kumar, 2013
		Cross-coupled controller	Increases PTC in the transmission line by considering the variation of the power system parameters	The disadvantage of this method is that it does not consider the dynamic performance of the DC link capacitor	Basu, 2011; Chansareewittaya and Jirapong, 2011
		Coordination control	The control of real and reactive powers in the transmission line	In this control method, the dynamics of the DC capacitor has been taken into consideration	Kannan <i>et al.</i> , 2004

fuzzy expert systems (i.e., neuro-fuzzy systems) has good potential for enhancing ATC by using different FACTS controllers. Moreover, several studies have focused on the steady-state model of FACTS devices. All these techniques, however, have adopted steady-state analysis of the FACTS controller, which is effective only for the planning and designing stage of power system networks. These models cannot be used to study real-time operation of power system networks. Therefore, it is essential to develop a dynamic model of FACTS devices so that the real-time analysis of power system networks can be conducted.

10 Conclusions

We have presented an overview of FACTS devices and their classification, and reviewed studies of

their applications and their use in enhancing ATC (from 1990 to 2012). The applications of FACTS devices in different countries by reputable companies, such as ABB and Siemens, were also reported.

The six major FACTS controllers and their basic structures and effects on enhancing ATC and PTC were examined. A critical analysis of various control techniques for the main FACTS controllers was tabulated to show their performance in improving ATC and PTC.

This survey will be helpful to researchers of ATC and PTC enhancement through the use of FACTS controllers.

References

ABB, 2012. Flexible Alternating Current Transmission Systems (FACTS). Available from <http://www.abb.com/FACTS>.

- Abdel-Rahman, M.H., Youssef, F.M.H., Saber, A.A., 2006. New static var compensator control strategy and coordination with under-load tap changer. *IEEE Trans. Power Deliv.*, **21**(3):1630-1635. [doi:10.1109/TPWRD.2005.858814]
- Abido, M.A., 1999. Thyristor controlled phase shifter based stabilizer design using simulated annealing algorithm. Proc. Int. Conf. on Electric Power Engineering, p.307-312. [doi:10.1109/PTC.1999.826739]
- Abido, M.A., 2009. Power system stability enhancement using FACTS controllers: a review. *Arab. J. Sci. Eng.*, **34**(1B):153-172.
- Abraham, R.J., Das, D., Patra, A., 2007. Effect of TCPS on oscillations in tie-power and area frequencies in an interconnected hydrothermal power system. *IET Gener. Transm. Distr.*, **1**(4):632-639. [doi:10.1049/iet-gtd:20060361]
- Acha, E., Fuerte-Esquivel, C.R., Ambríz-Pérez, H., et al., 2004. FACTS: Modelling and Simulation in Power Networks. Wiley, UK.
- Acharya, N., Sode-Yome, A., Mithulanathan, N., 2005. Facts about flexible AC transmission systems (FACTS) controllers: practical installations and benefits. Proc. Australasian Universities Power Engineering Conf., p.533-538.
- Ahmad, S., Albatsh, F.M., Mekhilef, S., et al., 2014a. A placement method of fuzzy based unified power flow controller to enhance voltage stability margin. Proc. 16th European Conf. on Power Electronics and Applications, p.1-10. [doi:10.1109/EPE.2014.6910863]
- Ahmad, S., Albatsh, F.M., Mekhilef, S., et al., 2014b. An approach to improve active power flow capability by using dynamic unified power flow controller. Proc. IEEE Innovative Smart Grid Technologies-Asia, p.249-254. [doi:10.1109/ISGT-Asia.2014.6873798]
- Ahmad, S., Albatsh, F.M., Mekhilef, S., et al., 2014c. Fuzzy based controller for dynamic unified power flow controller to enhance power transfer capability. *Energy Conv. Manag.*, **79**:652-665. [doi:10.1016/j.enconman.2013.12.042]
- Ahmad, S., Mekhilef, S., Albatsh, F.M., 2014d. Voltage stability improvement by placing unified power flow controller (UPFC) at suitable location in power system network. Proc. Saudi Arabia Smart Grid Conf., p.1-8.
- Ajami, A., Armaghan, M., 2013. A comparative study in power oscillation damping by STATCOM and SSSC based on the multiobjective PSO algorithm. *Turk. J. Electr. Eng. Comput. Sci.*, **21**:213-224. [doi:10.3906/elk-1106-5]
- Alabduljabbar, A.A., Milanović, J.V., 2010. Assessment of techno-economic contribution of FACTS devices to power system operation. *Electr. Power Syst. Res.*, **80**(10):1247-1255. [doi:10.1016/j.epsr.2010.04.008]
- Albatsh, F., 2009. Multirate Ripple-Free Deadbeat Control. MS Thesis, Department of Electrical Engineering, Islamic University of Gaza, Gaza, Palestine.
- Albatsh, F.M., Ahmad, S., Mekhilef, S., et al., 2014. D-Q model of fuzzy based UPFC to control power flow in transmission network. Proc. 7th IET Int. Conf. on Power Electronics, Machines and Drives, p.1-6. [doi:10.1049/cp.2014.0397]
- Albatsh, F.M., Ahmad, S., Mekhilef, S., et al., 2015a. Dynamic power flow control for transmission lines using D-Q fuzzy based unified power flow controller. *Appl. Math. Inform. Sci.*, **9**(12):1-15.
- Albatsh, F.M., Ahmad, S., Mekhilef, S., et al., 2015b. Optimal placement of unified power flow controllers to improve dynamic voltage stability using power system variable based voltage stability indices. *PLoS One*, **10**(4):1-32. [doi:10.1371/journal.pone.0123802]
- Albatsh, F.M., Ahmad, S., Mekhilef, S., et al., 2015c. Power quality improvement in transmission network using fuzzy logic based unified power flow controller. Proc. IEEE Int. Conf. on Industrial Technology, p.1-6.
- Ambríz-Pérez, H., Acha, E., Fuerte-Esquivel, C.R., 2000. Advanced SVC models for Newton-Raphson load flow and Newton optimal power flow studies. *IEEE Trans. Power Syst.*, **15**(1):129-136. [doi:10.1109/59.852111]
- Arzani, A., Jazaeri, M., Alinejad-Beromi, Y., 2008. Available transfer capability enhancement using series FACTS devices in a designed multi-machine power system. Proc. 43rd Int. Universities Power Engineering Conf., p.1-6. [doi:10.1109/UPEC.2008.4651434]
- Asare, P., Diez, T., Galli, A., et al., 1994. An Overview of Flexible AC Transmission Systems. Technical Report, Department of Electrical and Computer Engineering, Purdue University, USA.
- Babu, A.V.N., Sivanagaraju, S., 2012. Assessment of available transfer capability for power system network with multi-line FACTS device. *Int. J. Electr. Eng.*, **5**(1):71-78.
- Bachmann, U., Berger, F., Reinisch, R., et al., 2002. Possibilities of multifunctional FACTS application in the European electric power system under the changing conditions of the liberalized electricity market. CIGRE Session, Germany.
- Basu, M., 2011. Multi-objective optimal power flow with FACTS devices. *Energy Conv. Manag.*, **52**(2):903-910. [doi:10.1016/j.enconman.2010.08.017]
- Bhasaputra, P., Ongsakul, W., 2002. Optimal power flow with multi-type of FACTS devices by hybrid TS/SA approach. Proc. IEEE Int. Conf. on Industrial Technology, **1**:285-290. [doi:10.1109/ICIT.2002.1189908]
- Bollen, M.H., 1999. Understanding Power Quality Problems: Voltage Sags and Interruptions. Wiley-IEEE Press, New York, USA.
- Bulac, C., Diaconu, C., Eremia, M., et al., 2009. Power transfer capacity enhancement using SVC. Proc. IEEE Bucharest PowerTech, p.1-5. [doi:10.1109/PTC.2009.5281833]
- Burke, E., de Causmaecker, P., Berghe, G.V., 1999. A hybrid tabu search algorithm for the nurse rostering problem.

- Proc. 2nd Asia-Pacific Conf. on Simulated Evolution and Learning, p.187-194. [doi:10.1007/3-540-48873-1_25]
- Cai, H., Qu, Z., Gan, D., 2002. Determination of the power transfer capacity of a UPFC with consideration of the system and equipment constraints and of installation locations. *IEE Proc.-Gener. Transm. Distr.*, **149**(1):114-120. [doi:10.1049/ip-gtd:20020002]
- Cai, L.J., Erlich, I., Stamtzis, G., 2004. Optimal choice and allocation of FACTS devices in deregulated electricity market using genetic algorithms. Proc. IEEE Power Systems Conf. and Exposition, p.201-207. [doi:10.1109/PSCE.2004.1397562]
- Chansareewittaya, S., Jirapong, P., 2010. Power transfer capability enhancement with multitype FACTS controllers using particle swarm optimization. Proc. IEEE Region 10 Conf., p.42-47. [doi:10.1109/tencon.2010.5685893]
- Chansareewittaya, S., Jirapong, P., 2011. Power transfer capability enhancement with optimal maximum number of FACTS controllers using evolutionary programming. Proc. 37th Annual Conf. on IEEE Industrial Electronics Society, p.4733-4738. [doi:10.1109/iecon.2011.6119996]
- Chansareewittaya, S., Jirapong, P., 2012. Total transfer capability enhancement with optimal number of FACTS controllers using hybrid TSSA. Proc. IEEE Southeastcon, p.1-7. [doi:10.1109/SECon.2012.6197079]
- Chawla, S., Garg, S., Ahuja, B., 2009. Optimal location of series-shunt FACTS device for transmission line compensation. Proc. Int. Conf. on Control, Automation, Communication and Energy Conservation, p.1-6.
- Chengaiyah, C., Satyanarayana, R.V.S., 2012. Power flow assessment in transmission lines using Simulink model with UPFC. Proc. Int. Conf. on Computing, Electronics and Electrical Technologies, p.151-155. [doi:10.1109/ICCEET.2012.6203778]
- Chiang, H.D., Flueck, A.J., Shah, K.S., et al., 1995. CPFLOW: a practical tool for tracing power system steady-state stationary behavior due to load and generation variations. *IEEE Trans. Power Syst.*, **10**(2): 623-634. [doi:10.1109/59.387897]
- Chung, C.Y., Wang, K.W., Tse, C.T., et al., 2002. Power-system stabilizer (PSS) design by probabilistic sensitivity indexes (PSIs). *IEEE Trans. Power Syst.*, **17**(3):688-693. [doi:10.1109/TPWRS.2002.800914]
- Del Rosso, A.D., Canizares, C.A., Dona, V.M., 2003. A study of TCSC controller design for power system stability improvement. *IEEE Trans. Power Syst.*, **18**:1487-1496.
- Eberhart, R., Kennedy, J., 1995. A new optimizer using particle swarm theory. Proc. 6th Int. Symp. on Micro Machine and Human Science, p.39-43.
- Eberhart, R.C., Shi, Y., 2001. Particle swarm optimization: developments, applications and resources. Proc. Congress on Evolutionary Computation, p.81-86. [doi:10.1109/CEC.2001.934374]
- El-Sadek, M.Z., Dessouky, M.M., Mahmoud, G.A., et al., 1997. Enhancement of steady-state voltage stability by static VAR compensators. *Electr. Power Syst. Res.*, **43**(3):179-185. [doi:10.1016/S0378-7796(97)01179-6]
- Elsayed, B.A., Hassan, M.A., Mekhilef, S., 2013. Decoupled third-order fuzzy sliding model control for cart-inverted pendulum system. *Appl. Math. Inform. Sci.*, **7**(1):193-201.
- Esmaeili, A., Esmaeili, S., 2012. A new multiobjective optimal allocation of multitype FACTS devices for total transfer capability enhancement and improving line congestion using the harmony search algorithm. *Turk. J. Electr. Eng. Comput. Sci.*, **21**:957-979. [doi:10.3906/elk-1108-66]
- Farahmand, H., Rashidinejad, M., Mousavi, A., et al., 2012. Hybrid mutation particle swarm optimisation method for available transfer capability enhancement. *Int. J. Electr. Power Energy Syst.*, **42**(1):240-249. [doi:10.1016/j.ijepes.2012.04.020]
- Fardanesh, B., 2004. Optimal utilization, sizing, and steady-state performance comparison of multiconverter VSC-based FACTS controllers. *IEEE Trans. Power Deliv.*, **19**(3):1321-1327. [doi:10.1109/TPWRD.2004.829154]
- Gama, C., Ångquist, L., Ingeström, G., et al., 2000. Commissioning and operative experience of TCSC for damping power oscillation in the Brazilian north-south interconnection. Proc. CIGRE Session, Paper 14-104.
- Ge, S.Y., Chung, T.S., 1999. Optimal active power flow incorporating power flow control needs in flexible AC transmission systems. *IEEE Trans. Power Syst.*, **14**(2): 738-744. [doi:10.1109/59.761906]
- Gerbex, S., Cherkaoui, R., Germond, A.J., 2001. Optimal location of multi-type FACTS devices in a power system by means of genetic algorithms. *IEEE Trans. Power Syst.*, **16**(3):537-544. [doi:10.1109/59.932292]
- Gitizadeh, M., Kalantar, M., 2009. Optimum allocation of FACTS devices in FARS regional electric network using genetic algorithm based goal attainment. *J. Zhejiang Univ.-Sci. A*, **10**(4):478-487. [doi:10.1631/jzus.A0820130]
- Goffe, W.L., Ferrier, G.D., Rogers, J., 1994. Global optimization of statistical functions with simulated annealing. *J. Econom.*, **60**(1-2):65-99. [doi:10.1016/0304-4076(94)90038-8]
- Goldberg, D.E., Holland, J.H., 1988. Genetic algorithms and machine learning. *Mach. Learn.*, **3**(2-3):95-99. [doi:10.1023/A:1022602019183]
- Grigsby, L.L., 2012. Power System Stability and Control (3rd Ed.). CRC Press, USA.
- Grijalva, S., Sauer, P.W., 1999. Reactive power considerations in linear ATC computation. Proc. 32nd Annual Hawaii Int. Conf. on Systems Sciences, p.327-340. [doi:10.1109/HICSS.1999.772870]
- Gyugyi, L., Schauder, C.D., Williams, S.L., et al., 1995. The unified power flow controller: a new approach to power transmission control. *IEEE Trans. Power Deliv.*, **10**(2): 1085-1097. [doi:10.1109/61.400878]
- Hamoud, G., 2000. Assessment of available transfer

- capability of transmission systems. *IEEE Trans. Power Syst.*, **15**(1):27-32. [doi:10.1109/59.852097]
- Han, Y.S., Suh, I.Y., Kim, J.M., et al., 2004. Commissioning and testing of the KangJin UPFC in Korea. Proc. CIGRE Session.
- Handfield, R., Walton, S.V., Sroufe, R., et al., 2002. Applying environmental criteria to supplier assessment: a study in the application of the analytical hierarchy process. *Eur. J. Oper. Res.*, **141**(1):70-87. [doi:10.1016/S0377-2217(01)00261-2]
- Haque, M.H., 2004. Power flow control and voltage stability limit: regulating transformer versus UPFC. *IEE Proc.-Gener. Transm. Distrib.*, **151**(3):299-304. [doi:10.1049/ip-gtd:20040379]
- Hashemi, Y., Kazemzadeh, R., Azizian, M.R., et al., 2012. Improving power system dynamic performance using attuned design of dual-input PSS and UPFC PSD controller. *Front. Electr. Electron. Eng.*, **7**(4):416-426. [doi:10.1007/s11460-012-0219-6]
- Hashmani, A.A., Wang, Y., Lie, T.T., 2001. Design and application of a nonlinear coordinated excitation and TCPS controller in power systems. Proc. American Control Conf., p.811-816. [doi:10.1109/ACC.2001.945815]
- Hingorani, N.G., 1993. Flexible AC transmission. *IEEE Spect.*, **30**(4):40-45. [doi:10.1109/6.206621]
- Hingorani, N.G., Gyugyi, L., 1999. Understanding FACTS: Concept and Technology of Flexible AC Transmission Systems. Wiley-IEEE Press, New York, USA.
- Holmberg, D., Danielsson, M., Halvarsson, P., et al., 1998. The stode thyristor controlled series capacitor. Proc. CIGRE Session.
- Holmes, D.G., Lipo, T.A., 2003. Pulse Width Modulation for Power Converters: Principles and Practice. Wiley-IEEE Press, USA.
- Huang, Z., Ni, Y., Shen, C., et al., 2000. Application of unified power flow controller in interconnected power systems—modeling, interface, control strategy, and case study. *IEEE Trans. Power Syst.*, **15**(2):817-824. [doi:10.1109/59.867179]
- Idris, R.M., Khairuddin, A., Mustafa, M.W., 2009a. Optimal allocation of FACTS devices for ATC enhancement using bees algorithm. *Int. Scholarly Sci. Res. Innov.*, **3**(6):257-264.
- Idris, R.M., Kharuddin, A., Mustafa, M.W., 2009b. Optimal choice of FACTS devices for ATC enhancement using bees algorithm. Proc. Australasian Universities Power Engineering Conf., p.1-6.
- Idris, R.M., Khairuddin, A., Mustafa, M.W., 2010. Optimal allocation of FACTS devices in deregulated electricity market using bees algorithm. *WSEAS Trans. Power Syst.*, **5**(2):108-119.
- Islam, M., Mekhilef, S., Albatsh, F.M., 2014. An improved transformerless grid connected photovoltaic inverter with common mode leakage current elimination. Proc. 7th Int. Conf. on Power Electronics, Machines and Drives, p.1-6. [doi:10.1049/cp.2014.0296]
- Iwamoto, S., Tamura, Y., 1981. A load flow calculation method for ill-conditioned power systems. *IEEE Trans. Power App. Syst.*, **PAS-100**(4):1736-1743. [doi:10.1109/TPAS.1981.316511]
- Jain, T., Singh, S.N., Srivastava, S.C., 2009. Dynamic ATC enhancement through optimal placement of FACTS controllers. *Electr. Power Syst. Res.*, **79**(11):1473-1482. [doi:10.1016/j.epr.2009.04.019]
- Jiang, X., Fang, X., Chow, J.H., et al., 2008. A novel approach for modeling voltage-sourced converter-based FACTS controllers. *IEEE Trans. Power Deliv.*, **23**(4):2591-2598. [doi:10.1109/TPWRD.2008.923535]
- Jovcic, D., Pillai, G.N., 2005. Analytical modeling of TCSC dynamics. *IEEE Trans. Power Deliv.*, **20**:1097-1104.
- Kakimoto, N., Phongphanphanee, A., 2003. Subsynchronous resonance damping control of thyristor-controlled series capacitor. *IEEE Trans. Power Deliv.*, **18**:1051-1059.
- Kannan, S., Jayaram, S., Salama, M.M.A., 2004. Real and reactive power coordination for a unified power flow controller. *IEEE Trans. Power Syst.*, **19**(3):1454-1461. [doi:10.1109/TPWRS.2004.831690]
- Kennedy, J., Eberhart, R., 1995. Particle swarm optimization. Proc. IEEE Int. Conf. on Neural Networks, p.1942-1948.
- Khaburi, M.A., Haghifam, M.R., 2010. A probabilistic modeling based approach for total transfer capability enhancement using FACTS devices. *Int. J. Electr. Power Energy Syst.*, **32**(1):12-16. [doi:10.1016/j.ijepes.2009.06.015]
- Klir, G.J., Yuan, B., 1995. Fuzzy Sets and Fuzzy Logic: Theory and Applications. Vol. 4. Prentice Hall, New Jersey, USA.
- Komoni, V., Krasniqi, I., Kabashi, G., et al., 2010. Increase power transfer capability and controlling line power flow in power system installed the FACTS. Proc. 7th Mediterranean Conf. and Exhibition on Power Generation, Transmission, Distribution and Energy Conversion, p.1-6. [doi:10.1049/cp.2010.0920]
- Kumar, A., Kumar, J., 2012. Comparison of UPFC and SEN transformer for ATC enhancement in restructured electricity markets. *Int. J. Electr. Power Energy Syst.*, **41**(1):96-104. [doi:10.1016/j.ijepes.2012.03.019]
- Kumar, A., Kumar, J., 2013. ATC determination with FACTS devices using PTDFs approach for multi-transactions in competitive electricity markets. *Int. J. Electr. Power Energy Syst.*, **44**(1):308-317. [doi:10.1016/j.ijepes.2012.07.050]
- Lamoree, J., Mueller, D., Vinett, P., et al., 1994. Voltage sag analysis case studies. *IEEE Trans. Ind. Appl.*, **30**(4):1083-1089.
- Leung, H.C., Chung, T.S., 2000. Optimal power flow with a versatile FACTS controller by genetic algorithm approach. Proc. 5th Int. Conf. on Advances in Power System Control, Operation and Management, p.178-183. [doi:10.1049/cp:20000387]
- Li, N., Xu, Y., Chen, H., 2000. FACTS-based power flow

- control in interconnected power system. *IEEE Trans. Power Syst.*, **15**(1):257-262. [doi:10.1109/59.852130]
- Lin, H.X., 2001. Main problems of modern power quality. *Power Syst. Technol.*, **25**(10):5-12 (in Chinese).
- Ma, J.Z., Wu, M.L., Yang, S.B., 2009. The application of SVC for the power quality control of electric railways. Proc. Int. Conf. on Sustainable Power Generation and Supply, p.1-4. [doi:10.1109/SUPERGEN.2009.5347939]
- Madhusudhanarao, G., Ramarao, P.V., Kumar, T.J., 2010. Optimal location of TCSC and SVC for enhancement of ATC in a de-regulated environment using RGA. Proc. IEEE Int. Conf. on Computational Intelligence and Computing Research, p.1-6. [doi:10.1109/ICCIC.2010.5705874]
- Mahdavi, M., Fesanghary, M., Damangir, E., 2007. An improved harmony search algorithm for solving optimization problems. *Appl. Math. Comput.*, **188**(2): 1567-1579. [doi:10.1016/j.amc.2006.11.033]
- Manikandan, B., 2010. Enhancement of Available Transfer Capability with FACTS Device in the Competitive Power Market. Available from <http://www.scirp.org/Journal/PaperInformation.aspx?paperID=1834>.
- Manikandan, B.V., Raja, S.C., Venkatesh, P., 2011. Available transfer capability enhancement with FACTS devices in the deregulated electricity market. *J. Electr. Eng. Technol.*, **6**(1):14-24.
- Manohar, J.N., Amarnath, J., 2012. Statistical analysis of power system on enhancement of available transfer capability-applying FACTS. *Int. J. Multidiscip. Sci. Eng.*, **3**(7):33-37.
- Masuta, T., Yokoyama, A., 2006. ATC enhancement considering transient stability based on optimal power flow control by UPFC. Proc. Int. Conf. on Power System Technology, p.1-6. [doi:10.1109/ICPST.2006.321766]
- Menniti, D., Scordino, N., Sorrentino, N., 2006. A new method for SSSC optimal location to improve power system available transfer capability. Proc. IEEE PES Power Systems Conf. and Exposition, p.938-945. [doi:10.1109/PSCE.2006.296439]
- Moraglio, A., di Chio, C., Poli, R., 2007. Geometric particle swarm optimisation. Proc. 10th European Conf. on Genetic Programming, p.125-136. [doi:10.1007/978-3-540-71605-1_12]
- Mori, H., Goto, Y., 2000. A parallel tabu search based method for determining optimal allocation of FACTS in power systems. Proc. Int. Conf. on Power System Technology, p.1077-1082. [doi:10.1109/ICPST.2000.897170]
- Motoki, H., Yokoyama, A., 2004. Study on optimal power flow control for ATC enhancement by UPFC and its performance evaluation. Proc. Annual Conf. of Power & Energy Society.
- Nagalakshmi, S., Kamaraj, N., 2012. Comparison of computational intelligence algorithms for loadability enhancement of restructured power system with FACTS devices. *Swarm Evol. Comput.*, **5**:17-27. [doi:10.1016/j.swevo.2012.02.002]
- Naidoo, R., Pillay, P., 2007. A new method of voltage sag and swell detection. *IEEE Trans. Power Deliv.*, **22**(2):1056-1063. [doi:10.1109/TPWRD.2007.893185]
- Naidu, K., Mokhlis, H., Bakar, A.H.A., 2014. Multiobjective optimization using weighted sum artificial bee colony algorithm for load frequency control. *Int. J. Electr. Power Energy Syst.*, **55**:657-667. [doi:10.1016/j.ijepes.2013.10.022]
- Naik, R.S., Vaisakh, K., Anand, K., 2010. Application of TCSC for enhancement of ATC with PTDF in power transmission system. Proc. Int. Conf. on Intelligent and Advanced Systems, p.1-6. [doi:10.1109/icias.2010.5716152]
- Nimje, A.A., Panigrahi, C.K., Mohanty, A.K., 2011. Enhanced power transfer capability by using SSSC. *J. Mech. Eng. Res.*, **3**(2):48-56.
- Noroozian, M., Petersson, N.A., Thorvaldson, B., et al., 2003. Benefits of SVC and STATCOM for electric utility application. Proc. IEEE PES Transmission and Distribution Conf. and Exposition, p.1143-1150. [doi:10.1109/TDC.2003.1335111]
- Omoigui, M., Ojo, O., Karugaba, S., 2008. Analysis of multi-terminal unified power flow controller for power transfer. Proc. 40th North American Power Symp., p.1-7. [doi:10.1109/naps.2008.5307392]
- Ongsakul, W., Bhasaputra, P., 2002. Optimal power flow with FACTS devices by hybrid TS/SA approach. *Int. J. Electr. Power Energy Syst.*, **24**(10):851-857. [doi:10.1016/S0142-0615(02)00006-6]
- Ongsakul, W., Jirapong, P., 2005. Optimal allocation of FACTS devices to enhance total transfer capability using evolutionary programming. Proc. IEEE Int. Symp. on Circuits and Systems, p.4175-4178. [doi:10.1109/ISCAS.2005.1465551]
- Ooi, B.T., Kazerani, M., Marceau, R., et al., 1997. Mid-point siting of FACTS devices in transmission lines. *IEEE Trans. Power Deliv.*, **12**(4):1717-1722. [doi:10.1109/61.634196]
- Oskoui, A., Mathew, B., Hasler, J., et al., 2006. Holly STATCOM-FACTS to replace critical generation, operational experience. Proc. IEEE PES Transmission and Distribution Conf. and Exhibition, p.1393-1398. [doi:10.1109/TDC.2006.1668723]
- Ou, Y., Singh, C., 2002. Assessment of available transfer capability and margins. *IEEE Trans. Power Syst.*, **17**(2):463-468. [doi:10.1109/TPWRS.2002.1007919]
- Padiyar, K.R., 2007. FACTS Controllers in Power Transmission and Distribution. Motilal UK Books of India, India.
- Panda, S., Padhy, N.P., 2008. Comparison of particle swarm optimization and genetic algorithm for FACTS-based controller design. *Appl. Soft Comput.*, **8**(4):1418-1427. [doi:10.1016/j.asoc.2007.10.009]
- Pandey, R.K., Chaitanya, D.V.S.B., 2012. An effective approach for ATC enhancement with FACTS device—a

- case study. Proc. Int. Conf. on Advances in Power Conversion and Energy Technologies, p.1-6. [doi:10.1109/apcet.2012.6301989]
- Papic, I., Zunko, P., Povh, D., *et al.*, 1997. Basic control of unified power flow controller. *IEEE Trans. Power Syst.*, **12**(4):1734-1739. [doi:10.1109/59.627884]
- Parsopoulos, K.E., Vrahatis, M.N., 2002. Particle swarm optimization method for constrained optimization problems. *Intell. Technol. Theory Appl.*, **76**:214-220.
- Partovi, F.Y., Burton, J., Banerjee, A., 1990. Application of analytical hierarchy process in operations management. *Int. J. Oper. Prod. Manag.*, **10**(3):5-19. [doi:10.1108/01443579010134945]
- Paserba, J.J., 2003. How FACTS controllers-benefit AC transmission systems. Proc. IEEE PES Transmission and Distribution Conf. and Exposition, p.949-956. [doi:10.1109/TDC.2003.1335066]
- Perkins, B.K., Iravani, M.R., 1997. Dynamic modeling of a TCSC with application to SSR analysis. *IEEE Trans. Power Syst.*, **12**:1619-1625.
- Pham, D., Ghanbarzadeh, A., Koc, E., *et al.*, 2006a. The bees algorithm—a novel tool for complex optimisation problems. Proc. 2nd Virtual Int. Conf. on Intelligent Production Machines and Systems, p.454-459.
- Pham, D.T., Soroka, A.J., Ghanbarzadeh, A., *et al.*, 2006b. Optimising neural networks for identification of wood defects using the bees algorithm. Proc. IEEE Int. Conf. on Industrial Informatics, p.1346-1351. [doi:10.1109/INDIN.2006.275855]
- Pilotto, L.A.S., Bianco, A., Long, W.F., *et al.*, 2003. Impact of TCSC control methodologies on subsynchronous oscillations. *IEEE Trans. Power Deliv.*, **18**:243-252.
- Price, K., Storn, R.M., Lampinen, J.A., 2005. *Differential Evolution: a Practical Approach to Global Optimization*. Springer, Germany. [doi:10.1007/3-540-31306-0]
- Qin, A.K., Huang, V.L., Suganthan, P.N., 2009. Differential evolution algorithm with strategy adaptation for global numerical optimization. *IEEE Trans. Evol. Comput.*, **13**(2):398-417. [doi:10.1109/TEVC.2008.927706]
- Ramesh, M., Laxmi, A.J., 2012. Stability of power transmission capability of HVDC system using FACTS controllers. Proc. Int. Conf. on Computer Communication and Informatics, p.1-7. [doi:10.1109/iccci.2012.6158889]
- Ramey, D.G., Henderson, M., 2007. Overview of a special publication on transmission system application requirements for FACTS controllers. Proc. Power Engineering Society General Meeting, p.1-5.
- Rao, K.S., Kumar, B.K., 2011. Placement of SVC for minimizing losses and maximizing total transfer capability using particle swarm optimization. Proc. IET Conf. on Renewable Power Generation, p.1-5. [doi:10.1049/cp.2011.0161]
- Rashed, G.I., Sun, Y., Shaheen, H.I., 2012. Optimal location and parameter setting of TCSC for loss minimization based on differential evolution and genetic algorithm. *Phys. Proced.*, **33**:1864-1878. [doi:10.1016/j.phpro.2012.05.296]
- Rashidinejad, M., Farahmand, H., Fotuhi-Firuzabad, M., *et al.*, 2008. ATC enhancement using TCSC via artificial intelligent techniques. *Electr. Power Syst. Res.*, **78**(1): 11-20. [doi:10.1016/j.epsr.2006.12.005]
- Ren, H., Watts, D., Mi, Z., *et al.*, 2009. A review of FACTS' practical consideration and economic evaluation. Proc. Asia-Pacific Power and Energy Engineering Conf., p.1-5. [doi:10.1109/APPEEC.2009.4918115]
- Renz, B.A., Keri, A., Mehraban, A.S., *et al.*, 1999. AEP unified power flow controller performance. *IEEE Trans. Power Deliv.*, **14**(4):1374-1381. [doi:10.1109/61.796231]
- Rewatkar, S.B., Kewte, S.G., 2009. Role of power electronics based FACTS controller SVC for mitigation of power quality problems. Proc. 2nd Int. Conf. on Emerging Trends in Engineering and Technology, p.731-735. [doi:10.1109/icetet.2009.197]
- Saaty, T.L., 1977. A scaling method for priorities in hierarchical structures. *J. Math. Psychol.*, **15**(3):234-281. [doi:10.1016/0022-2496(77)90033-5]
- Sahadat, M.N., Al Masood, N., Hossain, M.S., *et al.*, 2011. Real power transfer capability enhancement of transmission lines using SVC. Proc. Asia-Pacific Power and Energy Engineering Conf., p.1-4. [doi:10.1109/appeec.2011.5748663]
- Saltelli, A., Chan, K., Scott, E.M., 2000. *Sensitivity Analysis*. Wiley, New York, USA.
- Sannino, A., Svensson, J., Larsson, T., 2003. Power-electronic solutions to power quality problems. *Electr. Power Syst. Res.*, **66**(1):71-82. [doi:10.1016/S0378-7796(03)00073-7]
- Sawhney, H., Jeyasurya, B., 2004. Application of unified power flow controller for available transfer capability enhancement. *Electr. Power Syst. Res.*, **69**(2-3):155-160. [doi:10.1016/j.epsr.2003.07.012]
- Schauder, C., Mehta, H., 1993. Vector analysis and control of advanced static VAR compensators. *IEE Proc. C*, **140**(4):299-306. [doi:10.1049/ip-c.1993.0044]
- Sen, K.K., 1998. SSSC-static synchronous series compensator: theory, modeling, and application. *IEEE Trans. Power Deliv.*, **13**(1):241-246. [doi:10.1109/61.660884]
- Sen, K.K., Stacey, E.J., 1998. UPFC-unified power flow controller: theory, modeling, and applications. *IEEE Trans. Power Deliv.*, **13**(4):1453-1460. [doi:10.1109/61.714629]
- Shakarami, M.R., Kazemi, A., 2010. Robust design of static synchronous series compensator-based stabilizer for damping inter-area oscillations using quadratic mathematical programming. *J. Zhejiang Univ.-Sci. C (Comput. & Electron.)*, **11**(4):296-306. [doi:10.1631/jzus.C0910428]
- Shirmohammadi, D., Hong, H.W., Semlyen, A., *et al.*, 1988. A compensation-based power flow method for weakly meshed distribution and transmission networks. *IEEE Trans. Power Syst.*, **3**(2):753-762.

- Siemens, 2012. Discover the World of FACTS Technology. Available from www.siemens.com/energy/facts.
- Singh, B., Saha, R., 2008. Enhancing power transfer capacity of transmission system by a reduced magnetics based 48-pulse STATCOM controller. Proc. Joint Int. Conf. on Power System Technology and IEEE Power India Conf., p.1-8. [doi:10.1109/icpst.2008.4745288]
- Sood, V.K., 2004. HVDC and FACTS Controllers: Applications of Static Converters in Power Systems. Springer.
- Sookananta, B., Galloway, S.J., Burt, G.M., et al., 2007. Employment of power transfer distribution factor for the optimal placement of FACTS devices. Proc. Int. Power Engineering Conf., p.569-573.
- Spee, R., Zhu, W., 1992. Flexible AC transmission systems simulation and control. Proc. 3rd AFRICON Conf., p.65-68. [doi:10.1109/AFRCON.1992.624419]
- Srinu Naik, R., Vaisakh, K., Anand, K., 2010. Determination of ATC with PTDF using linear methods in presence of TCSC. Proc. 2nd Int. Conf. on Computer and Automation Engineering, p.146-151. [doi:10.1109/iccae.2010.5451495]
- Subcommittee, P.M., 1979. IEEE reliability test system. *IEEE Trans. Power App. Syst.*, **6**:2047-2054.
- Sun, J., Czarkowski, D., Zabar, Z., 2002. Voltage flicker mitigation using PWM-based distribution STATCOM. Proc. IEEE Power Engineering Society Summer Meeting, p.616-621. [doi:10.1109/PESS.2002.1043313]
- Takasaki, M., 2006. Power transfer capability enhancement with UPFC under circumstances of uncertain power flow pattern. Proc. IEEE PES Transmission and Distribution Conf. and Exhibition, p.659-665. [doi:10.1109/tde.2006.1668575]
- Tang, B.F., Fan, H., Wang, X.W., et al., 2010. The dynamic simulation research on application of SVC in the south Hebei power grid. Proc. China Int. Conf. on Electricity Distribution, p.1-4.
- Trzynadlowski, A.M., Blaabjerg, F., Pedersen, J.K., et al., 1994. Random pulse width modulation techniques for converter-fed drive systems—a review. *IEEE Trans. Ind. Appl.*, **30**(5):1166-1175. [doi:10.1109/28.315226]
- Tsoulos, I.G., 2008. Modifications of real code genetic algorithm for global optimization. *Appl. Math. Comput.*, **203**(2):598-607. [doi:10.1016/j.amc.2008.05.005]
- van Laarhoven, P.J., Aarts, E.H., 1987. Simulated Annealing. Springer.
- Vara Prasad, J., Sai Ram, I., Jayababu, B., 2011. Genetically optimized FACTS controllers for available transfer capability enhancement. *Int. J. Comput. Appl.*, **19**(4):23-27.
- Vasquez-Arnez, R.L., Zanetta, L.C., 2008. A novel approach for modeling the steady-state VSC-based multilines FACTS controllers and their operational constraints. *IEEE Trans. Power Deliv.*, **23**(1):457-464. [doi:10.1109/TPWRD.2007.905564]
- Venkatesh, B., George, M.K., Gooi, H.B., 2004. Fuzzy OPF incorporating UPFC. *IEE Proc. C*, **151**(5):625-629. [doi:10.1049/ip-gtd:20040611]
- Venter, G., Sobieszczanski-Sobieski, J., 2003. Particle swarm optimization. *AIAA J.*, **41**(8):1583-1589.
- Visakha, K., Thukaram, D., Jenkins, L., 2004. Application of UPFC for system security improvement under normal and network contingencies. *Electr. Power Syst. Res.*, **70**(1):46-55. [doi:10.1016/j.epr.2003.11.011]
- Wang, H.F., Swift, F.J., Li, M., 1997. Analysis of thyristor-controlled phase shifter applied in damping power system oscillations. *Int. J. Electr. Power Energy Syst.*, **19**(1):1-9. [doi:10.1016/S0142-0615(96)00020-8]
- Watts, D., Ren, H., 2007. FACTS: characteristics, applications and economic value: a literature review. Proc. 7th IASTED Int. Conf. on Power and Energy Systems, p.450-455.
- Xiong, W.Q., Zhang, Y.P., Wei, P., 2004. An improved real-code genetic algorithm. Proc. Int. Conf. on Machine Learning and Cybernetics, p.2361-2364.
- Yang, H.T., Yang, P.C., Huang, C.L., 1996. Evolutionary programming based economic dispatch for units with non-smooth fuel cost functions. *IEEE Trans. Power Syst.*, **11**(1):112-118. [doi:10.1109/59.485992]
- Yousefi-Talouki, A., Gholamian, S.A., Hosseini, M., et al., 2010. Optimal power flow with unified power flow controller using artificial bee colony algorithm. *Int. Rev. Electr. Eng.*, **5**(6):2773-2782.
- Yuryevich, J., Wong, K.P., 1999. Evolutionary programming based optimal power flow algorithm. *IEEE Trans. Power Syst.*, **14**(4):1245-1250. [doi:10.1109/59.801880]
- Zhang, X.P., Handschin, E.J., 2001. Advanced implementation of UPFC in a nonlinear interior-point OPF. *IEE Proc. C*, **148**(5):489-496. [doi:10.1049/ip-gtd:20010476]
- Zhang, X.P., Handschin, E., Yao, M., 2004. Multi-control functional static synchronous compensator (STATCOM) in power system steady-state operations. *Electr. Power Syst. Res.*, **72**(3):269-278. [doi:10.1016/j.epr.2004.04.011]
- Zhang, X.P., Rehtanz, C., Pal, B., 2012. Flexible AC Transmission Systems: Modelling and Control. Springer.
- Zhang, Y.K., Zhang, Y., 2006. A novel power injection model of embedded SSSC with multi-control modes for power flow analysis inclusive of practical constraints. *Electr. Power Syst. Res.*, **76**(5):374-381. [doi:10.1016/j.epr.2005.06.008]
- Zheng, J.G., Wang, X., 2011. Diversity composite differential evolution algorithm for constrained optimization problems. *Comput. Integ. Manuf. Syst.*, **17**(11):2447-2456.
- Zheng, Z., Yang, G., Geng, H., 2013. Coordinated control of a doubly-fed induction generator-based wind farm and a static synchronous compensator for low voltage ride-through grid code compliance during asymmetrical grid faults. *Energies*, **6**(9):4660-4681. [doi:10.3390/en6094660]
- Zhong, W.L., Wang, H.S., Zhang, J., et al., 2008. Novel particle swarm optimization with heuristic mutation. *Comput. Eng. Des.*, **29**(13):3402-3406 (in Chinese).