



Fault evolution-test dependency modeling for mechanical systems*

Xiao-dong TAN^{†1,2}, Jian-lu LUO¹, Qing LI¹, Bing LU¹, Jing QIU²

⁽¹⁾Department of Electronic Technology, Officers College of PAP, Chengdu 610213, China)

⁽²⁾Science and Technology on Integrated Logistics Support Laboratory, National University of Defense Technology, Changsha 410073, China)

[†]E-mail: xdt1010@126.com

Received Jan. 9, 2015; Revision accepted June 15, 2015; Crosschecked Sept. 9, 2015

Abstract: Tracking the process of fault growth in mechanical systems using a range of tests is important to avoid catastrophic failures. So, it is necessary to study the design for testability (DFT). In this paper, to improve the testability performance of mechanical systems for tracking fault growth, a fault evolution-test dependency model (FETDM) is proposed to implement DFT. A testability analysis method that considers fault trackability and predictability is developed to quantify the testability performance of mechanical systems. Results from experiments on a centrifugal pump show that the proposed FETDM and testability analysis method can provide guidance to engineers to improve the testability level of mechanical systems.

Key words: Mechanical systems, Design for testability (DFT), Fault evolution-test dependency model (FETDM)

doi:10.1631/FITEE.1500011

Document code: A

CLC number: TP277

1 Introduction

Mechanical systems have great significance in defence and civil domains. However, functional failures in mechanical systems due to the increasing severity of faults in one or several components are the main cause of heavy casualties and damage. Preventive maintenance (PM) of mechanical systems is very important for the safe, efficient, and reliable operation (Gao *et al.*, 2014). Tracking and monitoring the growth of faults in components in mechanical systems using a large number of tests or sensors before they fail is very important to realize PM functions and reduce losses due to failures (Tan *et al.*, 2013). In actual projects, simply adding test points or sensors is impractical, and will ultimately reduce a system's reliability and increase the monitoring cost. However, if the number of tests is insufficient, the objective of

tracking and monitoring the growth of faults cannot be achieved, and false alarms and missed detections may occur. Therefore, many researchers have shown that the application of the concept of design for testability (DFT) to the development of mechanical systems can significantly improve the level of tracking and monitoring fault growth (Biswas and Mahadevan, 2007).

A testability model is an important component of DFT. Since the middle 1980s, a great number of testability models and computer aided design tools have been developed. Aeronautics Radio Inc. (ARINC) developed the system testability and maintenance program (STAMP) to provide a tool for modeling diagnostic information and assessing system testability (Simpson *et al.*, 1989). The portable interactive trouble-shooter (POINTER) developed to process models from STAMP to POINTER, is an information flow model (Simpson and Balaban, 1982; Simpson *et al.*, 1989). Lin *et al.* (1998) introduced a testability analysis tool called the automatic dependency model analyzer (ADMA) based on dependency models. Detex System Inc. (DSI) developed a

* Project supported by the National Natural Science Foundation of China (No. 61403408)

ORCID: Xiao-dong TAN, <http://orcid.org/0000-0001-5458-7693>
 © Zhejiang University and Springer-Verlag Berlin Heidelberg 2015

diagnostic engineering tool called eXpress based on information flow (Sheppard, 1996). The multi-signal flow graph developed by Deb *et al.* (1995) is another comprehensive method to model cause-effect dependencies in complex systems. Qualtech Systems Inc. (QSI) developed the testability engineering and maintenance system (TEAMS) design tool based on multi-signal flow (Pattipati *et al.*, 1994). Hess *et al.* (2008) introduced a software tool called maintenance aware design environment (MADe) to design, assess, and optimize prognostics and health management (PHM) systems. These tools are widely used for automated test sequencing and testability analysis in industry and government.

Generally, the testability models discussed above are used widely in fault diagnosis of electrical systems due to their modularization and a strong relationship between faults and tests. For example, a short circuit failure of resistance will result directly in an output abnormality of a circuit. Such models can represent fault-test dependency clearly in electrical systems, and can be used for analyzing the ability to detect and isolate faults. However, for mechanical systems, such models based on Boolean relationships between faults and tests cannot correctly describe the dependency between fault growth or evolution and tests. Moreover, fault propagation time and gain are more likely to be affected by fluid or mechanical vibration than in electrical systems.

To overcome these problems, Tan *et al.* (2013) proposed a novel modeling approach called the failure evolution mechanism model for PHM systems. Yang *et al.* (2014) developed a quantified uncertainty hierarchical model (QUHM) by considering equipment health management (EHM) functions in testability. The testability analysis and evaluation for EHM can be realized using a multiple dependency matrix. However, it is difficult to build the matrix correctly for a complex mechanical system. Moreover, Tan *et al.* (2013) and Yang *et al.* (2014) did not consider fault propagation time and gain or quantify the fault trackability of a system to assist in its DFT.

In this study, a novel fault evolution-test dependency model (FETDM) is developed by considering the fault propagation time and gain, time effect and sensitivity of tests for faults. Furthermore, to evaluate the testability level of a pump, we consider external factors for testability analysis besides the

fault detection rate and fault isolation rate, such as the trackability, tracking rate, and prediction rate of failures.

2 Fault evolution-test dependency model

The FETDM should consider two factors: one is the fault propagation time and fault progression, and the other is the time effect and sensitivity of tests for faults. These two factors distinguish this model from traditional testability models.

The FETDM (Fig. 1) consists of MODULE nodes, FAILURE MODE nodes, TEST nodes, and directed lines.

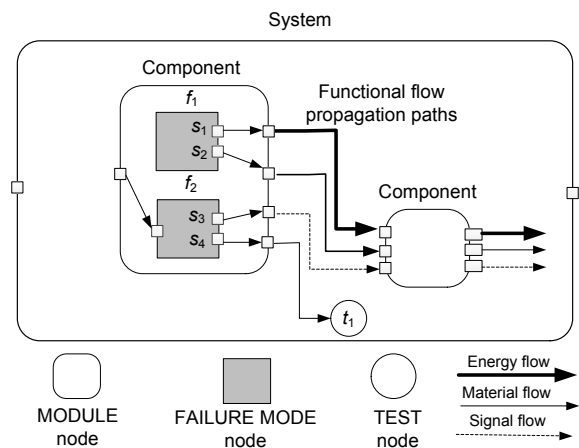

Fig. 1 A schematic of the fault evolution-test dependency model

The MODULE node represents an element or a level of a system, and may have sub-modules or be a sub-module of a larger system. Each MODULE node corresponds to an associated repair level and has the following properties: module name, function, bond group, bond variables, number of inputs and outputs (determined by the materials, energy, or signals), mean time to failure (MTTF), repair and rectification time, and cost.

A FAILURE MODE node represents the failure mode of a unit under test (UUT) in the system and can belong to each MODULE node. The outputs of a FAILURE MODE node represent the failure symptom parameters related to failure evolution. The properties of the node include: failure mode name, failure type, failure rate, severity, condition parameters

related to failures, failure diagnosis, and prognostics methods. At the component level, those symptom parameters related to fault evolution can be obtained through a physical failure model or a physical damage model. For example, the pressure and flow rate can be taken as symptom parameters related to fault evolution of a seal's crack according to the physics of a failure model (Biswas and Mahadevan, 2007). At the system level, the performance parameters indicating the UUT's health can be taken as the fault symptom parameters, and the information can be obtained through expert knowledge and functional attributes (Byington *et al.*, 2004). For example, the frictional damping coefficient, local gear stiffness, torque constant, and motor temperature indicating the health of the electromechanical actuator can be used to describe the fault evolution of gear slipping, bearing seizure, and motor failure.

A TEST node corresponds to a physical or logical location where measurements can be made. Each TEST node is characterized by name, cost, weight, signal-to-noise ratio (SNR), range, response time, environmental constraints, and type of condition parameters.

A directed line represents functional relationships between UUTs, expressed using the functional ontology developed by Stone and Wood (2000). According to the requirements of the functional flow, lines can be classified into three types: material flow, signal flow, and energy flow (Kurtoglu and Tumer, 2008). Each line is characterized by the fault propagation time (FPT) and the fault propagation gain (FPG). The FPT and FPG are defined based on the response of a system to a step input (the step response). The FPT is defined as the rise time when the response reaches 10% of the steady gain, and the FPG is defined as the steady-state gain (Zhang, 2005; Johnson, 2008).

In an FETDM, if a propagation path exists from fault symptom s_j to test t_k , and the propagation gains along the path are $\{PG_{j1}, PG_{j2}, \dots, PG_{jn}\}$, then the FPG of this path can be calculated by multiplying all the FPGs along the path, given by $\prod_{k=1}^n PG_{jk}$. If the propagation times along the path are $\{PT_{j1}, PT_{j2}, \dots, PT_{jn}\}$, then the time-to-detect (TTD) of test t_k for the fault symptom parameter s_j is estimated as the summation of the propagation of the FPT along this path,

given by $\sum_{k=1}^n PT_{jk}$. Therefore, the fault trackability of a test can be calculated by means of FETDM.

3 Testability analysis

3.1 Fault evolution-test dependency

In the fault evolution process of a component from normal state to failure, fault symptoms related to fault progression usually appear before total failure. To track the progression of a fault, fault symptom parameters related to each fault are monitored by means of test points equipped in the system. Fault-symptom (**FS**) and symptom-test (**ST**) matrices are defined to describe the dependency between fault evolution and tests in order to analyze the trackability of the system for its fault evolution process.

FS is the fuzzy connection between failure modes and fault symptoms in a system. It includes the failure symptom information related to fault progression in the fault evolution process. In **FS**, the rows represent failure modes and the columns represent condition parameters related to fault symptoms:

$$\mathbf{FS} = \begin{matrix} & s_1 & s_2 & \cdots & s_N \\ \begin{matrix} f_1 \\ f_2 \\ \vdots \\ f_M \end{matrix} & \begin{bmatrix} \alpha_{11} & \alpha_{12} & \cdots & \alpha_{1N} \\ \alpha_{21} & \alpha_{22} & \cdots & \alpha_{2N} \\ \vdots & \vdots & & \vdots \\ \alpha_{M1} & \alpha_{M2} & \cdots & \alpha_{MN} \end{bmatrix} \end{matrix} \quad (1)$$

In the matrix, α_{ij} ($i=1, 2, \dots, M; j=1, 2, \dots, N$) is 1 if fault f_i causes a symptom s_j to occur, and 0 otherwise. **FS** stands for the relationships between faults and fault symptoms related to each fault progression, and can be used to help engineers monitor or track the fault evolution process through test setting in a system.

ST is the relationship between condition parameters related to fault symptoms and tests in a system and can be derived using the bond graph method (Alabakhshizadeh *et al.*, 2011):

$$\mathbf{ST} = \begin{matrix} & t_1 & t_2 & \cdots & t_K \\ \begin{matrix} s_1 \\ s_2 \\ \vdots \\ s_N \end{matrix} & \begin{bmatrix} \beta_{11} & \beta_{12} & \cdots & \beta_{1K} \\ \beta_{21} & \beta_{22} & \cdots & \beta_{2K} \\ \vdots & \vdots & & \vdots \\ \beta_{N1} & \beta_{N2} & \cdots & \beta_{NK} \end{bmatrix} \end{matrix} \quad (2)$$

In matrix \mathbf{ST} , the rows represent condition parameters related to fault symptoms and the columns represent tests in a system. β_{jk} ($j=1, 2, \dots, N$; $k=1, 2, \dots, K$) is +1, 0, or -1, representing that the response of test t_k increases, fixes, or decreases, respectively, when failure symptom s_i appears. \mathbf{ST} is used to analyze which fault symptoms can be monitored and tracked by the tests of a system. Thus, fault detectability, isolatability, trackability, and predictability can be assessed by integrating \mathbf{FS} .

3.2 Testability analysis

In this paper, the traditional testability components (e.g., fault detection rate (FDR) and fault isolation rate (FIR)) are extended by adding the trackability for the failure evolution process and the predictability for the time to failure. The trackability of pump systems represents the ability to track the development of faults by monitoring fault symptom parameters related to fault progression in their evolution process. The predictability of pump systems is used to evaluate the ability to predict the time-to-failure for each of the critical, competitive failure modes within the system by means of various failure prediction algorithms (Tan et al., 2013). Here, the definitions related to testability analysis are as follows:

1. A finite set of failure modes in a system is $F=\{f_1, f_2, \dots, f_M\}$, where M is the number of failure modes in the system.

2. A finite set of failure symptoms is $S=\{s_1, s_2, \dots, s_N\}$, where N is the number of fault symptoms in the system. This paper defines the mapping of one failure symptom to one condition parameter. The symptom set of failure mode f_i is $S(f_i)=\{s_j|s_j \in S, \alpha_{ij}=1\}$.

3. A finite set of available tests is $T=\{t_1, t_2, \dots, t_K\}$, where K is the number of tests in the system.

4. A finite set of detectable failure symptoms is $S_D=\{s_j|\exists \beta_{jk} \neq 0\}$.

5. A finite set of isolatable failure symptoms is $S_I=\{s_j|s_j \in S_D, \forall j_1 \neq j_2, \mathbf{ST}_{j_1} \oplus \mathbf{ST}_{j_2}=1\}$, where \mathbf{ST}_{j_1} and \mathbf{ST}_{j_2} are the j_1 th and j_2 th row vectors respectively in \mathbf{ST} , $1 \leq j_1, j_2 \leq N$, and \oplus denotes the XOR operation.

6. The failure set which can be detected by the test points in the system is $F_{CD}=\{f_i|f_i \in F, \exists s_j \in S(f_i), \beta_{jk} \neq 0\}$.

7. The failure set which can be isolated by the

system is $F_{CI}=\{f_i|f_i \in F_{CD}, \forall s_j \in S(f_i), \exists s_j \in S_I\}$.

8. The failure set which can be tracked by the system is $F_{CT}=\{f_i|f_i \in F_{CD}, \forall s_j \in S(f_i), \beta_{jk} \neq 0\}$.

9. The failure set which can be predicted by the system is $F_{CP}=\{f_i|f_i \in F_{CD}, \forall s_j \in S(f_i), s_j \in S_I\}$.

10. For the set of redundant tests whose columns have the same values in \mathbf{ST} , $\mathbf{RT}=\{t_k|t_k \in T, \forall k_1 \neq k_2, \mathbf{ST}_{k_1} \oplus \mathbf{ST}_{k_2}=0\}$, where \mathbf{ST}_{k_1} and \mathbf{ST}_{k_2} are the k_1 th and k_2 th column vectors respectively in \mathbf{ST} , and $1 \leq k_1, k_2 \leq K$.

The mathematical calculations of FDR, FIR, fault tracking rate (FTR), and fault prediction rate (FPR) can be obtained by referring to Tan et al. (2013).

The system's ability to track the fault evolution process can be calculated, and the time-to-failure can be predicted by considering the fault propagation time and gain, and the sensitivity of tests to the fault evolution process.

Definition 1 Denote V_{jk} as the detection sensitivity of test t_k for symptom parameter s_j . If the test data can be used to map known measurements to a 'symptom parameter measurement', the detection sensitivity of the test represents the ratio of the change in the symptom parameter measurement to the change in the test measurement, $\Delta t/\Delta s$, where Δt is the change in the test measurement, and Δs is the change in the symptom parameter. For example, let there be three test nodes t_1, t_2 , and t_3 , in the presence of a fault f_1 . The value of fault symptom parameter s_1 changes by 1 unit and the measurement changes for t_1, t_2 , and t_3 are 0.01 unit, 0.02 units, and 0.03 units, respectively. Without considering the resolution of these tests, the detection sensitivity of t_1, t_2 , and t_3 would be 0.01, 0.02, and 0.03, respectively. Obviously, test t_3 is the most sensitive to the fault symptom parameter s_1 of fault f_1 .

Definition 2 Denote \mathbf{TSD}_{jk} as the detectability of test t_k for fault symptom parameter s_j . Here, the fault symptom parameter is a map to 'fault measurement' (Stone and Wood, 2000):

$$\mathbf{TSD}_{jk} = (1 + e^{-10(V_{jk}-0.5)})^{-1} \cdot (1 + e^{-10(\text{SNR}_k-0.5)})^{-1}, \quad (3)$$

where SNR_k is the SNR of test t_k .

Definition 3 Let \mathbf{TFT}_{ik} represent all symptom parameters of fault f_i that can be detected by test t_k . It is used to calculate the trackability for fault f_i of test t_k :

$$TFT_{ik} = \begin{cases} \prod_{j=1}^{|S(f_i)|} TSD_{jk} \left(1 - \frac{TTD_{jk}}{TTF_i}\right)^{0.5} \cdot \frac{SyD_{jk}}{TTF_i}, & TTD_{jk} \leq TTF_i, \\ 0, & TTD_{jk} > TTF_i, \end{cases} \quad (4)$$

where $|S(f_i)|$ is the number of fault symptom parameters in $S(f_i)$, TTD_{jk} is the time-to-detect (TTD) for symptom parameter s_j of test t_k , TTF_i is the time to failure (TTF) for fault f_i , and SyD_{jk} is the symptom duration for symptom parameter s_j of test t_k .

The average trackability (AT) is defined as the mean value of the trackability for all faults in the system:

$$AT = \frac{1}{M} \sum_{i=1}^M \frac{1}{|T(f_i)|} \sum_{k=1}^{|T(f_i)|} TFT_{ik}, \quad (5)$$

where $|T(f_i)|$ is the number of tests in which fault mode f_i can be detected.

4 Case studies

A centrifugal pump is one of the key components in mechanical systems that results in the reduction of a system’s reliability and availability (Kallesøe, 2005). To improve a pump system’s safety, reliability, maintainability, and affordability, and reduce life cycle cost, in this study we take the centrifugal pump as an example to verify the effectiveness of our proposed method. To realize the functions of tracking and monitoring fault growth in the system, we

assume the following testability indices: FDR=100%, FIR>98%, FTR>96%, FPR>94%.

The bond graph model of the pump system is as shown in Fig. 2 and the definitions of the components are listed in Table 1.

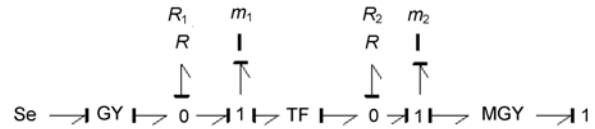

Fig. 2 The system-level bond graph of the centrifugal pump system

Se: effort source; GY: gyrator; TF: transformer; ‘1’: effort junction; ‘0’: flow junction

Combining structural and functional information of the centrifugal pump system, the FETDM of the system level was established using the method introduced in Section 2 (Fig. 3). The drive motor, as a unit in the subsystem level, was modeled (Fig. 4).

At the component level, the physics of a failure model of corrosion/erosion damage to vanes, and of wear and fatigue damage to seals were introduced by Biswas and Mahadevan (2007). Based on that information, the FETDMs of vanes and seals were constructed respectively (Figs. 5 and 6). For simplicity, the other UUT’s FETDMs are not presented here.

In the above FETDMs, the critical failure modes and correlated attributes, the fault symptom parameters related to failure modes, the test set of the pump system, and the attributes of directed lines are listed in Tables 2, 3, 4, and 5, respectively.

By using the multi-signal methodology, the traditional FT matrix can be obtained based on Figs. 3–6 and is listed in Table 6. By means of the testability

Table 1 Definitions of components using bond graph methodology

Component	Input flow	Output flow	Bond type	Variable	Unit
Voltage source	–	Supply current	Voltage source	E	V
Stator	Stator current	Flux	Resistor	R_f	Ω
Rotor	Armature current	Torque	Resistor	R_a	Ω
			Inductor	L_a	mH
Mechanical part	Torque	Speed	Gyrator	M	N·m
Motor	Electrical energy	Mechanical energy	Gyrator	–	–
Shaft and bearing in the motor	Torque, speed	Loss	Resistor	R_1	Ω
Transmission rod, rotor vanes, and gears	Torque, speed	Torque, speed	Inductor	m_1	mH
Dissipation in the coupling	Torque, speed	Loss	Resistor	R_2	Ω
Coupling	Torque, speed	Torque, speed	Inductor	m_2	mH
Pump	Mechanical energy	Hydraulic energy	MGY	–	–

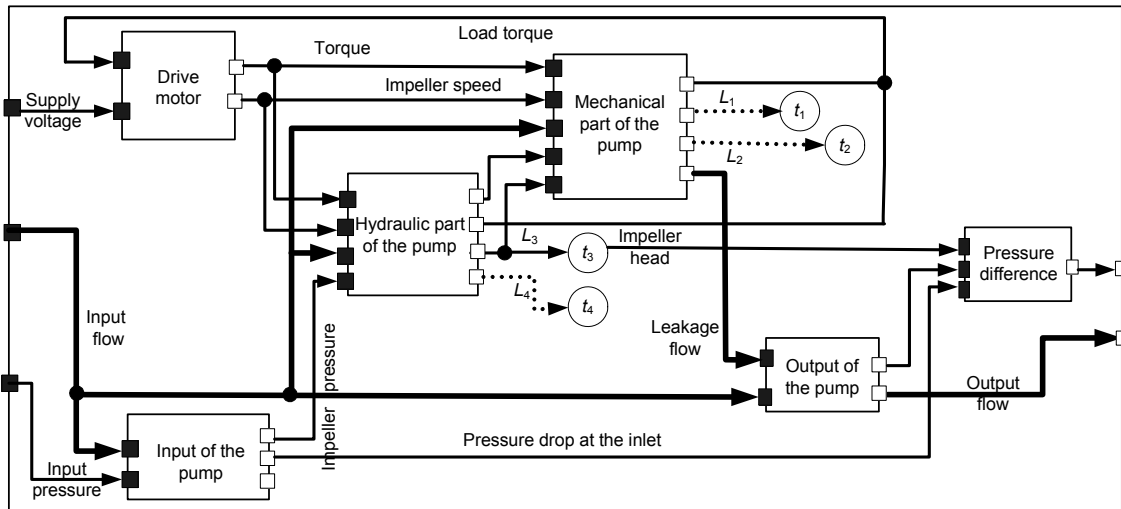

Fig. 3 The FETDM of the centrifugal pump system

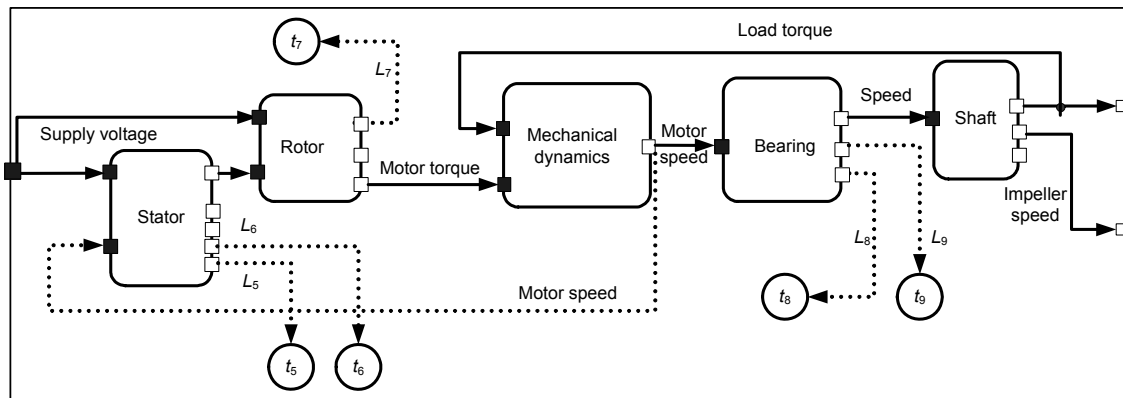

Fig. 4 The FETDM of the drive motor

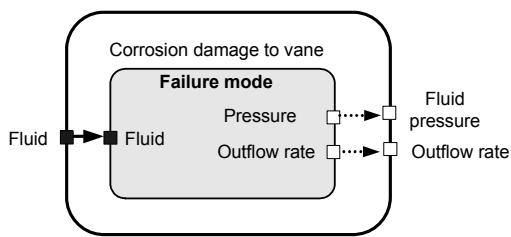

Fig. 5 The FETDM of vanes

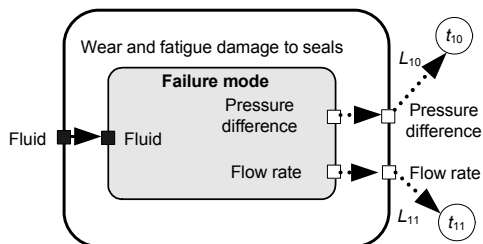

Fig. 6 The FETDM of seals

Table 2 Critical failure modes and correlated attributes

Failure code	Failure mode	Failure rate ($\times 10^{-6}$)
f_1	Low pressure at the inlet of the pump	0.2
f_2	Leakage on the outlet pipe	0.1
f_3	Corrosion/Erosion damage to vane	3.2
f_4	Wear and fatigue damage to seals	2.3
f_5	Wear of the bearings in the pump	1.2
f_6	In-turn short circuits	1.0
f_7	Broken rotor bar	3.5
f_8	Wear of bearing in the motor	4.1
f_9	Wear of shaft in the motor	0.6

analysis method introduced by Pattipati *et al.* (1994), all faults in the fault set $F = \{f_1, f_2, f_3, f_4, f_5, f_6, f_7, f_8, f_9\}$ can be detected by the system. However, $\{f_1, f_2, f_3\}$ is

an ambiguity set, which cannot be isolated. So, the FDR and FIR in the pump system can be calculated by referring to Tan *et al.* (2013) to be 100% and 75.35%, respectively. The results show that the traditional testability indices cannot meet the predetermined requirements.

However, by means of the results of fault evolution analysis and bond graph methodology, matrices

Table 3 Fault symptom parameters related to failure modes

Symptom code	Failure symptom parameter
s_1	Pressure at the inlet
s_2	Flow on the outlet pipe
s_3	Change in pressure
s_4	Outflow rate
s_5	Velocity of the leaking fluid
s_6	Pressure difference between inside and outside pipes
s_7	Mechanical vibration
s_8	Pump bearing temperature
s_9	Stator temperature
s_{10}	Stator current
s_{11}	Rotor temperature
s_{12}	Rotor current
s_{13}	Bearing temperature
s_{14}	Bearing vibration
s_{15}	Shaft current

Table 5 Attributes of directed lines

Code	PG	PT/SyD
L_1	10.00	0.1 ms/TTF
L_2	0.20	1 s/TTF
L_3	0.50	5 ms/TTF
L_4	0.01	0.1 s/TTF
L_5	0.20	2 ms/TTF
L_6	0.50	2 μ s/TTF
L_7	0.20	1 s/TTF
L_8	0.20	1 s/TTF
L_9	10.00	2 μ s/TTF
L_{10}	0.01	0.1 s/TTF
L_{11}	0.50	5 ms/TTF

Table 4 Test set of the pump system

Test code	Test type	Test placement	Function	Cost (\$)	SNR (dB)
t_1	Vibration test	Pump mechanics	Testing pump mechanics vibration	1	15
t_2	Temperature test	Pump mechanics	Testing temperature of pump bearing	1	15
t_3	Pressure test	Hydraulic part	Testing outflow pressure	1	15
t_4	Flow rate test	Hydraulic part	Testing outflow rate	1	15
t_5	Temperature test	Stator	Testing stator temperature	1	15
t_6	Current test	Stator	Testing stator current	1	15
t_7	Temperature test	Rotor	Testing rotor temperature	1	15
t_8	Temperature test	Bearing	Testing bearing temperature	1	15
t_9	Vibration test	Bearing	Testing bearing vibration	1	15
t_{10}	Flow rate test	Seals	Testing leaking flow rate	1	15
t_{11}	Pressure test	Seals	Testing pressure difference	1	15

Table 6 Traditional FT matrix

	t_1	t_2	t_3	t_4	t_5	t_6	t_7	t_8	t_9	t_{10}	t_{11}
f_1	0	0	1	1	0	0	0	0	0	0	0
f_2	0	0	1	1	0	0	0	0	0	0	0
f_3	0	0	1	1	0	0	0	0	0	0	0
f_4	0	0	0	0	0	0	0	0	0	1	1
f_5	1	1	0	0	0	0	0	0	0	0	0
f_6	0	0	0	0	1	1	0	0	0	0	0
f_7	0	0	0	0	1	1	1	0	0	0	1
f_8	0	0	0	0	0	0	0	1	1	0	0
f_9	0	0	0	0	0	1	0	1	1	0	0

Table 7 FS matrix

	s_1	s_2	s_3	s_4	s_5	s_6	s_7	s_8	s_9	s_{10}	s_{11}	s_{12}	s_{13}	s_{14}	s_{15}
f_1	1	0	0	0	0	0	0	0	0	0	0	0	0	0	0
f_2	0	1	0	0	0	0	0	0	0	0	0	0	0	0	0
f_3	0	0	1	1	0	0	0	0	0	0	0	0	0	0	0
f_4	0	0	0	0	1	1	0	0	0	0	0	0	0	0	0
f_5	0	0	0	0	0	0	1	1	0	0	0	0	0	0	0
f_6	0	0	0	0	0	0	0	0	1	1	0	0	0	0	0
f_7	0	0	0	0	0	0	0	0	0	0	1	1	0	0	0
f_8	0	0	0	0	0	0	0	0	0	0	0	0	1	1	0
f_9	0	0	0	0	0	0	0	0	0	1	0	0	0	0	1

Table 8 ST matrix

	t_1	t_2	t_3	t_4	t_5	t_6	t_7	t_8	t_9	t_{10}	t_{11}
s_1	0	0	-1	-1	0	0	0	0	0	0	0
s_2	0	0	-1	-1	0	0	0	0	0	0	0
s_3	0	0	-1	0	0	0	0	0	0	0	0
s_4	0	0	0	-1	0	0	0	0	0	0	0
s_5	0	0	0	0	0	0	0	0	0	0	+1
s_6	0	0	0	0	0	0	0	0	0	+1	0
s_7	+1	0	0	0	0	0	0	0	0	0	0
s_8	0	+1	0	0	0	0	0	0	0	0	0
s_9	0	0	0	0	+1	0	0	0	0	0	0
s_{10}	0	0	0	0	0	+1	0	0	0	0	0
s_{11}	0	0	0	0	0	0	+1	0	0	0	0
s_{12}	0	0	0	0	+1	+1	0	0	0	0	0
s_{13}	0	0	0	0	0	0	0	+1	0	0	0
s_{14}	0	0	0	0	0	0	0	0	+1	0	0
s_{15}	0	0	0	0	0	-1	0	+1	+1	0	0

FS and **ST** (Tables 7 and 8) can be obtained. Based on these two matrices, by using the testability analysis method introduced in Section 3, the fault mode and fault symptom set in the system can be obtained, $F = \{f_1, f_2, f_3, f_4, f_5, f_6, f_7, f_8, f_9\}$, $S = \{s_1, s_2, s_3, s_4, s_5, s_6, s_7, s_8, s_9, s_{10}, s_{11}, s_{12}, s_{13}, s_{14}, s_{15}\}$, and test set $T = \{t_1, t_2, t_3, t_4, t_5, t_6, t_7, t_8, t_9, t_{10}, t_{11}\}$. In Table 7, the fault symptom set of fault f_1 is $s(f_1) = \{s_1\}$. From Table 8, symptom s_1 can be detected by t_3 and t_4 . However, the two rows of s_1 and s_2 represent the same data and form an ambiguity group. So, fault f_1 can be detected, but it cannot be isolated, tracked, or predicted. Similarly, the fault symptom set of fault f_2 is $s(f_2) = \{s_2\}$. Although symptom s_2 can be detected by t_3 and t_4 , the values on rows s_1 and s_2 are the same in Table 8. So, fault f_2 can be detected, but cannot be isolated, tracked, or predicted. The fault symptom set of fault f_3 is $s(f_3) = \{s_3,$

$s_4\}$. In Table 8, symptoms s_3 and s_4 can be detected by t_3 and t_4 , respectively. So, fault mode f_3 can be detected. Because the rows of symptoms s_3 and s_4 represent different data, two fault symptoms s_3 and s_4 of fault model f_3 can be isolated. So, fault f_3 can be detected, isolated, tracked, and predicted. Here, the same principles are taken, $s(f_4) = \{s_5, s_6\}$, $s(f_5) = \{s_7, s_8\}$, $s(f_6) = \{s_9, s_{10}\}$, $s(f_7) = \{s_{11}, s_{12}\}$, $s(f_8) = \{s_{13}, s_{14}\}$, $s(f_9) = \{s_{10}, s_{15}\}$, and fault symptoms $\{s_5, s_6, s_7, s_8, s_9, s_{10}, s_{11}, s_{12}, s_{13}, s_{14}, s_{15}\}$ can be detected and isolated by available tests in the system from Table 8. So, fault set $\{f_4, f_5, f_6, f_7, f_8, f_9\}$ can also be detected, isolated, tracked, and predicted. In conclusion, all faults in F can be detected, the un-detectable failure set (UDF) is empty, the un-isolatable failure set (UIF), un-trackable failure set (UTF), and un-predictable failure set (UPF) are all $\{f_1, f_2\}$. The AT, FDR, FIR, FTR,

FPR can be calculated to be 0.8868, 100%, 98.1%, 98.1%, and 98.1%, respectively.

Finally, the results of testability analysis are listed in Table 9. Obviously, the testability indices meet the predetermined requirements of the pump system. The above results show that the FETDM of the pump system can correctly describe the PHM-related information and that the testability analysis can effectively evaluate the PHM performance level.

Table 9 Results of testability analysis

Analysis content	Value
Number of failure modes	9
Number of tests	11
Number of failure symptom parameters	15
Un-detectable failure (UDF)	\emptyset
Un-isolatable failure (UIF)	$\{f_1, f_2\}$
Un-trackable failure (UTF)	$\{f_1, f_2\}$
Un-predictable failure (UPF)	$\{f_1, f_2\}$
RT	\emptyset
Average trackability (AT)	0.8868
Fault detection rate (FDR)	100%
Fault isolation rate (FIR)	98.1%
Fault tracking rate (FTR)	98.1%
Fault prediction rate (FPR)	98.1%

5 Conclusions

According to the essential requirements of PHM systems for DFT, we propose a novel testability model based on a failure evolution mechanism by considering the fault evolution process and the sensitivity of tests for fault evolution. Besides fault detection and isolation, some new testability indices such as AT, FTR, and FPR are developed to describe the trackability of tests for the fault evolution process and failure predictability, respectively. Thus, a testability analysis method for PHM requirements is put forward. Results of the analysis can help designers optimize the DFT to improve PHM performance. The experimental results show that the FETDM and testability analysis methodology are important for improving the ability to monitor the health of PHM systems and system reliability, and to reduce operating costs.

Future studies will focus on applying FETDM to complex mechanical systems and improving the

technique proposed in this paper for use in other engineering systems. A software tool based on FETDM theory is being developed to realize those functions. Moreover, some methods widely used in health assessment and fault prognostics, such as data-driven methods (e.g., artificial neural networks, hidden Markov model, and support vector machine) and physics of failure (PoF) based methods, will be considered in developing FETDM to provide better support for condition-based maintenance or PHM.

References

- Alabakhshizadeh, A., Iskandarani, Y., Hovland, G., et al., 2011. Analysis, modeling and simulation of mechatronic systems using the Bond Graph method. *Model. Identif. Contr.*, **32**(1):35-45. [doi:10.4173/mic.2011.1.3]
- Biswas, G., Mahadevan, S., 2007. A hierarchical model-based approach to systems health management. *Proc. IEEE Aerospace Conf.*, p.1-14. [doi:10.1109/AERO.2007.352943]
- Byington, C.S., Watson, M., Edwards, D., et al., 2004. A model-based approach to prognostics and health management for flight control actuators. *Proc. IEEE Aerospace Conf.*, p.3551-3562. [doi:10.1109/AERO.2004.1368172]
- Deb, S., Pattipati, K.R., Raghavan, V., et al., 1995. Multi-signal flow graphs: a novel approach for system testability analysis and fault diagnosis. *IEEE Aerosp. Electron. Syst. Mag.*, **10**(5):14-25. [doi:10.1109/62.373993]
- Gao, Y.C., Feng, Y.X., Tan, J.R., 2014. Multi-principle preventive maintenance: a design-oriented scheduling study for mechanical systems. *J. Zhejiang Univ.-Sci. A (Appl. Phys. & Eng.)*, **15**(11):862-872. [doi:10.1631/jzus.A1400102]
- Hess, A., Stecki, J.S., Rudov-Clark, S.D., 2008. The maintenance aware design environment: development of an aerospace PHM software tool. *Proc. Conf. on Prognostics and Health Management*, p.1-9.
- Johnson, J., 2008. Fault Propagation Timing Analysis to Aid in the Selection of Sensors for Health Management Systems. MS Thesis, University of Missouri-Rolla, USA.
- Kallesøe, C., 2005. Fault Detection and Isolation in Centrifugal Pumps. PhD Thesis, Aalborg University, Denmark.
- Kurtoglu, T., Tumer, I.Y., 2008. A graph-based fault identification and propagation framework for functional design of complex system. *J. Mech. Des.*, **130**(5):051401.1-051401.8. [doi:10.1115/1.2885181]
- Lin, C., Hayes, L., Malais, A., et al., 1998. A new dependency model based testability analyzer. *Proc. IEEE Systems Readiness Technology Conf.*, p.187-191. [doi:10.1109/AUTEST.1998.713442]
- Pattipati, K.R., Raghavan, V., Shakeri, M., et al., 1994.

- TEAMS: testability engineering and maintenance system. Proc. American Control Conf., p.1989-1995. [doi:10.1109/ACC.1994.752424]
- Sheppard, J.W., 1996. Maintaining diagnostic truth with information flow models. Proc. IEEE Conf. Record Test Technology and Commercialization, p.447-454. [doi:10.1109/AUTEST.1996.547773]
- Simpson, W.R., Balaban, H.S., 1982. The ARINC research system testability and maintenance program (STAMP). Proc. IEEE AUTOTESTCON Conf., p.88-95.
- Simpson, W.R., Sheppard, J.W., Unkle, C.R., 1989. POINTER—an intelligent maintenance aid. Proc. IEEE Automatic Testing Conf., p.26-31. [doi:10.1109/AUTEST.1989.81094]
- Stone, R.B., Wood, K.L., 2000. Development of a functional basis for design. *J. Mech. Des.*, **122**(4):359-370. [doi:10.1115/1.1289637]
- Tan, X.D., Qiu, J., Liu, G.J., et al., 2013. A novel approach of testability modeling and analysis for PHM systems based on failure evolution mechanism. *Chin. J. Aeronaut.*, **26**(3):766-776. [doi:10.1016/j.cja.2013.04.044]
- Yang, S.M., Qiu, J., Liu, G.J., 2014. Hierarchical model-based approach to testability modeling and analysis for PHM of aerospace systems. *J. Aerosp. Eng.*, **27**(1):131-139. [doi:10.1061/(ASCE)AS.1943-5525.0000203]
- Zhang, G.F., 2005. Optimum Sensor Localization/Selection in a Diagnostic/Prognostic Architecture. PhD Thesis, Georgia Institute of Technology, USA.

News:

- 2014 Impact Factor for *JZUS-C*: 0.415
- Journal APP available now



iTunes Preview

Overview Music Video Charts

Front Inform Tech Electron Eng [View More by This Developer](#)

By Springer

Open iTunes to buy and download apps.



[View in iTunes](#)

This app is designed for both iPhone and iPad

Free

This app is designed for both iPhone and iPad

Free

Category: Reference
Released: Jun 26, 2015
Version: 3.02
Size: 8.4 MB
Language: English
Seller: Springer Science and Business Media, LLC
© Springer Science+Business Media
Rated 4+

Compatibility: Requires iOS 6.0 or later. Compatible with iPhone, iPad, and iPod touch. This app is optimized for iPhone 5.

Customer Ratings

We have not received enough ratings to display an average for the current version of this application.

More by Springer

Description

Tap into the most recent developments in Electrical and Electronic Engineering with the Frontiers of Information Technology & Electronic Engineering app. Frontiers of Information Technology & Electronic Engineering (FITEE) is a peer-reviewed journal published by Springer Science+Business Media. The Journal publishes the latest developments and achievements in Computer Science and Electric and Electronic Engineering. Contents include scientific research articles, reviews, science letters, new technical notes and methods, and more.

This free app provides valuable features including:

- Save and share articles
- Advanced search
- Document details - including abstracts

Coverage includes computer science and engineering, electrics, electronics, information sciences, automation, control, communication as well as applied mathematics related to the computer area.

Front Inform Tech Electron Eng Support

Journal Content

All Volumes & Issues
Volume 1 / 2010 - Volume 5 / 2015

- Volume 16 - 6 Issues (01/15 - 06/15)
 - Issue 6 - June 2015
 - Issue 5 - May 2015
 - Issue 4 - April 2015
 - Issue 3 - March 2015
 - Issue 2 - February 2015
 - Issue 1 - January 2015
- Volume 15 - 12 Issues (01/14 - 12/14)
- Volume 14 - 12 Issues (01/13 - 12/13)
- Volume 13 - 12 Issues (01/12 - 12/12)

About Us

Frontiers of Information Technology & Electronic Engineering

Frontiers of Information Technology & Electronic Engineering presents the latest developments and achievements in Computer Science and Electric & Electronic Engineering. The journal provides a forum for high-quality research communications, and addresses all aspects of original theoretical and experimental results and their applications in forms of Reviews, Original Research Articles and Science Letters.

Frontiers of Information Technology & Electronic Engineering covers research in computer science & engineering, electrics, electronics, information sciences, automation, control, communication as well as applied mathematics related to the computer area. Contents include scientific research articles, reviews, science letters, new technical notes and methods, and more

Published in partnership with
Zhejiang University Press