

Electronic Supplementary Material

A. Simulation models

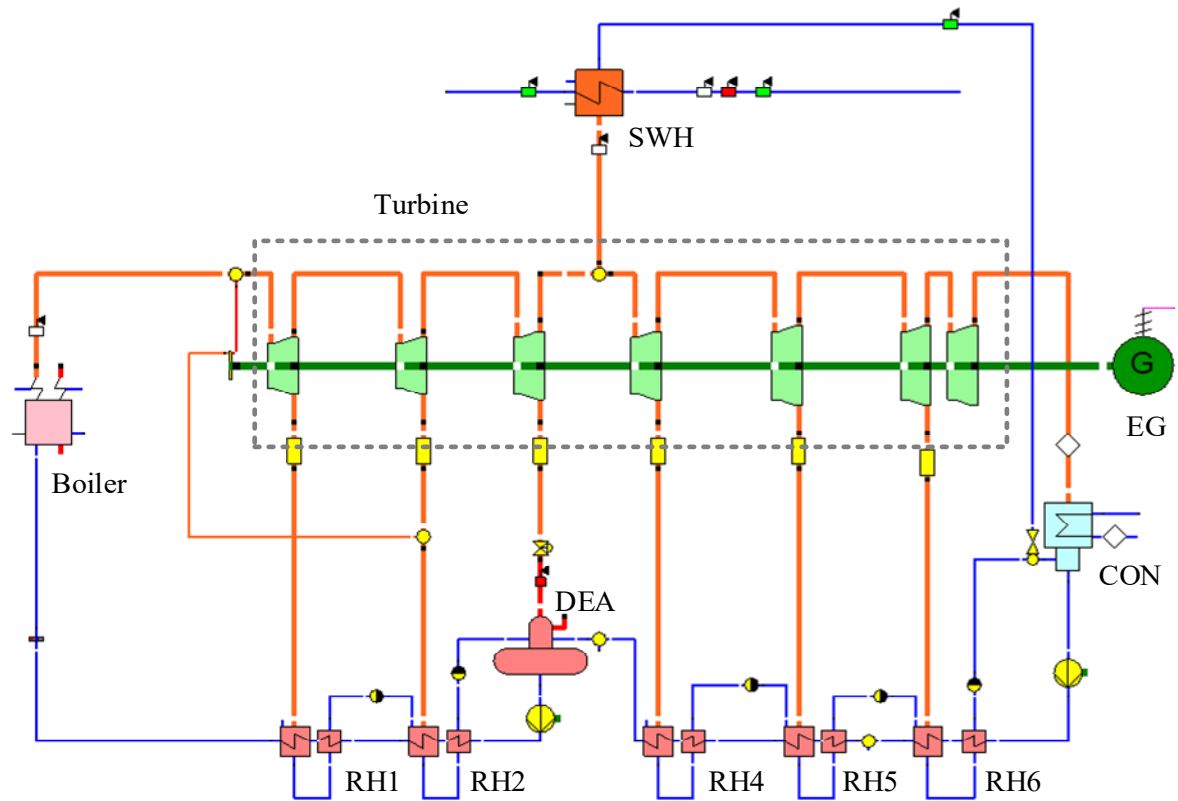

(a)

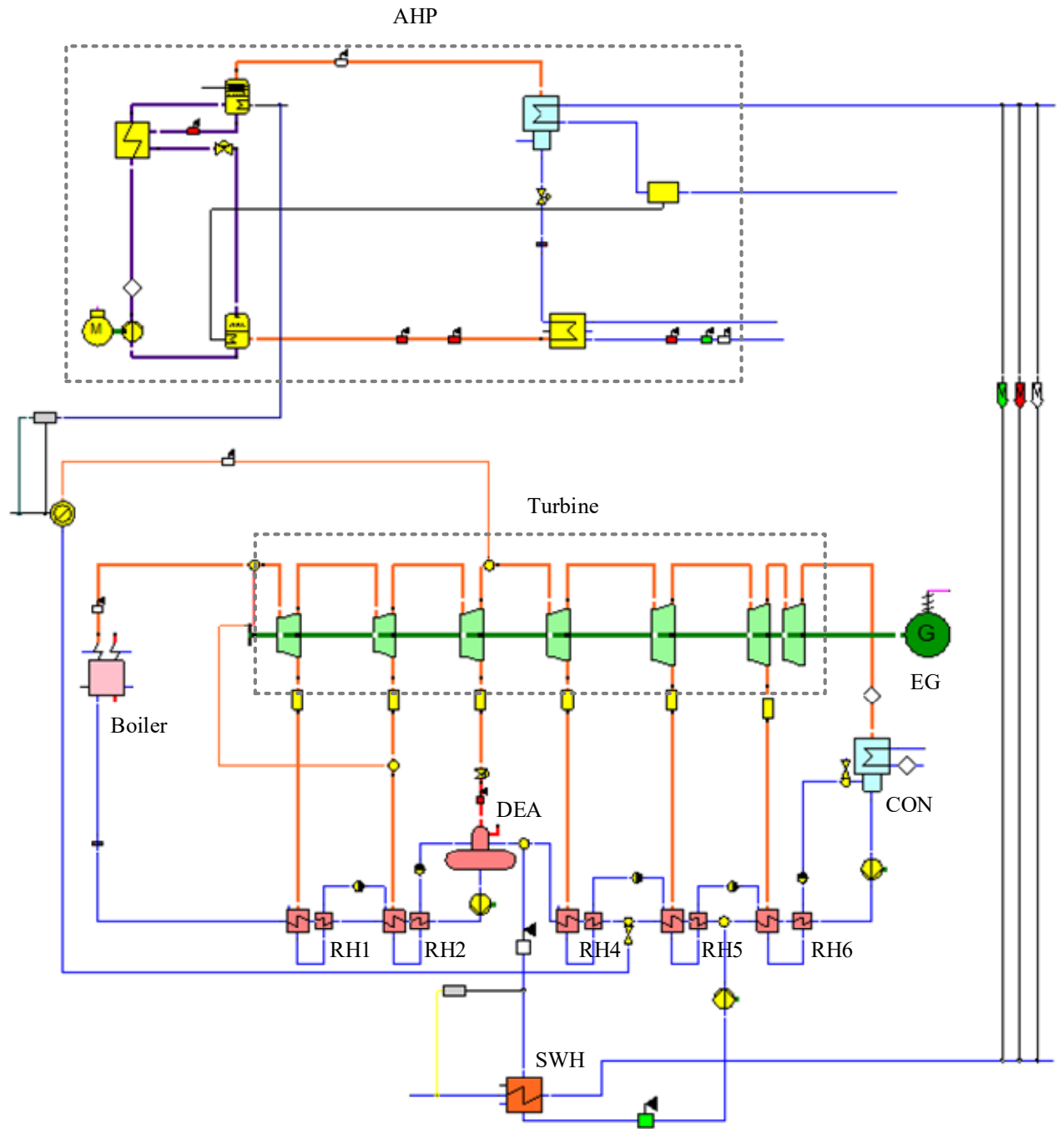

(b)

Fig. A1 Simulation models of the studied systems

(a) Reference biomass-fired cogeneration unit; (b) proposed biomass-fired cogeneration system

B. Thermodynamic properties of main nodes in studied systems

The thermodynamic properties of the main nodes displayed in Figs. 1 and 2 are detailed in Tables B1 and B2.

Table B1 Properties of the main nodes in the conventional biomass-fired cogeneration unit

Node	Stream	Temperature/°C	Pressure/MPa	Flow rate/(kg·s ⁻¹)
1	steam	535.0	9.40	38.89
2	steam	388.4	2.70	2.44
3	steam	349.7	1.29	1.81
4	steam	288.0	1.08	1.22
5	steam	179.5	0.35	1.50
6	steam	117.9	0.17	1.68
7	steam	84.0	0.06	2.55
8	steam	32.5	4.90 (kPa)	22.14
9	steam	288.8	1.14	5.56
10	water	32.6	0.59	33.42
11	water	81.0	0.58	32.42
12	water	110.3	0.57	32.42
13	water	134.9	0.56	32.42
14	water	158.1	12.12	38.89
15	water	186.3	12.11	38.89
16	water	220.0	12.10	38.89
17	water	191.9	2.70	2.44
18	water	163.7	1.29	4.25
19	water	115.9	0.35	1.50
20	water	86.6	0.17	3.18
21	water	38.2	0.06	5.73
22	water	76.0	1.14	5.56
23	water	50.0	0.20	73.14
24	water	99.0	0.20	73.14

Table B2 Properties of the main nodes in the proposed biomass-fired cogeneration system

Node	Stream	Temperature/°C	Pressure/MPa	Flow rate/(kg·s ⁻¹)
1	steam	535.0	9.40	38.89
2	steam	388.4	2.70	2.44
3	steam	349.7	1.29	1.81
4	steam	302.7	1.25	1.05
5	steam	181.2	0.38	3.20
6	steam	115.9	0.17	3.37
7	steam	85.3	0.06	2.21
8	steam	32.5	4.90 (kPa)	23.22
9	steam	303.5	1.31	1.58
10	water	32.6	0.59	32.01
11	water	82.3	0.58	32.01
12	water	111.2	0.57	65.31
13	water	137.7	0.56	66.90
14	water	158.1	12.12	38.89
15	water	186.3	12.11	38.89
16	water	220.0	12.10	38.89
17	water	191.9	2.70	2.44
18	water	163.7	1.29	4.25
19	water	117.0	0.38	3.20
20	water	86.7	0.17	6.57
21	water	38.2	0.06	8.78
22	water	120.0	1.31	1.58
23	water	50.0	0.20	73.14
24	water	62.3	0.20	73.14
25	water	72.6	0.15	73.14
26	water	99.0	0.15	73.14
27	water	22.6	0.20	138.89
28	water	27.5	0.20	138.89
29	water	137.7	0.56	33.3
30	water	80.0	0.56	33.3