

FAK and Pyk2 in disease

James M. Murphy, Hyeonsoo Park, Ssang-Taek Steve Lim (✉)

Department of Biochemistry and Molecular Biology, College of Medicine, University of South Alabama, Mobile, Alabama 36688, USA

© Higher Education Press and Springer-Verlag Berlin Heidelberg 2016

Abstract Focal adhesion kinase (FAK) and proline-rich tyrosine kinase 2 (Pyk2) are non-receptor protein tyrosine kinases that are involved in cell proliferation, migration and survival. Current research of FAK and Pyk2 is greatly focused in cancer biology and several small molecule inhibitors are being tested under clinical development. Like cancer, certain chronic diseases such as cardiovascular disease, bone disease, fibrosis, rheumatoid arthritis, and neurological disorders, share malignant characteristics of cancer. Accumulating evidence has demonstrated that FAK and Pyk2 contribute to other proliferative and degenerative diseases. Thus, the goal of this review is to briefly highlight studies that have implicated FAK and Pyk2 as players in disease progression.

Keywords FAK, Pyk2, FRNK, disease

Introduction

Focal adhesion kinase (FAK) and proline-rich tyrosine kinase 2 (Pyk2) are non-receptor protein tyrosine kinases that comprise the FAK family of kinases. FAK and Pyk2 are activated by various transmembrane receptors, such as integrins, growth factor, G-protein coupled and cytokine receptors (Mitra et al., 2005; Lim et al., 2010a), while Pyk2 is also activated by changes in intracellular Ca^{2+} concentrations (Lev et al., 1995; Schlaepfer et al., 1999). FAK and Pyk2 regulate fundamental cellular processes including cell adhesion, migration, proliferation and survival in various cell types (Avraham et al., 2000; Peng and Guan 2011). FAK is ubiquitously expressed in most cell types, while Pyk2 is primarily expressed in cells of the central nervous system and hematopoietic lineages (Avraham et al., 1995; Avraham et al., 2000; Schlaepfer et al., 1999), suggesting that they might have different importance based on the disease. Since FAK and Pyk2 are upregulated in various cancers (Wendt et al., 2013; Zhao and Guan, 2009), most studies and reviews focus on how they function in cancer (Lipinski and Loftus 2010; Sulzmaier et al., 2014). However, FAK and Pyk2 have been shown to be key molecules in other ailments such as cardiovascular disease, bone disease, fibrosis, rheumatoid

arthritis, and neurological disorders (Fig. 1), and various genetic models have been used to further understand their roles in these diseases (Table 1). Here, we provide an updated perspective on FAK and Pyk2 in disease.

FAK family kinase structure

FERM domain

FAK and Pyk2 share approximately 48% amino acid identity (Avraham et al., 2000). They are comprised of three domains: N-terminal FERM (band 4.1, ezrin, radixin, moesin), central kinase, and C-terminal domains (Fig. 2). The FERM domain was found to contain three distinct lobes (F1, F2, F3) (Ceccarelli et al., 2006). Both the FAK and Pyk2 FERM domains contain a conserved nuclear localization sequence (NLS) (Ossovskaya et al., 2008) allowing them to localize to the nucleus, where they have been found to regulate various proteins, in a kinase-independent fashion, via interactions with the FERM domain. FAK family kinases have been shown to promote cell survival through their FERM-mediated regulation of p53 (Lim et al., 2008; Lim et al., 2010b). Lim et al. showed that the FERM domain acts as a scaffold for Mdm-2 and p53 via their interactions with the F3 and F1 lobes, respectively, thus enhancing p53 ubiquitination (Lim et al., 2008; Lim et al., 2010b). Recently FAK has been shown to regulate vascular cell adhesion molecule-1 (VCAM-1) expression through FERM-mediated degradation of GATA4 transcription factor (Lim et al., 2012). These findings

Received December 14, 2015; accepted December 30, 2015

Correspondence: Ssang-Taek Steve Lim

E-mail: stlim@southalabama.edu

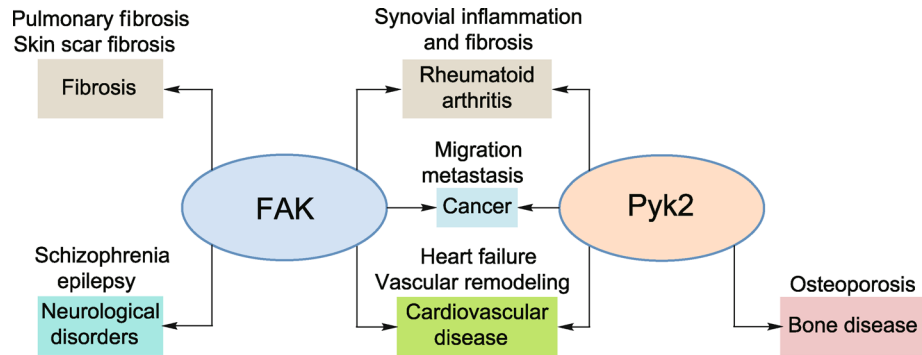

Figure 1 Overview of FAK and Pyk2 in disease. Diagram of diseases in which FAK and/or Pyk2 have been implicated in are illustrated.

demonstrate previously unknown kinase-independent nuclear functions of FAK and Pyk2.

Kinase domain

FAK and Pyk2 have 60% homology of the central kinase domain (Avraham et al., 2000), which can be seen in their conserved phosphorylatable tyrosine residues (Avraham et al., 2000). Activation of integrins, growth factor and cytokine receptors induce rapid autophosphorylation of Y397 of FAK and Y402 of Pyk2 (Sasaki et al., 1995; Avraham et al., 2000). These phosphorylated tyrosine residues provide a binding site for Src, which then further activates FAK and Pyk2 through phosphorylation of a conserved activation loop (FAK-Y576/Y577 and Pyk2-Y579/Y580) (Avraham et al., 2000; Mitra et al., 2005) (Fig. 2). Crystal structure of FAK FERM-kinase has revealed an auto-inhibited conformation by which FAK FERM domain blocks the kinase domain (Lietha et al., 2007); however, it is currently not known if Pyk2 exhibits the same auto-inhibited conformation. It has been reported that activation of integrin-mediated signaling may cause a conformational shift in FAK leading to FAK FERM dissociation from the kinase domain, promoting FAK activation (Barsukov et al., 2003; Cooper et al., 2003).

Recent studies showed that phosphatidylinositol 4, 5-bisphosphate (PIP2) binding to FAK FERM F2 domain could activate the kinase by releasing FERM-kinase interaction (Cai et al., 2008; Goñi et al., 2014; Zhou et al., 2015).

C-terminal domain

The C-terminal domain of FAK and Pyk2 are comprised of two proline-rich regions and FAT (focal adhesion targeting) domain (Fig. 2) (Parsons, 2003). Paxillin and talin are able to bind to the FAK FAT domain, resulting in FAK localization at focal adhesions. On the other hand, the Pyk2 FAT domain does not interact with talin, which results in a more diffused cytoplasmic localization. An endogenous inhibitor of FAK, known as FRNK (FAK-related non-kinase), is transcribed via an intronic promoter region found in the FAK gene (Richardson and Parsons, 1996). FRNK is a truncated version of FAK, lacking the N-terminal and central kinase domains (Richardson and Parsons, 1996). FRNK expression is restricted to smooth muscle cell-rich tissues, where it plays an important role in smooth muscle cell differentiation (Taylor et al., 2001). A similar inhibitor for Pyk2 (PRNK) was reported at the mRNA level (Xiong et al., 1998).

Table 1 Genetic models for the study of FAK and Pyk2 functions in disease.

Target cells (genotype)	Promoter	Drives	Result	References
Cardiomyocyte (FAK knockout)	β MHC	SuperFAK	Protected against ischemia/reperfusion	Cheng et al., 2012
Ventricular cardiomyocyte (FAK knockout)	MLC2v	Cre	Increased pressure-induced hypertrophy	Peng et al., 2006
Smooth muscle cells	SM-MHC	CreER ^{T2}	Attenuated pressure-induced hypertrophy	DiMichele et al., 2006
Global (FRNK knockout)			Prevented N-cadherin expression, and intimal hyperplasia	Mui et al., 2015
Global (Pyk2 knockout)			SMCs were unable to re-differentiate after artery ligation	Sayers et al., 2008
Global (Pyk2 knockout)			Pyk2 null mice show increased bone mass from increased bone formation and decreased bone resorption	Buckbinder et al., 2007 and Gil-Hen et al., 2007
Global (inducible FAK knockout)	Ros 26 locus	CreER ^{T2}	Reduced murine arthritic synovial fibroblast invasion <i>in vitro</i> , but not <i>in vivo</i>	Shelef et al., 2014
Dorsal forebrain (FAK knockout)	emx1	Cre	Abnormal cortical laminar organization and cortical dysplasia	Beggs et al., 2003

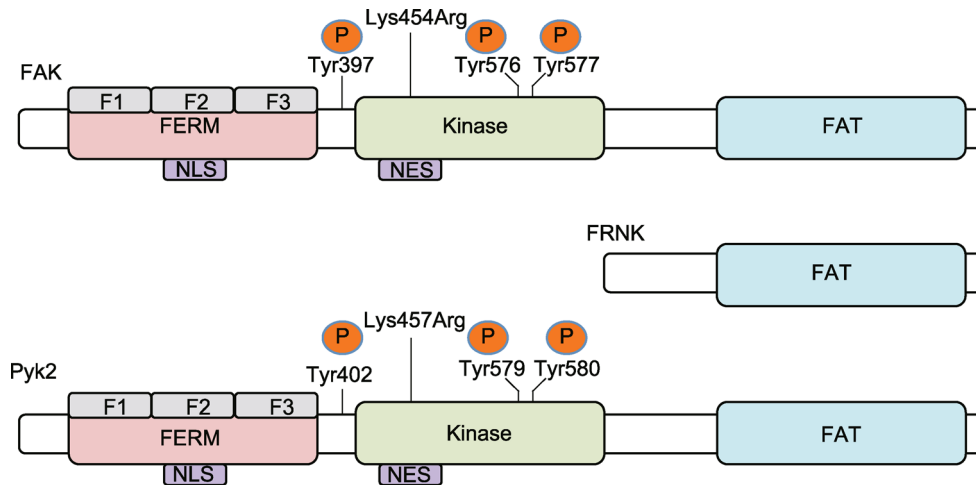

Figure 2 Molecular structure of FAK, FRNK and Pyk2. The main domains of FAK, FRNK and Pyk2 are shown. FAK and Pyk2 are comprised of three domains: FERM (4.1, ezrin, radixin, moesin), central kinase and FAT (focal adhesion targeting) domains. The FERM domain is further divided into three subdomains: F1, F2 and F3. FAK and Pyk2 contain both a nuclear localization sequence (NLS) and a nuclear export sequence (NES), which are located in the FERM and kinase domains, respectively. FAK and Pyk2 share several conserved phosphorylatable tyrosine (Tyr) residues: the autophosphorylation site (Tyr397 and Tyr402) and the activation loop (Tyr576/577 and Tyr579/580). A lysine (Lys) mutation in the kinase domain of FAK (Lys454) and Pyk2 (Lys457) results in loss of kinase activity. FRNK (FAK-Related Non-Kinase), which comprises only the C-terminal domain of FAK, is an endogenous inhibitor of FAK.

Cancer

FAK and Pyk2 have been extensively studied in cancer due to their increased expression and activation compared to normal tissue; as such, there are several reviews that look at expression, mouse models and inhibitors of FAK family kinases in cancer (Lipinski and Loftus, 2010; Sulzmaier et al., 2014; Yoon et al., 2015). Since this review is focused on illustrating the roles of FAK and Pyk2 in various diseases, we will briefly highlight some recent findings that FAK plays a pro-tumorigenic role in cancer cells and in the tumor microenvironment.

Normally cell growth is tightly regulated via extra- and intra-cellular signaling events that lead to cell cycle progression. However, cancer cells have escaped this regulation, and exhibit unrestricted growth. Therefore, DNA-damaging therapies, such as doxorubicin and radiation, have been used to inhibit DNA replication, ultimately leading to apoptosis. A problem facing these therapies is that some tumors become resistant to treatment, but a recent study has revealed a novel role for FAK in endothelial cells (ECs) in promoting a chemoresistant environment (Tavora et al., 2014). In EC specific inducible FAK knock out mice (EFKO), where the *Pdgfrb* promoter drives Cre expression, tumor cells were more sensitive to DNA-damaging therapy compared to wild-type mice (Tavora et al., 2014). They found that FAK was required for DNA-damage-induced activation of NF- κ B and cytokine production in ECs, and that these cytokines were sensitizing the tumor cells to chemotherapy (Tavora et al., 2014). However, it is not known that this resistance was mediated in a kinase-dependent or-independent manner.

The immune system is able to detect and clear out aberrant cells, however, some cancer cells are able to survive by suppressing the immune system. As such, immunotherapies that trigger the immune system to fight cancer cells have gained a lot of traction in recent years. A more recent study reported that nuclear FAK in cancer cells was able to create a pro-tumorigenic environment by suppressing the immune system (Serrels et al., 2015). They found that injection of FAK null squamous cell carcinoma (SCC) cells into immunocompetent mice resulted in tumor regression after 3 weeks, and that this regression was due to killer T cells (CD8+ T cells), which are responsible for clearing out tumor cells (Serrels et al., 2015). Interestingly, they found that nuclear FAK in SCC cells promoted CCL5 transcription, a chemokine responsible for regulatory T cell (Treg) recruitment, and that these Tregs were able to provide a pro-tumorigenic environment through suppression of CD8+ T cells (Serrels et al., 2015). Taken together, these two studies suggest that targeting FAK in cancer could prove beneficial when used in combination with other cancer therapies.

Cardiovascular disease

Cardiovascular disease (CVD) is any disease that affects the heart, such as heart failure, or the vascular system, such as atherosclerosis and vascular remodeling. Cardiovascular disease is the leading cause of death in developed countries; therefore there have been numerous studies done to elucidate underlying mechanisms of CVD in order to find potential therapeutic targets. Some of these studies have illustrated important roles of FAK family kinases in CVD.

Heart failure

Heart failure arises when the heart is unable to adequately supply the body with blood and oxygen, depriving tissue of valuable nutrients. Some of the underlying causes of heart failure, which can include narrowing of the coronary arteries and high blood pressure, require the heart to work harder in order to supply tissues with enough blood. Since the heart is a muscle, this increased work results in hypertrophy of cardiac muscle cells (cardiomyocytes), and if the underlying causes are not addressed, this hypertrophy will eventually result in heart failure. Studies done by several groups have revealed that the FAK family kinases play an important role in the progression of heart failure.

Early studies found that there was an increased association between FAK and $\beta 3$ integrin in pressure-overloaded hypertrophic hearts (Kuppuswamy et al., 1997) and that FAK was required for integrin-mediated phenylephrine-induced hypertrophy of rat cardiomyocytes *in vitro* (Taylor et al., 2000), suggesting that FAK might play an important role in the development of hypertrophy. FAK and Pyk2 expression and activation in the heart was found to be increased in a pressure-overload model of heart failure, which develops left ventricular hypertrophy (LVH) in the first 8 weeks and progresses to heart failure 16–24 weeks post surgery (Bayer et al., 2002). Interestingly, Pyk2 expression appeared to precede the development of LVH, while FAK expression was highest during the transition from LVH to heart failure (Bayer et al., 2002).

There has been some conflict on whether or not FAK is required for cardiac hypertrophy. Two groups made use of cardiomyocyte specific FAK knockout mice (they were termed CFKO (Peng et al., 2006) or MFKO (DiMichele et al., 2006)) to study the importance of FAK in cardiac hypertrophy in a pressure overload model. These studies utilized a mouse in which Cre was introduced into the myosin light chain 2v (MLC2v) gene locus, resulting in cardiomyocyte restricted Cre expression (Chen et al., 1998). While both groups reported that FAK knockout did not affect basal cardiac functions, one found that CFKO had increased hypertrophy (Peng et al., 2006) and the other found that MFKO showed increase in left ventricular wall thickness, myocyte cross-sectional area, and hypertrophy-associated arterial natriuretic factor upon pressure overload (DiMichele et al., 2006). Peng et al. knocked out FAK by crossing mice containing loxP sites flanking exon 3 (Shen et al., 2005) with the MLC2v-Cre mice (Chen et al., 1998), and that significant knockout was observed from 2 weeks till 40 weeks after birth (Peng et al., 2006). Transverse aortic constriction (TAC) or angiotensin II treatment resulted in eccentric hypertrophy in CFKO, at 10 and 14 days respectively, when compared to wild-type mice, and 9-month-old mice showed signs of ventricular dilation and heart failure (Peng et al., 2006). Interestingly, they found that mitochondrial organization and

structure was altered in FAK null cardiomyocytes compared with control (Peng et al., 2006). On the other hand, DiMichele et al. achieved FAK knockout by crossing mice with loxP sites flanking an exon in the kinase domain with MLC2v-Cre mice (Chen et al., 1998), and that significant FAK reduction was not observed until 3 months after birth (DiMichele et al., 2006). They found that MFKO mice had decreased hypertrophy compared to wild-type after 4 weeks of TAC, and that MFKO mice were progressing to heart failure, as determined by significant increases in wet lung weight, compared to wild-type mice after 8–12 weeks of TAC (DiMichele et al., 2006). The discrepancies seen between the two studies could be due to various factors: where loxP recombination occurred in the FAK gene, age of mice loxP recombination occurred, strain of the mice, age of mice when experiments were performed, and technical differences in TAC. However, a study by Clemente et al. seems to support that FAK is required for the progression of hypertrophy (Clemente et al., 2007). They demonstrated that siRNA mediated knockdown of FAK was able to prevent and reverse overload-induced LVH *in vivo* (Clemente et al., 2007).

During heart failure, blood may be unable to reach certain cardiomyocytes, resulting in ischemia from lack of blood and oxygen; therefore it is important to understand how these cells react to incidents of ischemia/reperfusion. Recent studies have found evidence to suggest that FAK might play a protective role in cardiomyocytes following ischemia/reperfusion (Hakim et al., 2009; Cheng et al., 2012). Hakim et al. used a cardiomyocyte specific FAK knockout (MFKO) model to evaluate the protective role of FAK during ischemia/reperfusion (Hakim et al., 2009). They found that MFKO mice had a significant increase in infarct area and increased apoptosis compared to control mice (Hakim et al., 2009). Cheng et al. revealed that transgenic mice expressing a super-activatable FAK mutant (K578/581E, termed SuperFAK), which has increased catalytic activity compared to wild-type FAK, was able to protect cardiomyocytes following ischemia/reperfusion (Cheng et al., 2012).

Vascular remodeling

Vascular remodeling is the result of smooth muscle cell (SMC) plasticity. Changes in blood flow or vessel injury result in the de-differentiation and proliferation of SMCs, which can lead to stiffening and thickening of the vessel wall, decreased lumen area and blood flow. Studies have revealed that FRNK, which is endogenously expressed in SMCs, plays an important role in regulating SMC plasticity, and its expression is increased in differentiated SMCs (Taylor et al., 2001; Sayers et al., 2008). Sayers et al. found that SMCs isolated from FRNK^{-/-} mice, where the intronic FRNK promoter has been removed without affecting FAK expression, had increased FAK activity and decreased SMC contractile gene expression when compared to wild-type

mice (Sayers et al., 2008). They also reported that FRNK^{-/-} mice were unable to promote the re-differentiation of SMCs after carotid artery ligation, a model of vascular remodeling, compared with wild-type mice (Sayers et al., 2008).

De-differentiated SMCs have increased extracellular matrix (ECM) production, which results in changes to the extracellular environment and increased stiffness. Recent studies have demonstrated that FAK plays an important role in the stiffness-induced proliferation of SMCs in vivo (Klein et al., 2009; Bae et al., 2014; Mui et al., 2015). Klein et al. found that cyclin D1 expression was regulated by increased ECM upon vascular injury and was a result of stiffness-induced activation of FAK (Klein et al., 2009). FAK activity was increased in cells plated on high stiffness hydrogels, resulting in increased Rac activation and cyclin D1 expression (Klein et al., 2009). Bae et al. followed up this study by showing that increased ECM stiffness resulted in an increase in intracellular stiffness (Bae et al., 2014). This intracellular stiffness, which was a result of increased Rac activity, resulted in the continued activation of FAK and cyclin D1 expression (Bae et al., 2014). These findings hint at a feedback loop in which FAK activity remains elevated, promoting SMC proliferation and increased vascular remodeling. More recently, Mui et al. used a SMC specific inducible FAK knockout model (SFKO) to study the role of FAK in vascular remodeling (Mui et al., 2015). In this genetic model, the SM-MHC promoter drives Cre-ERT2 and tamoxifen treatment results in deletion of FAK. Using the emoral wire injury model of SMC proliferation, they found that SFKO mice had significantly less neointimal hyperplasia compared to wild-type mice (Mui et al., 2015). Taken together, these findings suggest that FAK is a potential therapeutic target for the treatment of vascular remodeling.

Bone disease

Normally, bones are constantly being altered through a delicate balance between bone-forming osteoblasts and bone-absorbing osteoclasts (Ray et al., 2012). When this balance is disrupted, it can lead to osteoporosis, the most common form of bone disease. Osteoporosis is characterized by a decrease in bone mass as a result of increased osteoclast activity and/or decreased osteoblast activity. Since osteoporosis typically affects people over the age 50, especially postmenopausal women, it is important to understand the mechanisms that regulate osteoclasts and osteoblasts differentiation and function in order to devise better treatment options. Due to Pyk2 being predominantly expressed in cells of hematopoietic lineage, people began to study what function Pyk2 had in osteoclasts and osteoblasts.

Upon attachment to bone, osteoclasts begin to spread and fuse together forming multinucleated cells (Suda et al., 1997). These fused osteoclasts then form a sealing zone, creating an

isolated acidic environment in which bone is degraded and absorbed (Suda et al., 1997). Duong et al. were one of the first groups to report that Pyk2 might play an important role osteoclast function (Duong et al., 2001). Using adenovirus expressing antisense Pyk2, they found that not only was Pyk2 required for the proper attachment and spreading of osteoclasts, Pyk2 knockdown also resulted in impaired sealing zone formation and bone absorption (Duong et al., 2001). There has been some conflict on whether or not Pyk2 was performing a similar role in vivo in regulating bone formation and degradation. Two groups published studies that Pyk2^{-/-} mice, while viable and fertile, had increased bone mass compared to wild-type mice (Buckbinder et al., 2007; Gil-Henn et al., 2007). Buckbinder et al. reported that this increase in bone mass was due to increased bone formation and not from impaired osteoclast function. This increased bone formation was due to increased osteoblast differentiation, suggesting that Pyk2 is a cell-autonomous inhibitor of osteoprogenitor stem cells (Buckbinder et al., 2007). Using OVX (ovariectomized) rats, a preclinical model of postmenopausal osteoporosis, pharmacological Pyk2 inhibition was able to preserve bone density by promoting bone formation without altering bone resorption (Buckbinder et al., 2007). On the other hand, Gil-Henn et al. found that the increased bone mass seen in Pyk2^{-/-} mice was due to impaired osteoclast function (Gil-Henn et al., 2007). They found that osteoclasts isolated from Pyk2^{-/-} mice were unable to form sufficient sealing zones and had decreased bone resorption when compared with wild-type osteoclasts (Gil-Henn et al., 2007). The differences seen between these two groups might be attributed to age of the mice, 16–18 weeks of age (Buckbinder et al., 2007) and 2–10 weeks of age (Gil-Henn et al., 2007), suggesting that Pyk2 function in osteoclasts changes with age. Thus these studies implicate the importance of Pyk2 in the homeostasis of adult bones, and as a potential target in the treatment of osteoporosis.

Fibrosis

Fibrosis occurs when there is an excess deposition of ECM during the wound healing process of tissues and it can lead to severe organ failure and death. Fibrosis frequently occurs in the lung, skin and heart (Wynn, 2011). Transforming growth factor- β (TGF- β) plays a pivotal role in ECM production and modulation of immune function (McCartney-Francis et al., 1998), suggesting that inhibition of TGF- β signaling pathways might provide therapeutic options for fibrosis. However, TGF- β is involved in various cellular processes, and targeting TGF- β directly may result in negative side effects (McCartney-Francis et al., 1998; Leask and Abraham 2004). FAK was found to be required for TGF- β -induced activation of JNK and pro-fibrotic gene expression (Liu et al., 2007). Overexpression of FRNK, an endogenous inhibitor of FAK, was

reported to inhibit TGF- β 1-induced activation of ERK and p38MAPK, thus preventing myofibroblast differentiation both *in vitro* and *in vivo* (Ding et al., 2008). More recently a group reported that pharmacological inhibition of FAK was able to prevent pulmonary fibrosis through decreased profibrotic gene expression in mice (Lagares et al., 2012). These findings have implicated FAK as an important signaling molecule in the progression of fibrosis, and could provide a potential therapeutic target for fibrosis (Lagares and Kapoor, 2013).

Rheumatoid arthritis

Rheumatoid arthritis (RA) is a chronic autoimmune joint disease that typically occurs at the small joints of the hands and feet. In RA, macrophages, derived from circulating monocytes, augment inflammation in the synovial region resulting in the destruction of cartilage and bone. Previous studies demonstrated that FAK is closely involved in monocyte differentiation into macrophages (Kharbanda et al., 1995), and macrophages isolated from RA synovial tissue are arthritis and human RA samples have showed that there is increased phosphorylation of FAK Y397 and Pyk2 Y402 in synovial cells (Matsumoto et al., 2002; Shahrara et al., 2007). Matsumoto et al. showed that intra-articular injection of FRNK adenovirus in a rat model of arthritis prevented the recruitment and differentiation of monocytes to synovial tissue (Matsumoto et al., 2002).

Synovial fibroblasts play a role in the progression of RA by invading the surrounding cartilage and bone, leading to joint destruction. A recent study found that pharmacological FAK inhibitors reduced the invasiveness and migration of synovial fibroblasts isolated from patients *in vitro* (Shelef et al., 2014). Interestingly, they found that Cre-inducible FAK knockout mice crossed with mice overexpressing TNF- α , a mouse model of arthritis, reduced synovial fibroblast invasion, but did not completely block RA progression (Shelef et al., 2014). This study suggested that a combinational treatment with a FAK inhibitor would be beneficial for RA.

Neurological disorders

FAK has found to be a key-signaling molecule in neuron cell assembly, remodeling and migration during neuronal development (Beggs et al., 2003). Beggs et al. found that neuronal specific deletion of FAK in the dorsal forebrain, where the neuronal specific *emx1* promoter drives Cre, altered cortical dendritic cell branching and orientation, resulting in neuronal mislocalization and cortical dysplasia (Beggs et al., 2003). This study indicates that FAK expression in neuronal cells is critical to maintain the normal development of neurons.

Schizophrenia is a severe brain disorder which causes paranoia and hallucinations; however not much is currently

known on what causes schizophrenia. It is believed that there might be altered neural migration during brain development in schizophrenia. A recent study looked at the role of FAK in patients with schizophrenia. They found that olfactory neurosphere-derived (ONS) cells isolated from schizophrenic patients exhibited increased FAK phosphorylation, decreased cell attachment and increased cell motility which was returned to normal upon FAK inhibition (Fan et al., 2013). This study suggests that altered FAK activity might play an important role in the development of schizophrenia.

Epilepsy, which is characterized by recurrent seizures, is the most common neurological disorder. Studies seem to suggest that mossy fiber sprouting (MFS) can cause increased seizure susceptibility. A recent study by Song et al. found a potential pathway in which FAK plays a key role in hippocampal MSF formation (Song et al., 2015). They found that FAK activation was increased during development of MFS, and increased Ras expression and MFS formation (Song et al., 2015). This suggests that inhibition of FAK activity may prevent MFS formation, thus resulting in less recurrent seizures.

Conclusion

Here we have highlighted some studies that show involvement of the FAK family kinases in a range of diseases, including, but not limited to: cancer, cardiovascular disease, bone disease, fibrosis, rheumatoid arthritis, and neurological disorders. Currently there are preclinical and clinical trials for small molecule FAK/Pyk2 inhibitors being tested as treatment options for cancer; however, it is possible that these inhibitors might work in other diseases, and the effectiveness should be investigated further.

Acknowledgements

This work was supported by American Heart Association 12SDG10970000 (to S. L.) and 2013–2015 Abraham Mitchell Cancer Research Fund (to S. L.).

Compliance with ethics guidelines

James Murphy, Hyeonsoo Park, and Steve Lim declare that they have no conflict of interest.

This article does not contain any studies with human or animal subjects performed by any of the authors.

References

- Avraham H, Park S Y, Schinkmann K, Avraham S (2000). RAFTK/Pyk2-mediated cellular signalling. *Cell Signal*, 12(3): 123–133
- Avraham S, London R, Fu Y, Ota S, Hiregowdara D, Li J, Jiang S, Pasztor L M, White R A, Groopman J E, et al (1995). Identification

- and characterization of a novel related adhesion focal tyrosine kinase (RAFTK) from megakaryocytes and brain. *J Biol Chem*, 270(46): 27742–27751
- Bae Y H, Mui K L, Hsu B Y, Liu S L, Cretu A, Razinia Z, Xu T, Puré E, Assoian R K (2014). A FAK-Cas-Rac-lamellipodin signaling module transduces extracellular matrix stiffness into mechanosensitive cell cycling. *Sci Signal*, 7(330): ra57
- Barsukov I L, Prescott A, Bate N, Patel B, Floyd D N, Bhanji N, Bagshaw C R, Letinic K, Di Paolo G, De Camilli P, Roberts G C, Critchley D R (2003). Phosphatidylinositol phosphate kinase type 1 γ and beta1-integrin cytoplasmic domain bind to the same region in the talin FERM domain. *J Biol Chem*, 278(33): 31202–31209
- Bayer A L, Heidkamp M C, Patel N, Porter M J, Engman S J, Samarel A M (2002). PYK2 expression and phosphorylation increases in pressure overload-induced left ventricular hypertrophy. *Am J Physiol Heart Circ Physiol*, 283(2): H695–H706
- Beggs H E, Schahin-Reed D, Zang K, Goebbels S, Nave K A, Gorski J, Jones K R, Sretavan D, Reichardt L F (2003). FAK deficiency in cells contributing to the basal lamina results in cortical abnormalities resembling congenital muscular dystrophies. *Neuron*, 40(3): 501–514
- Buckbinder L, Crawford D T, Qi H, Ke H Z, Olson L M, Long K R, Bonnette P C, Baumann A P, Hambor J E, Grasser W A 3rd, Pan L C, Owen T A, Luzzio M J, Hulford C A, Gebhard D F, Paralkar V M, Simmons H A, Kath J C, Roberts W G, Smock S L, Guzman-Perez A, Brown T A, Li M (2007). Proline-rich tyrosine kinase 2 regulates osteoprogenitor cells and bone formation, and offers an anabolic treatment approach for osteoporosis. *Proc Natl Acad Sci USA*, 104(25): 10619–10624
- Cai X, Lietha D, Ceccarelli D F, Karginov A V, Rajfur Z, Jacobson K, Hahn K M, Eck M J, Schaller M D (2008). Spatial and temporal regulation of focal adhesion kinase activity in living cells. *Mol Cell Biol*, 28(1): 201–214
- Ceccarelli D F, Song H K, Poy F, Schaller M D, Eck M J (2006). Crystal structure of the FERM domain of focal adhesion kinase. *J Biol Chem*, 281(1): 252–259
- Chen J, Kubalak S W, Chien K R (1998). Ventricular muscle-restricted targeting of the RXR α gene reveals a non-cell-autonomous requirement in cardiac chamber morphogenesis. *Development*, 125(10): 1943–1949
- Cheng Z, DiMichele L A, Hakim Z S, Rojas M, Mack C P, Taylor J M (2012). Targeted focal adhesion kinase activation in cardiomyocytes protects the heart from ischemia/reperfusion injury. *Arterioscler Thromb Vasc Biol*, 32(4): 924–933
- Clemente C F, Tomatore T F, Theizen T H, Deckmann A C, Pereira T C, Lopes-Cendes I, Souza J R, Franchini K G (2007). Targeting focal adhesion kinase with small interfering RNA prevents and reverses load-induced cardiac hypertrophy in mice. *Circ Res*, 101(12): 1339–1348
- Cooper L A, Shen T L, Guan J L (2003). Regulation of focal adhesion kinase by its amino-terminal domain through an autoinhibitory interaction. *Mol Cell Biol*, 23(22): 8030–8041
- DiMichele L A, Doherty J T, Rojas M, Beggs H E, Reichardt L F, Mack C P, Taylor J M (2006). Myocyte-restricted focal adhesion kinase deletion attenuates pressure overload-induced hypertrophy. *Circ Res*, 99(6): 636–645
- Ding Q, Gladson C L, Wu H, Hayasaka H, Olman M A (2008). Focal adhesion kinase (FAK)-related non-kinase inhibits myofibroblast differentiation through differential MAPK activation in a FAK-dependent manner. *J Biol Chem*, 283(40): 26839–26849
- Duong L T, Nakamura I, Lakkakorpi P T, Lipfert L, Bett A J, Rodan G A (2001). Inhibition of osteoclast function by adenovirus expressing antisense protein-tyrosine kinase 2. *J Biol Chem*, 276(10): 7484–7492
- Fan Y, Abrahamsen G, Mills R, Calderón C C, Tee J Y, Leyton L, Murrell W, Cooper-White J, McGrath J J, Mackay-Sim A (2013). Focal adhesion dynamics are altered in schizophrenia. *Biol Psychiatry*, 74(6): 418–426
- Gil-Henn H, Destaing O, Sims N A, Aoki K, Alles N, Neff L, Sanjay A, Bruzzaniti A, De Camilli P, Baron R, Schlessinger J (2007). Defective microtubule-dependent podosome organization in osteoclasts leads to increased bone density in *Pyk2(-/-)* mice. *J Cell Biol*, 178(6): 1053–1064
- Goñi G M, Epifano C, Boskovic J, Camacho-Artacho M, Zhou J, Bronowska A, Martín M T, Eck M J, Kremer L, Gräter F, Gervasio F L, Perez-Moreno M, Lietha D (2014). Phosphatidylinositol 4,5-bisphosphate triggers activation of focal adhesion kinase by inducing clustering and conformational changes. *Proc Natl Acad Sci USA*, 111(31): E3177–E3186
- Hakim Z S, DiMichele L A, Rojas M, Meredith D, Mack C P, Taylor J M (2009). FAK regulates cardiomyocyte survival following ischemia/reperfusion. *J Mol Cell Cardiol*, 46(2): 241–248
- Itonaga I, Fujikawa Y, Sabokbar A, Murray D W, Athanasou N A (2000). Rheumatoid arthritis synovial macrophage-osteoclast differentiation is osteoprotegerin ligand-dependent. *J Pathol*, 192(1): 97–104
- Kharbanda S, Saleem A, Yuan Z, Emoto Y, Prasad K V, Kufe D (1995). Stimulation of human monocytes with macrophage colony-stimulating factor induces a Grb2-mediated association of the focal adhesion kinase pp125FAK and dynamin. *Proc Natl Acad Sci USA*, 92(13): 6132–6136
- Klein E A, Yin L, Kothapalli D, Castagnino P, Byfield F J, Xu T, Levental I, Hawthorne E, Janmey P A, Assoian R K (2009). Cell-cycle control by physiological matrix elasticity and in vivo tissue stiffening. *Curr Biol*, 19(18): 1511–1518
- Kuppuswamy D, Kerr C, Narishige T, Kasi V S, Menick D R, Cooper G 4th (1997). Association of tyrosine-phosphorylated c-Src with the cytoskeleton of hypertrophying myocardium. *J Biol Chem*, 272(7): 4500–4508
- Lagares D, Busnadiego O, García-Fernández R A, Kapoor M, Liu S, Carter D E, Abraham D, Shi-Wen X, Carreira P, Fontaine B A, Shea B S, Tager A M, Leask A, Lamas S, Rodríguez-Pascual F (2012). Inhibition of focal adhesion kinase prevents experimental lung fibrosis and myofibroblast formation. *Arthritis Rheum*, 64(5): 1653–1664
- Lagares D, Kapoor M (2013). Targeting focal adhesion kinase in fibrotic diseases. *BioDrugs*, 27(1): 15–23
- Leask A, Abraham D J (2004). TGF- β signaling and the fibrotic response. *FASEB J*, 18(7): 816–827
- Lev S, Moreno H, Martinez R, Canoll P, Peles E, Musacchio J M, Plowman G D, Rudy B, Schlessinger J (1995). Protein tyrosine kinase PYK2 involved in Ca²⁺-induced regulation of ion channel and MAP kinase functions. *Nature*, 376(6543): 737–745
- Lietha D, Cai X, Ceccarelli D F, Li Y, Schaller M D, Eck M J (2007).

- Structural basis for the autoinhibition of focal adhesion kinase. *Cell*, 129(6): 1177–1187
- Lim S T, Chen X L, Lim Y, Hanson D A, Vo T T, Howerton K, Larocque N, Fisher S J, Schlaepfer D D, Ilic D (2008). Nuclear FAK promotes cell proliferation and survival through FERM-enhanced p53 degradation. *Mol Cell*, 29(1): 9–22
- Lim S T, Chen X L, Tomar A, Miller N L, Yoo J, Schlaepfer D D (2010a). Knock-in mutation reveals an essential role for focal adhesion kinase activity in blood vessel morphogenesis and cell motility-polarity but not cell proliferation. *J Biol Chem*, 285(28): 21526–21536
- Lim S T, Miller N L, Chen X L, Tancioni I, Walsh C T, Lawson C, Uryu S, Weis S M, Cheresh D A, Schlaepfer D D (2012). Nuclear-localized focal adhesion kinase regulates inflammatory VCAM-1 expression. *J Cell Biol*, 197(7): 907–919
- Lim S T, Miller N L, Nam J O, Chen X L, Lim Y, Schlaepfer D D (2010b). Pyk2 inhibition of p53 as an adaptive and intrinsic mechanism facilitating cell proliferation and survival. *J Biol Chem*, 285(3): 1743–1753
- Lipinski C A, Loftus J C (2010). Targeting Pyk2 for therapeutic intervention. *Expert Opin Ther Targets*, 14(1): 95–108
- Liu S, Xu S W, Kennedy L, Pala D, Chen Y, Eastwood M, Carter D E, Black C M, Abraham D J, Leask A (2007). FAK is required for TGF β -induced JNK phosphorylation in fibroblasts: implications for acquisition of a matrix-remodeling phenotype. *Mol Biol Cell*, 18(6): 2169–2178
- Matsumoto Y, Tanaka K, Hirata G, Hanada M, Matsuda S, Shuto T, Iwamoto Y (2002). Possible involvement of the vascular endothelial growth factor-Flt-1-focal adhesion kinase pathway in chemotaxis and the cell proliferation of osteoclast precursor cells in arthritic joints. *J Immunol*, 168(11): 5824–5831
- McCartney-Francis N L, Frazier-Jessen M, Wahl S M (1998). TGF- β : a balancing act. *Int Rev Immunol*, 16(5-6): 553–580
- Mitra S K, Hanson D A, Schlaepfer D D (2005). Focal adhesion kinase: in command and control of cell motility. *Nat Rev Mol Cell Biol*, 6(1): 56–68
- Mui K L, Bae Y H, Gao L, Liu S L, Xu T, Radice G L, Chen C S, Assoian R K (2015). N-Cadherin Induction by ECM Stiffness and FAK Overrides the Spreading Requirement for Proliferation of Vascular Smooth Muscle Cells. *Cell Rep*, Ossovskaya, V., Lim, S. T., Ota, N., Schlaepfer, D. D. and Ilic, D. (2008). FAK nuclear export signal sequences. *FEBS Lett*, 582: 2402–2406
- Parsons J T (2003). Focal adhesion kinase: the first ten years. *J Cell Sci*, 116(Pt 8): 1409–1416
- Peng X, Guan J L (2011). Focal adhesion kinase: from in vitro studies to functional analyses in vivo. *Curr Protein Pept Sci*, 12(1): 52–67
- Peng X, Kraus M S, Wei H, Shen T L, Pariaut R, Alcaraz A, Ji G, Cheng L, Yang Q, Kotlikoff M I, Chen J, Chien K, Gu H, Guan J L (2006). Inactivation of focal adhesion kinase in cardiomyocytes promotes eccentric cardiac hypertrophy and fibrosis in mice. *J Clin Invest*, 116(1): 217–227
- Ray B J, Thomas K, Huang C S, Gutknecht M F, Botchwey E A, Bouton A H (2012). Regulation of osteoclast structure and function by FAK family kinases. *J Leukoc Biol*, 92(5): 1021–1028
- Richardson A, Parsons T (1996). A mechanism for regulation of the adhesion-associated proteintyrosine kinase pp125FAK. *Nature*, 380(6574): 538–540
- Sasaki H, Nagura K, Ishino M, Tobioka H, Kotani K, Sasaki T (1995). Cloning and characterization of cell adhesion kinase beta, a novel protein-tyrosine kinase of the focal adhesion kinase subfamily. *J Biol Chem*, 270(36): 21206–21219
- Sayers R L, Sundberg-Smith L J, Rojas M, Hayasaka H, Parsons J T, Mack C P, Taylor J M (2008). FRNK expression promotes smooth muscle cell maturation during vascular development and after vascular injury. *Arterioscler Thromb Vasc Biol*, 28(12): 2115–2122
- Schlaepfer D D, Hauck C R, Sieg D J (1999). Signaling through focal adhesion kinase. *Prog Biophys Mol Biol*, 71(3-4): 435–478
- Serrels A, Lund T, Serrels B, Byron A, McPherson R C, von Kriegsheim A, Gómez-Cuadrado L, Canel M, Muir M, Ring J E, Maniati E, Sims A H, Pachter J A, Brunton V G, Gilbert N, Anderton S M, Nibbs R J, Frame M C (2015). Nuclear FAK controls chemokine transcription, Tregs, and evasion of anti-tumor immunity. *Cell*, 163(1): 160–173
- Shahrara S, Castro-Rueda H P, Haines G K, Koch A E (2007). Differential expression of the FAK family kinases in rheumatoid arthritis and osteoarthritis synovial tissues. *Arthritis Res Ther*, 9(5): R112
- Shelef M A, Bennin D A, Yasmin N, Warner T F, Ludwig T, Beggs H E, Huttenlocher A (2014). Focal adhesion kinase is required for synovial fibroblast invasion, but not murine inflammatory arthritis. *Arthritis Res Ther*, 16(5): 464
- Shen T L, Park A Y, Alcaraz A, Peng X, Jang I, Koni P, Flavell R A, Gu H, Guan J L (2005). Conditional knockout of focal adhesion kinase in endothelial cells reveals its role in angiogenesis and vascular development in late embryogenesis. *J Cell Biol*, 169(6): 941–952
- Song M Y, Tian F F, Wang Y Z, Huang X, Guo J L, Ding D X (2015). Potential roles of the RGMa-FAK-Ras pathway in hippocampal mossy fiber sprouting in the pentylentetrazole kindling model. *Mol Med Rep*, 11(3): 1738–1744
- Suda T, Nakamura I, Jimi E, Takahashi N (1997). Regulation of osteoclast function. *J Bone Miner Res*, 12(6): 869–879
- Sulzmaier F J, Jean C, Schlaepfer D D (2014). FAK in cancer: mechanistic findings and clinical applications. *Nat Rev Cancer*, 14(9): 598–610
- Tavora B, Reynolds L E, Batista S, Demircioglu F, Fernandez I, Lechertier T, Lees D M, Wong P P, Alexopoulou A, Elia G, Clear A, Ledoux A, Hunter J, Perkins N, Gribben J G, Hodivala-Dilke K M (2014). Endothelial-cell FAK targeting sensitizes tumours to DNA-damaging therapy. *Nature*, 514(7520): 112–116
- Taylor J M, Mack C P, Nolan K, Regan C P, Owens G K, Parsons J T (2001). Selective expression of an endogenous inhibitor of FAK regulates proliferation and migration of vascular smooth muscle cells. *Mol Cell Biol*, 21(5): 1565–1572
- Taylor J M, Rovin J D, Parsons J T (2000). A role for focal adhesion kinase in phenylephrine-induced hypertrophy of rat ventricular cardiomyocytes. *J Biol Chem*, 275(25): 19250–19257
- Wendt M K, Schiemann B J, Parvani J G, Lee Y H, Kang Y, Schiemann W P (2013). TGF- β stimulates Pyk2 expression as part of an epithelial-mesenchymal transition program required for metastatic outgrowth of breast cancer. *Oncogene*, 32(16): 2005–2015
- Wynn T A (2011). Integrating mechanisms of pulmonary fibrosis. *J Exp Med*, 208(7): 1339–1350
- Xiong W C, Macklem M, Parsons J T (1998). Expression and characterization of splice variants of PYK2, a focal adhesion kinase-related protein. *J Cell Sci*, 111(Pt 14): 1981–1991

-
- Yoon H, Dehart J P, Murphy J M, Lim S T (2015). Understanding the roles of FAK in cancer: inhibitors, genetic models, and new insights. *J Histochem Cytochem*, 63(2): 114–128
- Zhao J, Guan J L (2009). Signal transduction by focal adhesion kinase in cancer. *Cancer Metastasis Rev*, 28(1-2): 35–49
- Zhou J, Aponte-Santamaría C, Sturm S, Bullerjahn J T, Bronowska A, Gräter F (2015). Mechanism of Focal Adhesion Kinase Mechanosensing. *PLOS Comput Biol*, 11(11): e1004593