

Supplementary Information

1 Principle of progressive gradient regression tree algorithm

The progressive gradient regression tree is one of the integrated algorithms, namely Boosting. Boosting is a method that can be used to improve the prediction accuracy of any weak classifier. It improves the accuracy of the prediction results by giving a series of the same or different weak classifiers a certain weight. The principle of the Boosting algorithm can be represented by Fig. S1. It can be seen that the Boosting algorithm first trains the first weak learner 1 with the weight given by each sample in the given training set, and updates the weight of the next training sample according to the learning error rate of the model. That is, increase the weight of the training samples with higher error rate in the weak learner 1, so that they will get more attention in the subsequent training model. Then train the weak learner 2 based on the training samples after adjusting the weights, repeat this process until the number of weak learners reaches the initial preset value N , and finally perform these N weak learners through different aggregation strategies Integration, get a mature and strong learner. The most widely used algorithm in the Boosting method is the progressive gradient regression tree algorithm.

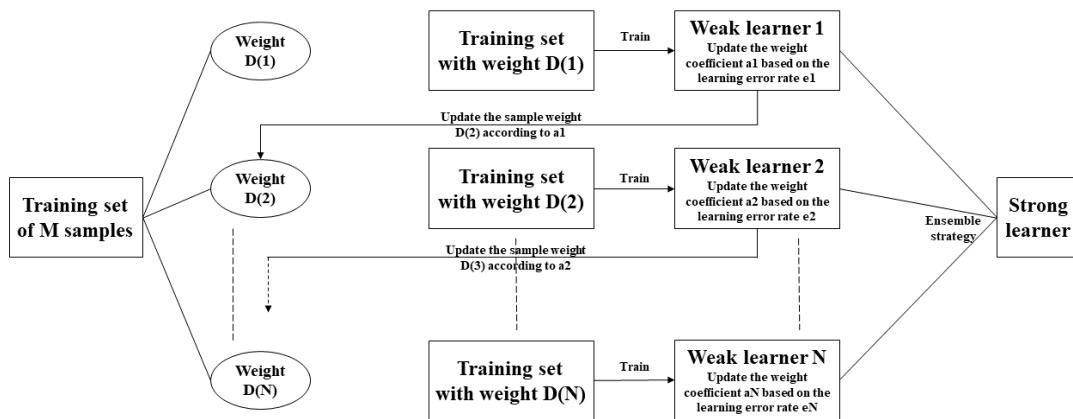

Fig. S1 Schematic diagram of Boosting algorithm

2 Parameters and the structure of the model

The maximum number of iterations of the weak learner's decision tree. The structure of the Gradient Boost Regression Tree model is shown in Fig. S2. When the number of iterations is too small, it is prone to under-fitting; when it is too large, it will over-fit. According to the empirical method, the best empirical value of the number of iterations in the Gradient Boosting Decision Tree is 100. When the sample size is greater than 2000, the number of iterations will be increased to obtain a better fitting result. Since the number of samples in this model is 1012, this parameter is selected as 100.

Determine the maximum depth of the decision tree. Since the number of characteristic variables in this study is 26 and the sample size is 1012, none of them are too large values. Therefore, like the random forest regression model, the choice does not limit the depth of a single decision tree.

The maximum number of features used by each tree. For the model using the Gradient Boosting Decision Tree, generally when there are many feature values, in order to control the generation time of the decision tree, the number of features included in each decision tree will be controlled within the “ $\log_2 n$ ” value of the total number of features, that is, when there are n characteristic variables, at most $\log_2 n$ are included in the modeling. Generally speaking, if the feature variable value is less than 50, consider not limiting the maximum number of features. At the same time, considering that the factors that affect the amount of municipal solid waste in actual life are more complicated, the model chooses not to limit the maximum number of features to fully consider the impact of various influencing factors on the amount of solid waste.

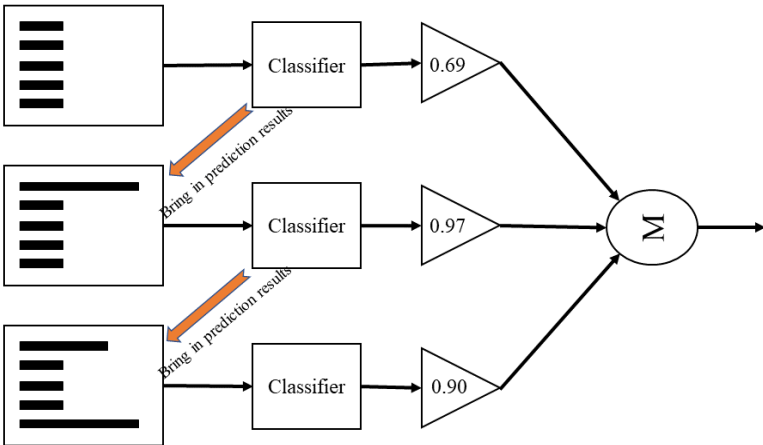

Fig. S2 The structure of the Gradient Boost Regression Tree model

For the WGMod model, the decision trees that make up the model are generated serially. After inputting the characteristic variables of the city, each decision tree will be iteratively calculated based on the prediction results of the previous number. After 100 iterations, a more accurate prediction result is finally obtained. The final output is the accumulated value of 100 decision trees. From a structural point of view, the asymptotic regression tree pays more attention to improving the prediction performance by reducing the deviation between the predicted value of the model and the true value. This may be the reason why its final accuracy is higher than other methods (such as random forest regression method).

3 Beijing and Shenzhen waste generation prediction parameters

To predict the amount of municipal waste generated in Shenzhen and Beijing in China, it is first necessary to collect the data of the input feature variables. And basic model parameters are shown in Table S1. By searching the city statistical yearbook, we obtained the data of the relevant feature variables of Shenzhen and Beijing in 2014–2018, and then we used them to predict the value of these variables in the five years of 2018–2022 by means of linear regression and least squares mathematical regression.

Take Shenzhen's permanent population as an example. Using the data of Shenzhen from 2014 to 2018 for linear fitting, a linear equation with a better fitting effect with R^2 of 0.999 was obtained in Fig. S3. And then we obtained other feature variables values with linear characteristics of Shenzhen and Beijing included Populations, Built-up area, Gross domestic product (GDP), Local fiscal revenue, Vegetable yield, Poultry meat production, Per capita disposable income, Average salary. Resident population density and per capita GDP were calculated by above results. For key factors that do not have linear characteristics like annual precipitation, annual average temperature and registered unemployment rate, we chose the estimation method based on the average of the past five years (Tables S2 and S3).

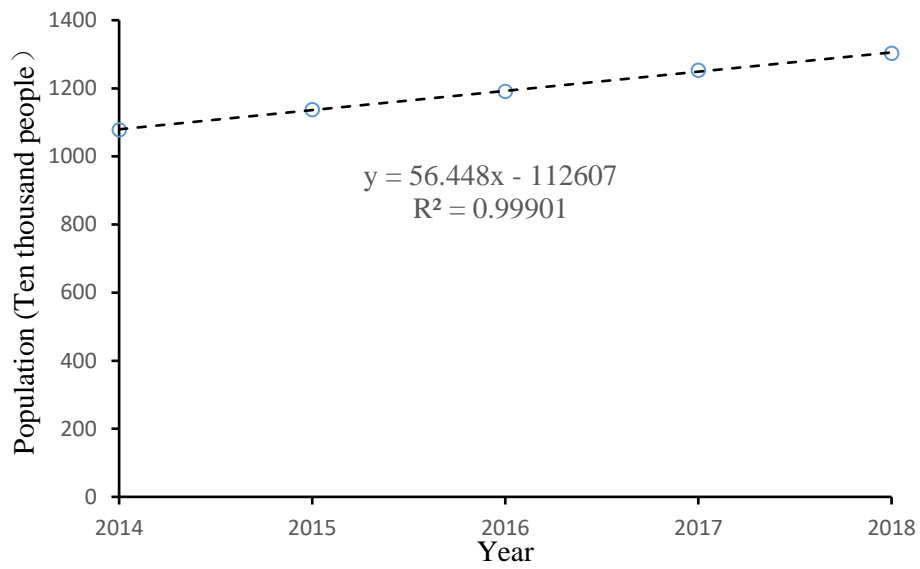

Fig. S3 Linear fitting of Shenzhen Population Growth Curve

Table S1 Model parameters

Parameter	Value
Learning rate	0.001
Maximum tree depth	20
Subsample feature	0.5
Boosting stages	100
Minimum early stopping	30

Table S2 Prediction values of socioeconomic key influencing factors in Shenzhen from 2018 to 2022

Feature variables	Unit	2018	2019	2020	2021	2022
Population	Ten thousand people	1361.51	1417.96	1474.41	1530.86	1587.30
Built-up area	Square kilometer	1081.2	1095.3	1117.3	1128.0	1142.3
Resident population density	Person per square kilometer	5398	5451	5614	5726	5841
Gross domestic product (GDP)	Billion	24681.8	25053.3	26305.9	28034.6	29616.9
Per capita GDP	Yuan	18.13	18.54	19.34	21.27	21.98
Local fiscal revenue	Billion	3791.2	3928.3	4163.2	4435.5	4657.2
Vegetable yield	Ton	15.87	16.66	18.14	21.03	22.88
Poultry meat production	Ton	7.74	8.23	8.78	9.02	9.92
Per capita disposable income	Ten thousand yuan	5.81	6.09	6.47	6.73	7.04
Average salary	Yuan	9349	9630	9879	10010	10317
Annual precipitation	Millimeter	1935.8	1967.1	1932.4	1920.1	1898.6
The annual average temperature	Celsius	23.0	23.0	23.1	23.1	23.0
Registered unemployment rate	%	2.26	2.26	2.24	2.25	2.24

Table S3 Prediction values of socioeconomic key influencing factors in Beijing from 2018 to 2022

Feature variables	Unit	2018	2019	2020	2021	2022
Population	Ten thousand people	2154.21	2165.64	2166.12	2166.60	2167.27
Built-up area	Square kilometer	1469.1	1487.8	1508.9	1530.1	1551.2
Resident population density	Person per square kilometer	1313	1320	1321	1323	1334
Gross domestic product (GDP)	Billion	33106.0	35181.6	37728.2	40274.4	42820.8
Per capita GDP	Yuan	15.37	26.65	28.56	30.44	32.10
Local fiscal revenue	Billion	5785.9	6287.5	6710.0	7132.4	7554.9
Vegetable yield	Ton	130.60	104.95	89.00	73.05	57.10
Poultry meat production	Ton	17.50	15.16	9.80	5.44	4.20
Per capita disposable income	Ten thousand yuan	6.34	6.64	7.08	7.53	7.97
Average salary	Yuan	149843	160139	171620	183101	194582
Annual precipitation	Millimeter	546.5	542.4	558.6	578.5	560.4
The annual average temperature	Celsius	13.6	13.9	13.8	13.9	13.9
Registered unemployment rate	%	1.40	1.39	1.40	1.41	1.41