

List of online supplemental material:

**Supplemental Fig. S1** - Eco-industrial network in the Guangxi Guigang eco-industrial park.

**Supplemental Fig. S2** - Eco-industrial network in the Xinjiang Shihezi eco-industrial park.

**Supplemental Fig. S3** - Eco-industrial network in the Kalundborg eco-industrial park.

**Supplemental Fig. S4** - Eco-industrial network in the Shandong Lubei eco-industrial park.

**Supplemental Fig. S5** - Eco-industrial network in the Choctaw eco-industrial park.

**Supplemental Fig. S6** - Eco-industrial network in the Kitakyushu eco-industrial park.

**Supplemental Fig. S7** - Eco-industrial network in the Tianjin TEDA eco-industrial park.

**Supplemental Fig. S8** - Eco-industrial network in the Styria eco-industrial park.

**Supplemental Text. S9** - Characteristics of the three types of network



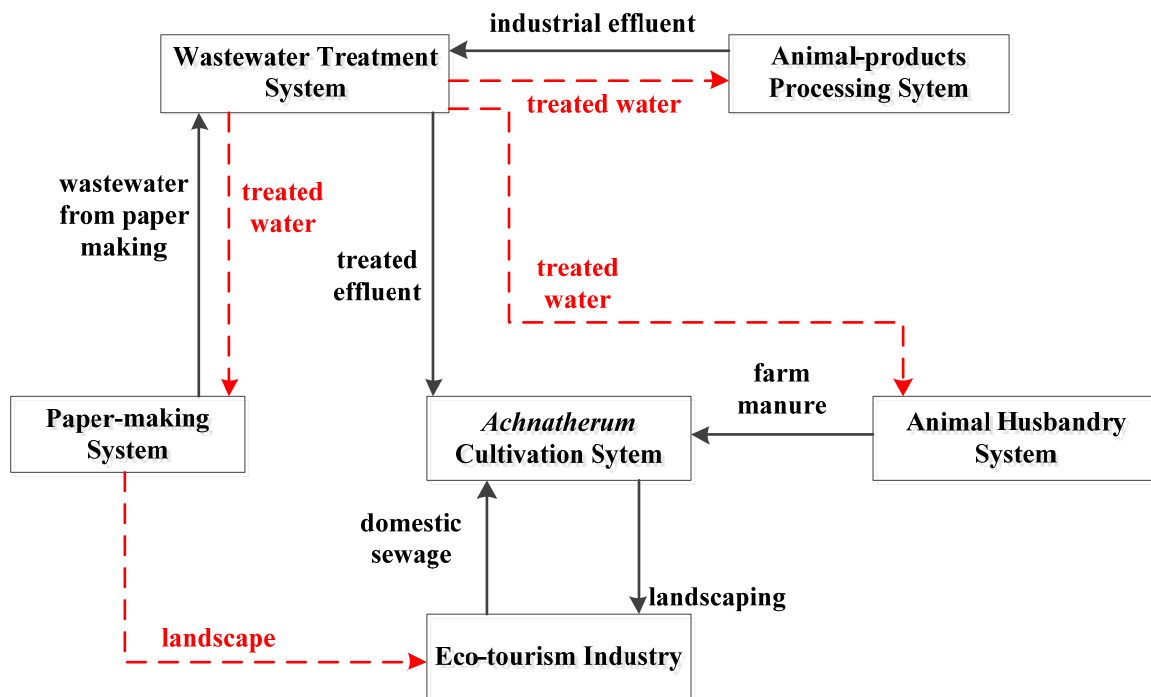

**Supplemental Fig. S2. Eco-industrial network in the Xinjiang Shihezi eco-industrial park.**

Note: dashed lines represent paths that can be established in the future.

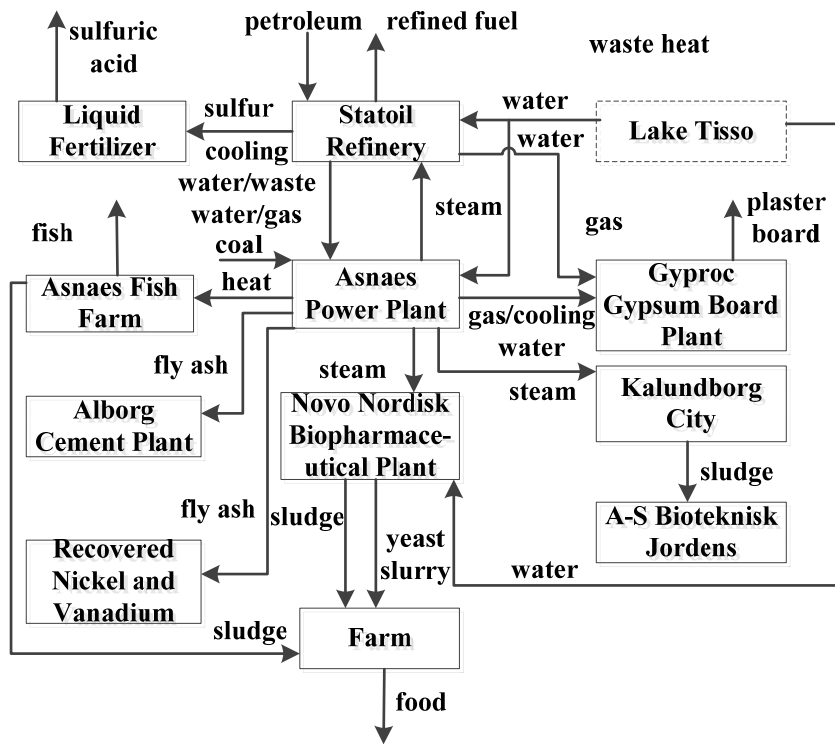

**Supplemental Fig. S3. Eco-industrial network in the Kalundborg eco-industrial park.**

Note: the rectangular box with dashed lines represents natural elements.

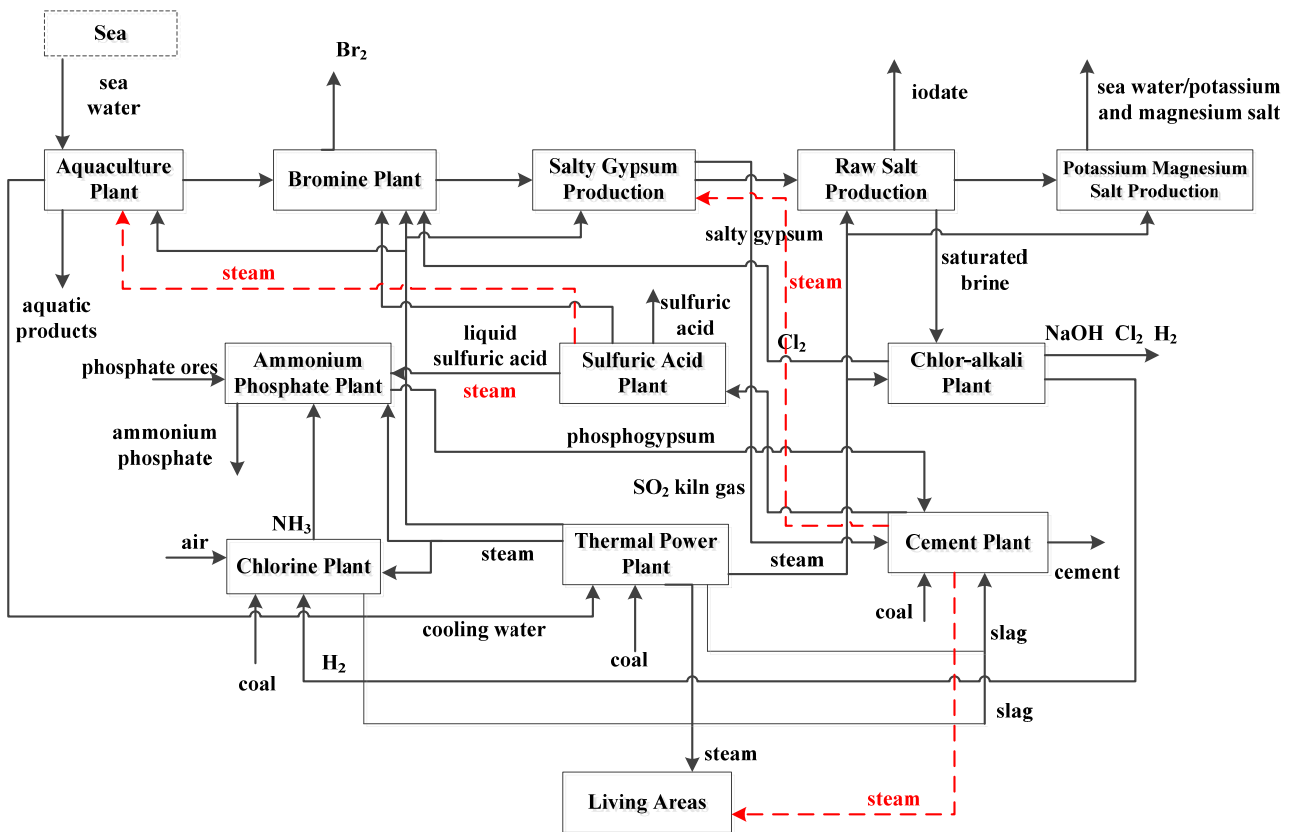

**Supplemental Fig. S4. Eco-industrial network in the Shandong Lubei eco-industrial park.**

Note: dashed lines represent paths that can be established in the future, and the rectangular box with dashed lines represents natural elements.

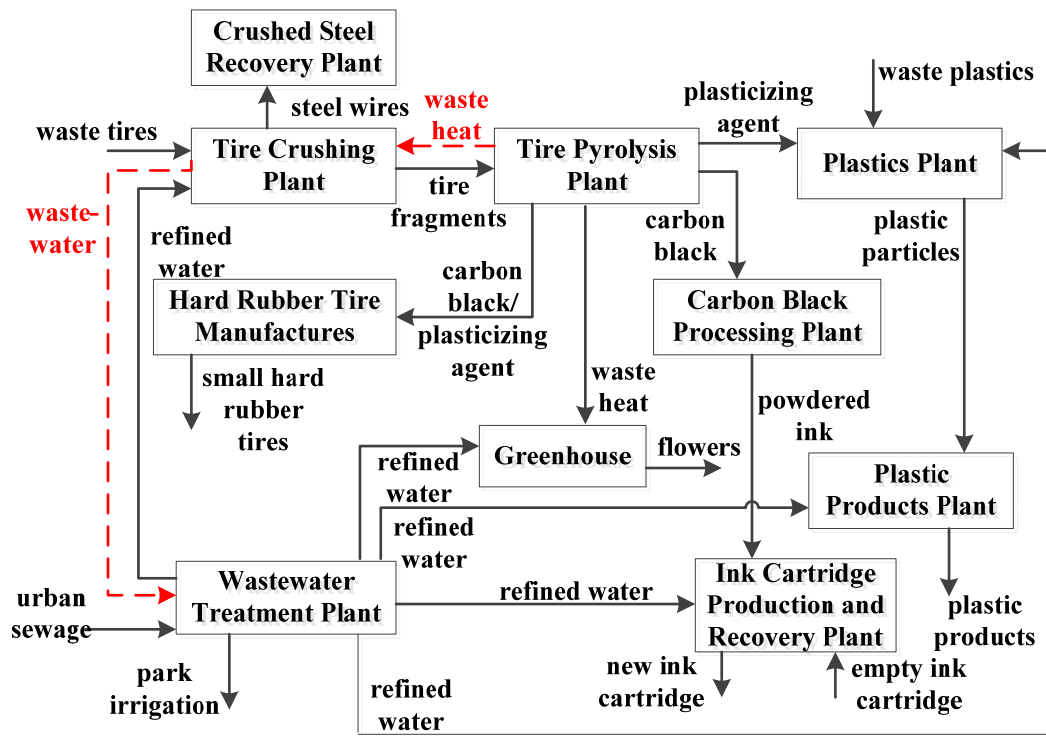

**Supplemental Fig. S5. Eco-industrial network in the Choctaw eco-industrial park.**

Note: dashed lines represent paths that can be established in the future.

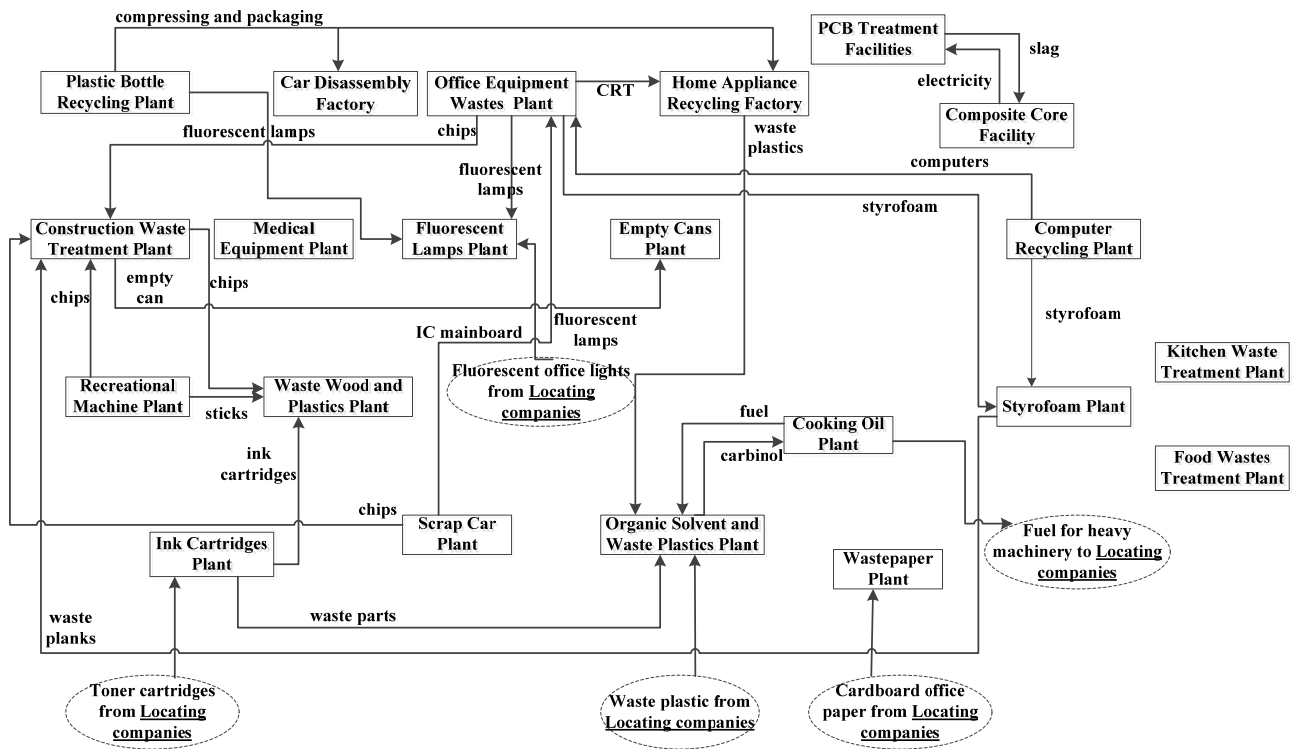

**Supplemental Fig. S6. Eco-industrial network in the Kitakyushu eco-industrial park.**

**"Locating companies" are companies that collect recyclable materials from the companies that produce them, and bring these materials to enterprises that can use them as inputs.**

Note: components circled with dashed lines represent reuse and recycling resources collected from companies located outside the park and transported to companies that are operating inside the park.

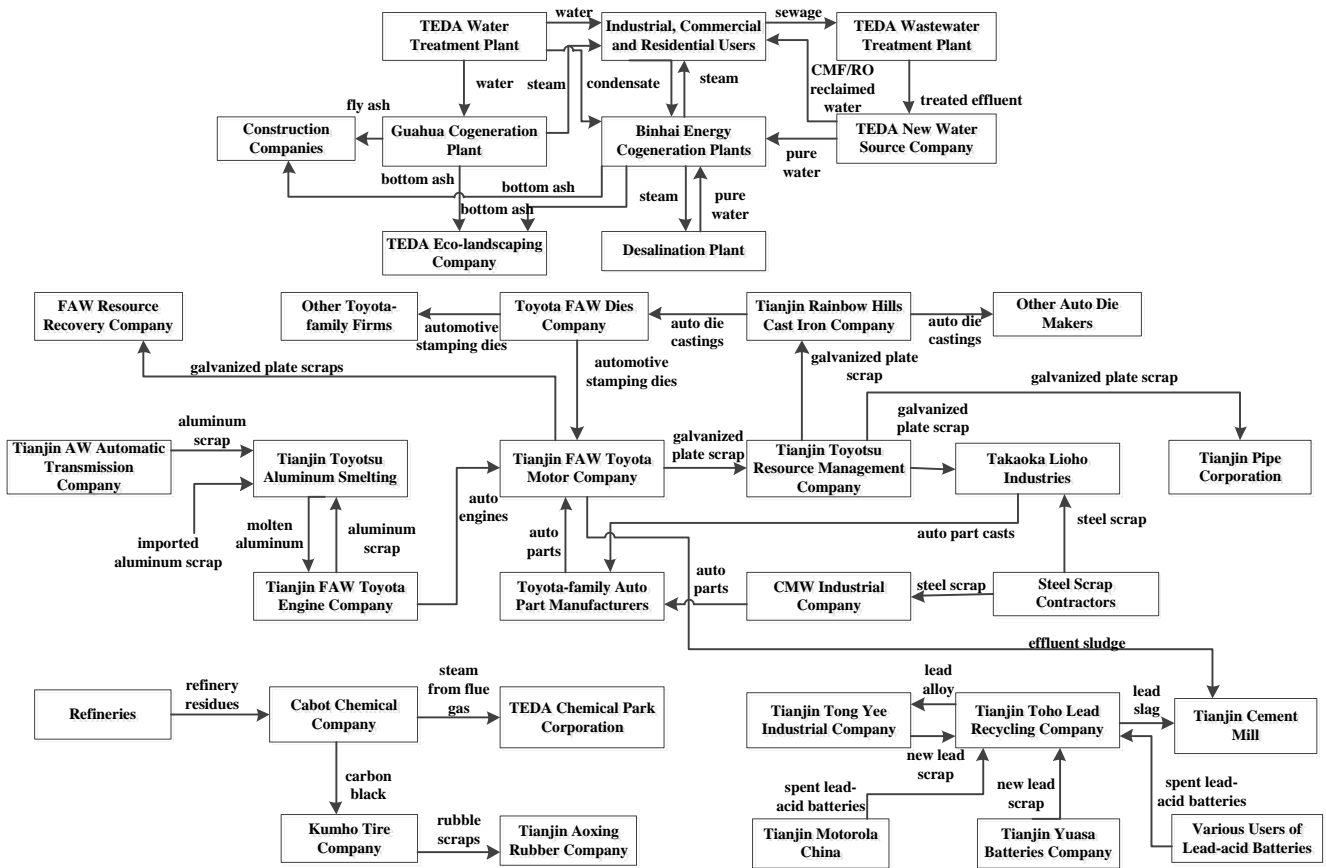

**Supplemental Fig. S7. Eco-industrial network in the Tianjin TEDA eco-industrial park.**

Note: CMF/RO water means water that was treated by adopting continuous micro-filtration pretreatment combined with a reverse-osmosis process for deionization.

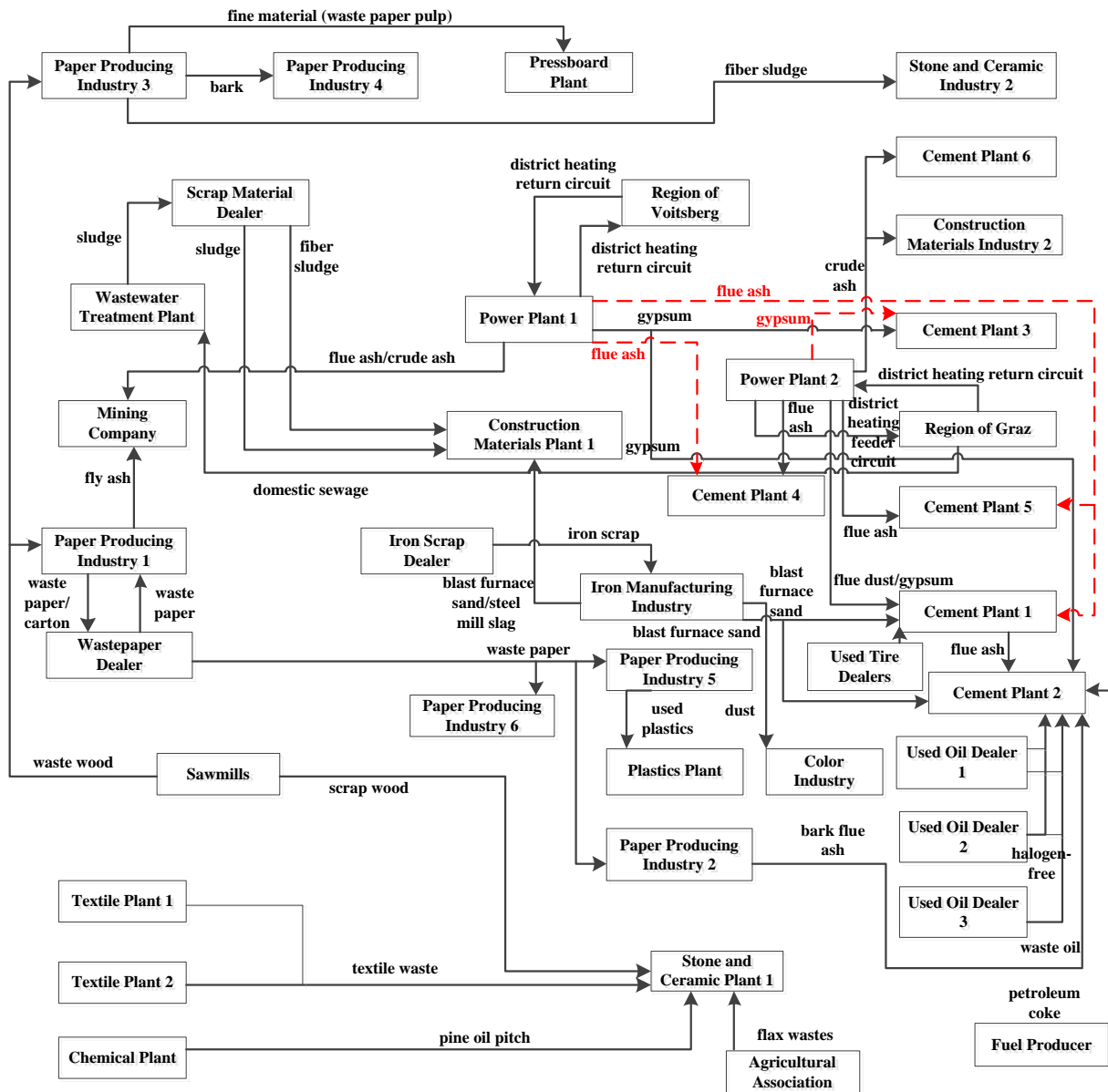

**Supplemental Fig. S8. Eco-industrial network in the Styria eco-industrial park.**

Note: dashed lines represent paths that can be established in the future.

## Supplemental Text S9. Characteristics of the three types of network

### “Anchor tenant” mutualism

In this type, different nodes have clearly different patterns of exchange, thus the network performance (the exchanges of materials and energy) differs among the nodes.

Figure 2a shows that in the Guangxi Guigang industrial symbiotic network, each node links to at least two other nodes. This means that the exchanges of resources occur among more members and at a large scale. This is also why the density of this network is the highest. Node 1 (the sugar refinery) serves as the core member and connects with the other six members to deliver and receive resources such as filter mud, blackstrap, scum, CO<sub>2</sub>, bagasse, and bagasse pith. To improve the functioning of this system, its managers should decrease the dependence on node 1 (the sugar refinery) and develop alternative enterprises to utilize its by-products or wastes. In addition, the role of some enterprises that engage in recycling or reuse of resources, such as the wastewater treatment plant, should be promoted.

Figure 2b shows that the Xinjiang Shihezi industrial symbiotic network has a core member (the *Achnatherum* cultivation system; node 1), and this node has relationships with all the other enterprises except the animal husbandry system, delivering “useless” resources to downstream members (nodes 2, 3, and 6) to reuse or recycle and receiving “resources” from upstream members (nodes 2, 3, 4, and 6) for its own use. The eco-tourism industry (node 6) is an industry based on visitors, and it exchanges intangible resources with the core member. This exchange places a lower demand on the core than would be the case for material exchanges. This is a key point, because it means that the eco-tourism industry can further develop its exchanges with other members without imposing a large ecological burden on the system.

In the Kalundborg network (Fig. 2c), the Asnaes power plant (node 4) is not only a core node that connects a large number of other enterprises, but also serves as an intermediate node that delivers resources. In contrast, five enterprises only receive resources from upstream members, and do not transfer resources to other nodes, even though they would inevitably produce wastes or by-products during their manufacturing processes; thus, it would be valuable to develop exchanges to allow reuse or recycling of these currently “useless” resources. There are some alternative linkages that can be developed to avoid the threat of wasting resources. This would help to decrease the dependence on core members and increase the stability of the network. For example, establishing connections between Kalundborg City and the farm would allow additional sludge produced by wastewater treatment in the city to be delivered to the farm as fertilizer.

### “Equality-oriented” mutualism

In the Shandong Lubei park (Fig. 2d), the resources tend to be gathered by the ammonium phosphate plant, cement plant, thermal power plant, chlorine plant, and bromine plant (nodes 1, 4, 5, and 7). That is, these members control more of the circulation of resources than the other enterprises. The relatively large number of core enterprises leads all the members to develop towards more equal relationships and to exchange resources more widely. In recent years, the park has implemented many new symbiotic linkages to improve its internal structure and improve its resource utilization efficiency. These new paths have not only improved the completeness of the network’s structure, but have also brought economic and social benefits. In section 4.3, we describe these changes in more detail.

Similar to the Shandong Lubei park, the Choctaw park (Fig. 2e) has several core nodes (the tire crushing plant, tire pyrolysis plant, plastics plant, and wastewater treatment plant; nodes 1, 2, 6, and 8) that tend to gather more resources than the other members. As the park focuses on reuse and recycling of resources, the nodes that can recycle resources, such as the tire crushing plant, the tire pyrolysis plant, and the wastewater treatment plant, play important roles in increasing the resource recovery efficiency and allowing the park to receive and process more wastes to some extent.

### Weak degree of completeness

Figure 2f shows that in the Kitakyushu industrial symbiotic network, four nodes (the medical equipment plant, wastepaper plant, kitchen waste treatment plant, and food wastes treatment plant; nodes 8, 19, 20, and 21) were not connected to other nodes, and were therefore isolated from the network. The connections between the PCB treatment facilities and the composite core facility result from exchanges of fly ash and electricity, and these nodes only exchange resources with each other. Apart from these nodes, the other nodes have established a complex network. Among them, the office equipment wastes plant serves as a core member at a small scale. It receives wastes from other enterprises and disassembles and recycles these wastes before delivering them to downstream members. This helps it to more fully recycle the network’s resources. In future development, the role of some recycling or reusing enterprises should be promoted. For example, of the isolated members, three represent reuse industries, and do not exchange resources with surrounding members. This may mean that some potentially reusable resources are not being fully utilized. This indicates that planning for the system’s development should attempt to develop exchanges of these resources in the future. In addition, it is necessary to enhance connections between the waste recycling and reuse enterprises and the other members. For example, the fluorescent lamps plant can collect more fluorescent lamps to recover the glass and other components, and the empty cans plant can extend its scale to collect more empty cans.

In the TEDA industrial symbiotic network (Fig. 2g), the exchanges among the nodes formed three sub-networks, plus two nodes that are isolated from the other nodes. In the sub-network formed by the refineries, the Cabot chemical company, Kumho tire company, and Tianjin Aoxing rubber company (nodes 25, 26, 31, and 32), there are no trends toward concentration of flows, and the resources were exchanged equally. In the smallest of the sub-networks, the industrial, commercial, and residential users (node 2) are at the core position, where they control more relationships than the other nodes. In the largest sub-network, the Tianjin FAW Toyota motor company and the Tianjin Toho lead recycling company (nodes 17 and 29) have established the most relationships with other nodes. If we consider the Tianjin cement mill (node 30) to be a node intermediate between these two, the sub-network can be further divided into two parts, one with the Tianjin Toho lead recycling company (node 29) as its center and forming a star network, and a second part in which the nodes are relatively equal. Similar to the Kitakyushu industrial symbiotic network, new symbiotic linkages should also be established in the TEDA park, especially for enterprises that engage in recycling or reusing metal resources.

In the Styria industrial symbiotic network (Fig. 2h), there are no isolated members. However, there are several core nodes in the network that define sub-networks. These include paper-producing industry 3, power plant 1, power plant 2, stone and ceramic plant 1, and cement plant 2 (nodes 1, 16, 23, 31, and 36). The nodes surrounding these core nodes formed a star structure. Furthermore, there are many enterprises in the same industry, such as six cement plants, six paper-producing industries, three used-oil dealers, two power plants, and two construction material plants. This redundancy is required by the large demand for the inputs and outputs of these enterprises. The diversity of these sources helps to ensure that the by-products and wastes of these enterprises are delivered to the downstream enterprises that use these resources, and this means that the downstream industries can resist any impacts that would result from changes in the production processes of any one of the upstream enterprises. This stability of downstream industries helps the upstream industries. This diversity can also help the system to fully utilize the by-products and wastes that the upstream industries deliver to these enterprises, and the upstream industries can better resist any impacts that would result from changes in any one of the downstream enterprises, leading to the disappearance of one user of their by-products and wastes.