

Wang XIANG, Peiyu MENG, Jinyu WEN

# Development and advances in modular multilevel converter based HVDC projects in China

© Higher Education Press 2023

**Keywords** high voltage direct current, power converter, power systems, renewable energy, ultra-high voltage

## 1 Introduction

To achieve the goal of carbon neutrality, promoting renewable energy integration has become an urgent priority for the green energy transition. Due to the geographical distribution of renewable energy bases, bulk electrical power is transmitted to load centers through long-distance transmission lines. The line-commutated converter (LCC) based high voltage direct current (HVDC) technology, emerging in the 1970s, is the most mature solution. In 2019, the Changji–Guquan ultra HVDC (UHVDC) project is commissioned in China, which transmits 12 GW power from Xinjiang region in northwest China, to Anhui province in eastern China, setting a new world record in terms of voltage level, transmission capacity and distance (Gou, 2019). However, LCC requires a solid alternating current (AC) voltage source for commutation, which makes it difficult to integrate weak AC networks. In addition, the commutation failure problem threatens the stable operation of power grids (Meng et al., 2022).

The modular multilevel converter (MMC) based HVDC technology possesses the merits of small footprint, self-commutation, and black start capabilities, which has led to a promising solution to the integration of renewable energy. In 2010, the Trans Bay Cable project is commissioned in the USA, which is the world's first MMC-HVDC project for commercial operation (Teeuwssen,

2011). From then on, MMC-HVDC technology has drawn significant attention. It is widely applied in offshore wind farm integration, remote renewable energy transmission and asynchronous AC network interconnection. Until now, more than 40 MMC-HVDC projects have been commissioned worldwide.

This paper will analyze state-of-the-art of the MMC-HVDC projects in China. Then, recent progress of three typical MMC-HVDC projects will be introduced in detail and the future trends of MMC-HVDC engineering applications will be discussed.

## 2 State-of-the-art of the MMC-HVDC

Figure 1 shows the typical power circuit of a three-phase MMC, which consists of six arms, with each arm comprising of series connected half-bridge submodules (HBSMs) and an arm inductor. Each phase-leg of the MMC comprises an upper arm and a lower arm (Xiang et al., 2022).

The HBSM is composed of two insulated gate bipolar transistor (IGBT) devices with antiparallel diodes and one direct current (DC) capacitor, as shown in Fig. 1. The

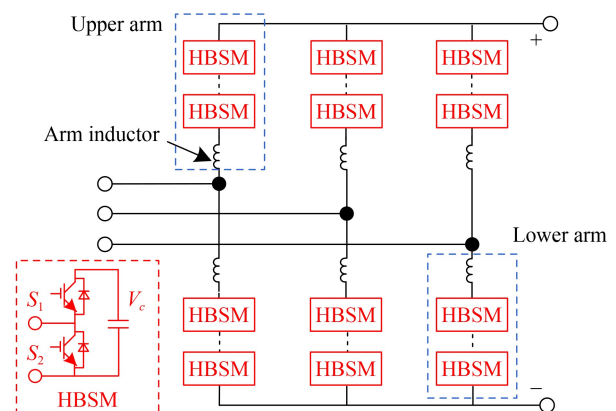

Fig. 1 Topology of the MMC.

Received November 28, 2022

Wang XIANG, Peiyu MENG, Jinyu WEN (✉)  
School of Electrical and Electronic Engineering, Huazhong University of Science and Technology, Wuhan 430074, China  
E-mail: jinyu.wen@hust.edu.cn

This work is sponsored by the National Natural Science Foundation of China (Grant No. 52237004).

HBSM has two switching states, namely, the bypass state and the insertion state. In the insertion state, the IGBT  $S_1$  is turned on and the IGBT  $S_2$  is turned off. The output voltage of HBSM equals the capacitor voltage ( $V_c$ ). In contrast, in the bypass state, the IGBT  $S_2$  is turned on and the IGBT  $S_1$  is turned off. Then, the output voltage of HBSM is zero. Thus, with the increase of the number of series-connected submodules (SMs), the number of levels of the terminal voltage increases. A string of  $N$  HBSMs can take values between zero and  $NV_c$  (i.e., a total of  $N + 1$  levels). In a high-voltage MMC, each arm can contain hundreds of SMs, which also enables significantly reduced harmonic contents due to the high number of voltage levels that can be used to resemble high-quality sinusoidal outputs.

Figure 2 shows the layout of a typical MMC station. It composes the AC yard, the DC yard, the valve hall, the control and protection devices, the cooling system, and other facilities (An et al., 2017).

The AC yard mainly consists of the start-up resistors, the interfacing transformers, the AC breakers, the arm inductors and measurement devices. The DC yard mainly consists of the DC smoothing reactor, arresters, measurement devices and DC switches. It should be noted that, for some overhead line transmission projects, the arm inductors are placed in the DC yard. The MMC and related facilities are placed in the valve hall, which is the core part of the MMC station. The AC/DC power conversation is realized in the valve hall.

The controller of MMC adopts the double vector control scheme, namely, the inner AC  $dq$  current control and the outer power/DC voltage control loops. The generic diagrams of the inner and outer controllers are depicted in Fig. 3. As seen, the outer controller that regulates the active power or DC voltage generates the  $d$ -axis current order whereas the outer controller that regulates the reactive power or AC voltage generates the  $q$ -axis current order. Recalling that in a multi-terminal HVDC

link, one converter terminal must control the DC voltage, and others must control active power. The inner current controller regulates  $dq$  currents and generates the AC modulating signals (phase and magnitude). In addition, to keep the energy balance among the three phases, the horizontal capacitor voltage balancing control can be adopted. Similarly, to keep the energy balance between the upper and lower arms, the vertical capacitor voltage balancing control can be designed (Leon and Amodeo, 2017).

### 3 Recent progress

In 2010, the State Grid Corporation of China constructed China's first MMC-HVDC project in Nanhui, Shanghai. After ten years of development, China has commissioned more than 10 MMC-HVDC projects, examples of which are depicted in Fig. 4. To date, the highest capacity of MMC converter station in China is  $\pm 800$  kV/5000 MW, which is adopted in the Longmen station of Kunliulong project. Different from the offshore wind power integration application in Europe, the MMC-HVDC projects are mainly used for long-distance transmission and asynchronous AC network interconnection in China.

For long-distance transmission using overhead lines, the MMC-HVDC technology faces the following challenges.

(1) The management of DC short circuit faults. Since the overhead lines are exposed to air, lightning and air pollution easily lead to short circuit faults on the transmission lines. When the MMC-HVDC system is subject to short circuit faults, all the SM capacitors discharge rapidly, resulting in a high fault current, which will jeopardize the converter.

(2) The requirement of high voltage and power ratings of converters. In China, there are many renewable energy bases at 10 GW scale. However, the MMC converter adopts the IGBT semiconductor. The conventional voltage

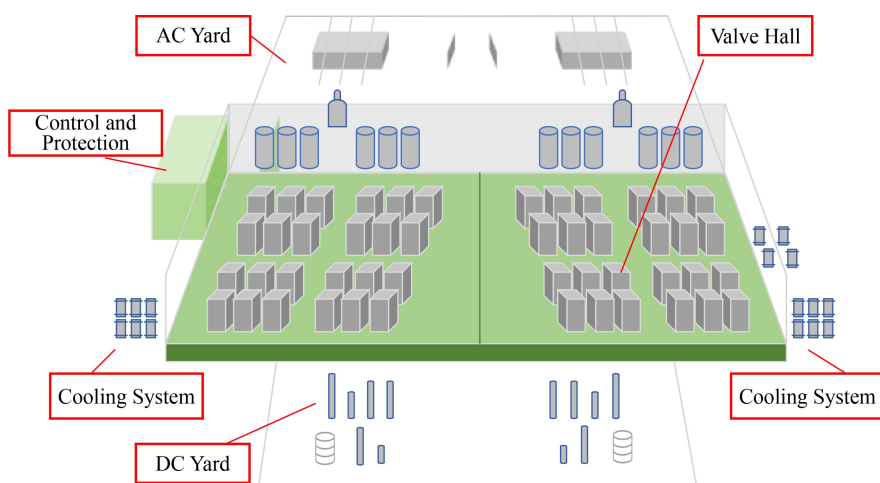

Fig. 2 Bird-view of an MMC station.

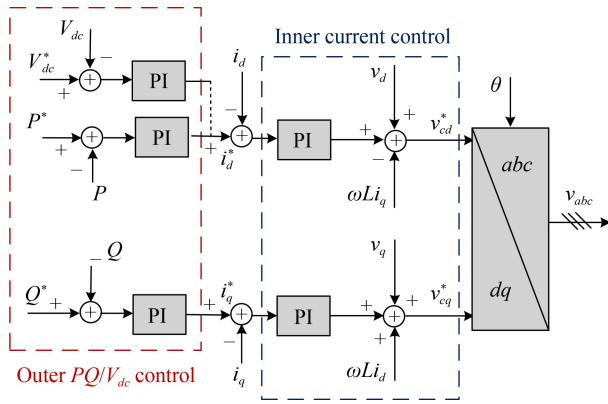

Fig. 3 Generic block diagram of the MMC controller.

and power ratings are  $\pm 320$  kV/900 MW. In contrast, the LCC converter adopts the thyristor semiconductor. Its conventional voltage and power ratings are  $\pm 800$  kV/8000 MW. Thus, the low ratings of MMC hamper its application in large-scale renewable energy transmission.

To overcome the above challenges, three world-famous MMC-HVDC projects are commissioned in China recently, including the Zhangbei project, the Kunliulong project and the Baihetan–Jiangsu project. Their features are summarized in Table 1 and the details of the three projects will be introduced in the following.

(a) Zhangbei HVDC grid project

Zhangbei area in Zhangjiakou is rich in wind and solar energy resources. However, the power demand of Zhangjiakou is small, while the adjacent Beijing–Tianjin–Hebei area needs a generous energy supply. The Zhangbei HVDC grid project integrates remote wind and solar energy from Zhangjiakou to Beijing load center through a bipolar meshed grid topology with 666 km overhead lines, ensuring the optimization of power flow.

This project has set many world-first records, mainly including:

- The world’s first four-terminal MMC-based DC grid.
- The world’s first large-scale islanded wind and photovoltaic power transmission with the bipolar configuration.

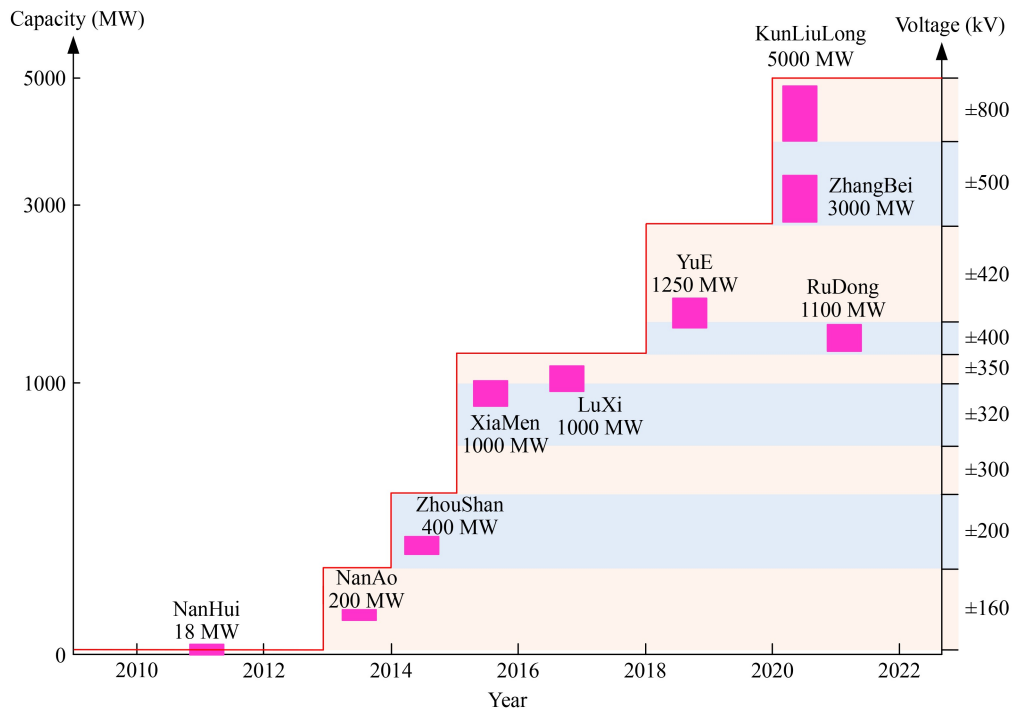

Fig. 4 Development of the MMC-HVDC stations in China.

Table 1 Features of the three world-famous MMC-HVDC projects in China

Projects	Features		
	Voltage	Power	Breakthroughs
Zhangbei	$\pm 500$ kV	3000 MW, 1500 MW	The world’s first HVDC grid project; The high power DC circuit breakers are first used
Kunliulong	$\pm 800$ kV	5000 MW, 3000 MW	The world’s first hybrid multi-terminal UHVDC project; The hybrid MMC is first used
Baihetan–Jiangsu	$\pm 800$ kV	8000 MW(with LCC)	The world’s first hybrid cascaded UHVDC project; The hybrid cascaded LCC-MMC converter is first used

- The world’s highest voltage level and largest capacity of a single MMC valve (500 kV/1500 MW).
- The world’s largest fully controlled device (4.5 kV/ 3 kA IGBT).

The system schematic diagram of the Zhangbei project is shown in Fig. 5.

Four ±500 kV converter stations have been built in Kangbao, Zhangbei, Fengning and Beijing, with a total capacity of 9000 MW. The parameters of each station are listed in Table 2 (Guo et al., 2020). To deal with the DC short circuit faults on the transmission lines, sixteen DC circuit breakers (DCCBs) are adopted, including the hybrid DCCB and the mechanical DCCB. To inhibit the fault current rise rate, 150 mH current limiting inductors are installed at the polar lines while 300 mH inductors are installed at the grounding lines. A 15 Ω grounding resistance is implemented at the Beijing station, and another 15 Ω grounding resistance is also implemented at the Fengning station for backup (Guo et al., 2021).

This project was commissioned in 2020. It can deliver about 14 billion kWh (14 TWh) of clean power to Beijing every year, which is about 1/10 of the annual power consumption in Beijing, and reduce 12.8 million tons of carbon dioxide emissions.

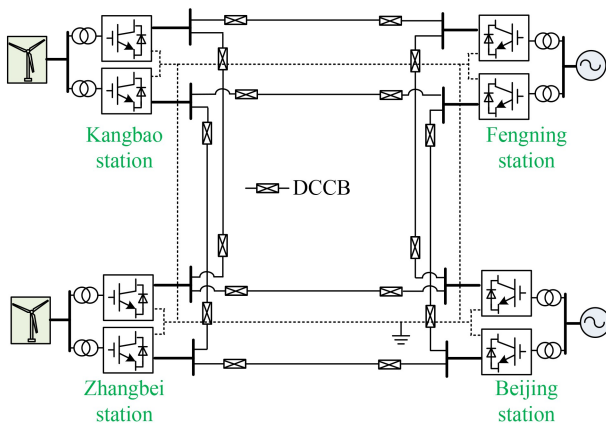

Fig. 5 System schematic diagram of Zhangbei project.

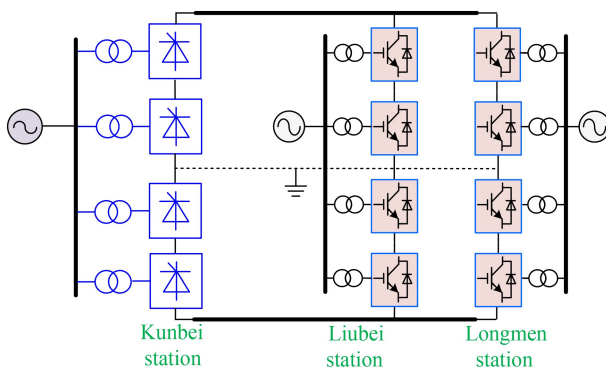

Fig. 6 System schematic diagram of Kunliulong UHVDC project.

(b) Kunliulong UHVDC project

The Kunliulong UHVDC project constructed by the China Southern Power Grid aims to transmit hydropower from the Wudongde hydropower station in Yunnan province to the Guangxi load center and Guangdong–Hong Kong–Macao Bay Area. This project spans four provinces, including Yunnan, Guizhou, Guangxi and Guangdong with a total length of 1489 km overhead lines, as shown in Fig. 6. The parameters of the three stations are listed in Table 3 (Rao et al., 2022).

This project has achieved multiple innovations in power grid technology and created a number of world-first records, mainly including:

- The first MMC-based UHVDC project in the world. The voltage rating of MMC reaches ±800 kV.
- The world’s largest capacity of a single MMC station (5000 MW).
- The first hybrid multi-terminal UHVDC project in the world, where the sending end Kunbei station adopts the LCC technology while the two receiving ends Liubei and Longmen stations adopt the MMC technology.
- The world’s first large capacity MMC-HVDC project with a transmission distance of more than 1000 km.

To cope with the DC short circuit faults on transmission lines, different from the DCCB approach in the Zhangbei project, the Kunliulong project adopts the hybrid MMC topology. Each arm of hybrid MMC consists of the full-bridge SMs (FBSMs) and HBSMs in series connection. The proportion of FBSM and HBSM on each arm is 70% : 30%. This is the first engineering application of hybrid MMC in the world.

Table 2 Parameters of the Zhangbei HVDC grid project

Value	Stations			
	Kangbao	Zhangbei	Fengning	Beijing
DC voltage	±500 kV	±500 kV	±500 kV	±500 kV
Rated power	1500 MW	3000 MW	1500 MW	3000 MW
SM capacitance	8 mF	15 mF	8 mF	15 mF
SM number	244	244	244	244
Arm inductance	100 mH	50 mH	100 mH	50 mH
Grounding resistance	/	/	15 Ω (for backup)	15 Ω

Table 3 Parameters of the Kunliulong UHVDC project

Value	Stations		
	Kunbei	Liubei	Longmen
DC voltage	±800 kV	±800 kV	±800 kV
Rated power	8000 MW	3000 MW	5000 MW
SM capacitance	/	18 mF	12 mF
SM number	/	60 HBSM + 140 FBSM	60 HBSM + 140 FBSM
Arm inductance	/	55 mH	40 mH
Grounding resistance	0.5989 Ω	2.6373 Ω	2.2954 Ω

The topology and the valve of the hybrid MMC in the Kunliulong project are shown in Figs. 7 and 8, respectively. Since the FBSMs are used, the hybrid MMC can

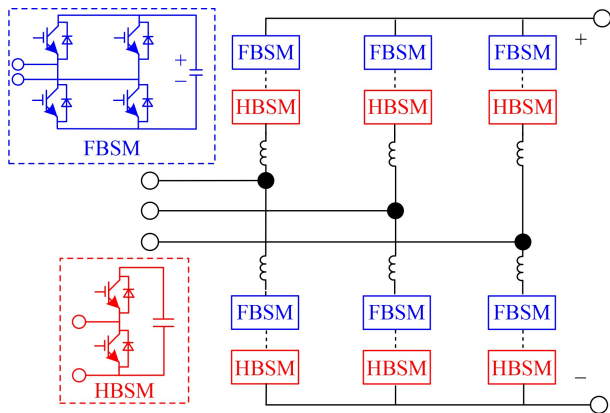

Fig. 7 Topology of the hybrid MMC.



Fig. 8 The hybrid MMC valve in Kunliulong project (Liubei station).

operate under zero DC voltage, enabling DC fault ride-through during DC short circuit faults. The DC fault self-clearing of MMC is realized for the first time.

The project was put into operation in 2020, and 33 TWh of clean hydropower has been transmitted annually, which is equivalent to reducing the consumption of standard coal by about 10 million tons and reducing the emissions of carbon dioxide by 26.6 million tons.

(c) Baihetan–Jiangsu hybrid cascaded UHVDC project

The Baihetan hydropower station, located at the border between Sichuan and Yunnan provinces, is the largest hydropower project under construction in the world, with a total installed capacity of 16 GW. With the economic and social development, the demand for electricity in Jiangsu province is increasing. The Baihetan–Jiangsu UHVDC project will transmit up to 8000 MW of electricity over more than 2000 km overhead lines. It starts at the Butuo station in Sichuan province, ends at the Changshu station in Jiangsu province, and passes through 5 provinces. The project uses LCC as the sending end, and the cascaded LCC and MMC hybrid converter as the receiving end. The topology of the hybrid cascaded converter is shown in Fig. 9. Each pole contains one LCC and three MMCs in parallel connection. The parameters of each station are listed in Table 4 (Li et al., 2022). To avoid transient overvoltage during AC grid faults, controllable self-recovery energy dissipation devices are paralleled with MMCs. This project alleviates the voltage stability risk caused by the reduction of thermal power plants in the East China Power Grid and improves the power receiving capacity of the East China Power Grid.

The Baihetan–Jiangsu project is the first hybrid cascaded UHVDC project in the world, taking advantages of LCC’s large capacity and low cost, and MMC’s flexible

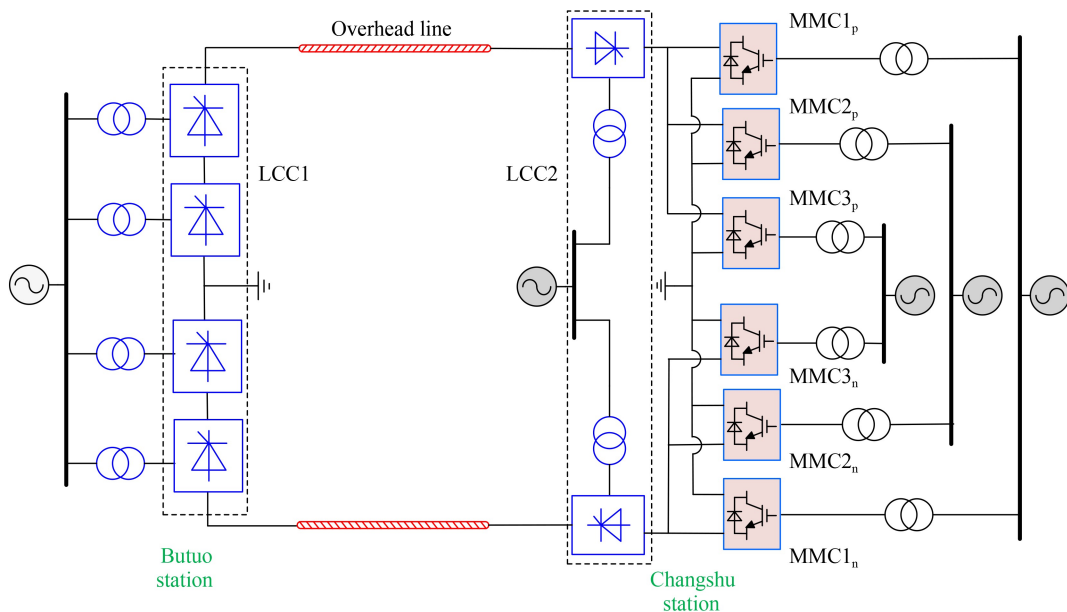

Fig. 9 Topology of the hybrid cascaded converter.

**Table 4** Parameters of the Baihetan–Jiangsu project

Value	Nodes				
	LCC1	LCC2	MMC1	MMC2	MMC3
DC voltage	±800 kV	±400 kV	±400 kV	±400 kV	±400 kV
Rated power	8000 MW	4000 MW	1334 MW	1334 MW	1334 MW
SM capacitance	/	/	16.67 mF	16.67 mF	16.67 mF
SM number	/	/	200	200	200
Arm inductance	/	/	25.3 mH	25.3 mH	25.3 mH

control and strong system support capability. This project was commissioned in 2022. Its annual power transmission will exceed 31 TWh, reducing the use of 14 million tons of standard coal and 25.4 million tons of carbon dioxide emissions every year.

#### 4 Future trends

With the increasing demand for renewable energy utilization, the MMC-HVDC technology will be further developed, especially for renewable energy transmission over long distances and offshore wind power integration.

(a) MMC-UHVDC system for high-altitude area application

In China, many large renewable energy bases are located in remote high-altitude areas, such as Tibet and Sichuan areas. Due to the terrain and environmental constraints, it is difficult to construct large-capacity converters and related equipment. The construction of upper and lower valves in different places is promising for the UHVDC construction in these areas. For instance, the Jinshang–Hubei UHVDC project under construction in China has adopted this station-division structure, as

shown in Fig. 10. Where the ±800 kV upper valves and ±400 kV lower valves are connected through 110 km overhead line. The construction cost and insulation demand of the converter can be greatly reduced by placing the lower valve in the high-altitude area.

(b) MMC-UHVDC system for ±800 kV/8000 MW power transmission

Due to the relatively low voltage and current ratings of current fully controllable semiconductors, the capacity of MMC-HVDC systems is still less than that of the LCC-HVDC systems. Until now, all the HVDC projects with a transmission capacity of more than 5000 MW adopt LCC technology at the sending end. However, with the large-scale integration of renewable energy such as wind power and photovoltaic in the desert, Gobi and desertification lands, the MMC rectifier should be adopted.

Therefore, multiple MMCs need to be connected in parallel for bulk power transmission. Figure 11 shows a typical UHVDC system with parallel MMCs, which can realize 8000 MW power transmission at ±800 kV. This topology is potential to be applied in large-scale renewable energy bases in southeast Tibet.

(c) ±500 kV/2000 MW bipolar offshore wind integration system

To meet the Net Zero 2050 target, the European Union has set an overall target of generating 300 GW of offshore wind by 2050. Recently, TenneT planned to construct three offshore wind power integration projects in Germany, i.e., BalWin1, BalWin2, and BalWin3 projects. These projects will transmit a total capacity of 6000 MW, where each 2000 MW project will offer more than twice the transmission capacity of the common 900 MW projects in Germany to date. Meanwhile, the power generation enterprises in China are also planning to construct a ±500 kV/2000 MW bipolar MMC-HVDC project.

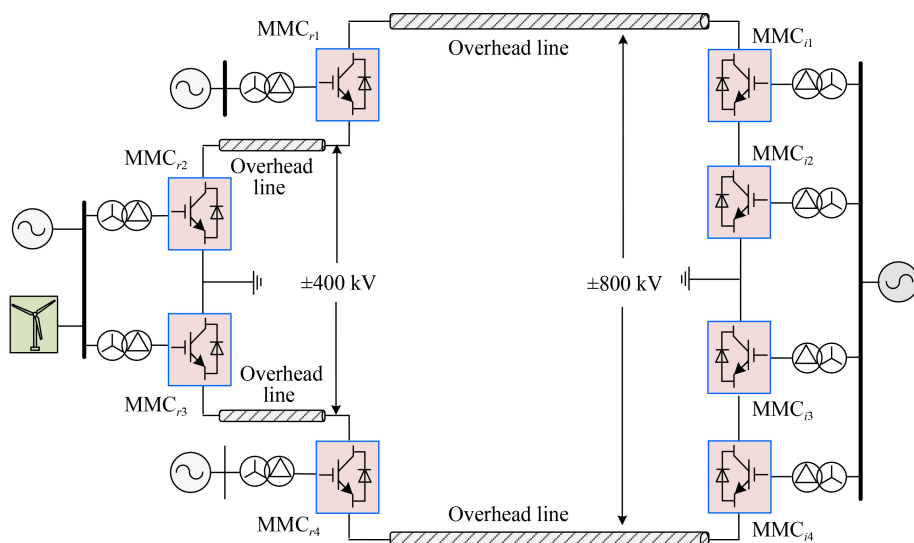

**Fig. 10** Topology of the station-division UHVDC for high-altitude application.

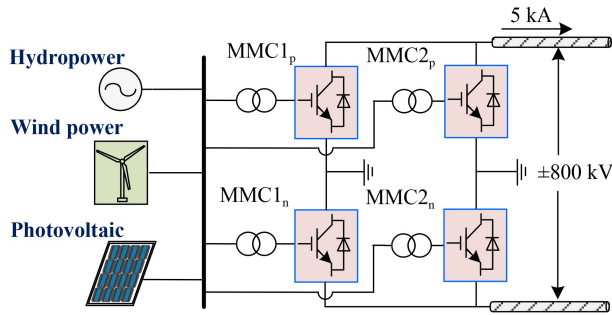

**Fig. 11** Topology of the UHVDC system with parallel MMCs.

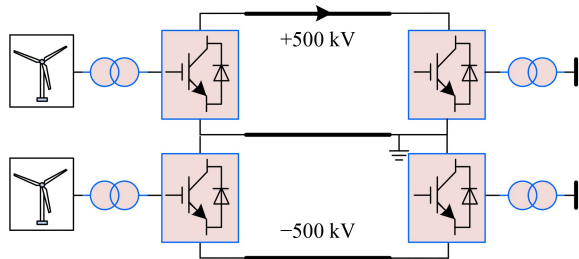

**Fig. 12** Topology of the bipole HVDC with the dedicated metallic return.

Different from that all existing offshore wind HVDC projects adopt the symmetrical monopole configuration, the  $\pm 500$  kV/2000 MW project uses two 500 kV (or 525 kV) export cables and one metallic return cable, forming a bipole HVDC configuration, as shown in Fig. 12 (TenneT, 2019). The metallic return cable is rated for continuous operation at the full DC current, whereas the voltage rating is much lower. Although the metallic return cable causes an increase in capital cost, it offers operational advantages, such as the highest availability.

## 5 Conclusions

In this paper, the development of MMC-HVDC projects in China is introduced. As seen, the engineering applications of MMC-HVDC in China develop very fast in the last decade, which set many world records in terms of transmission capacity, voltage level, transmission distance and converter topologies. Three typical HVDC projects are presented in detail, which are recently commissioned. At last, the station-division UHVDC,  $\pm 800$  kV/8000 MW UHVDC for bulk renewable energy

base long-distance transmission and  $\pm 500$  kV/2000 MW HVDC for offshore wind power integration are envisaged.

## References

- An T, Tang G, Wang W (2017). Research and application on multi-terminal and DC grids based on VSC-HVDC technology in China. *High Voltage*, 2(1): 1–10
- Gou R (2019). Research on 1100 kV/5500 A ultra-high voltage thyristor valve key technology and its application. *IEEE Transactions on Power Electronics*, 34(11): 10524–10533
- Guo M, Li X, Gao Z, Su G (2020). Simulation and analysis on stability improvement of Zhangbei renewable energy transmission via VSC-HVDC based on RTDS. In: *Proceedings of the 4th International Conference on HVDC*. Xi'an: IEEE, 299–303
- Guo M, Mei N, Li T, Yue B (2021). System design of  $\pm 500$  kV Zhangbei VSC-based DC grid project. *Power System Technology*, 45(10): 4194–4204 (in Chinese)
- Leon A E, Amodeo S J (2017). Energy balancing improvement of modular multilevel converters under unbalanced grid conditions. *IEEE Transactions on Power Electronics*, 32(8): 6628–6637
- Li X, Xu Z, Zhang Z (2022). Application of MMC with embedded energy storage for overvoltage suppression and fault ride-through improvement in series LCC-MMC hybrid HVDC system. *Journal of Modern Power Systems and Clean Energy*, in press, doi: 10.35833/MPCE.2021.000703
- Meng P, Xiang W, Chi Y, Wang Z, Lin W, Wen J (2022). Resilient DC voltage control for islanded wind farms integration using cascaded hybrid HVDC system. *IEEE Transactions on Power Systems*, 37(2): 1054–1066
- Rao H, Zou C, Xu S, Cai X, Li Y, Zhao X, Zhou Y, Yang Y, Wei W, Chen J, Wei T (2022). The on-site verification of key technologies for Kunbei–Liuzhou–Longmen hybrid multi-terminal ultra HVDC project. *CSEE Journal of Power and Energy Systems*, 8(5): 1281–1289
- Teeuwssen S P (2011). Modeling the Trans Bay Cable project as voltage-sourced converter with modular multilevel converter design. In: *Proceedings of the IEEE Power and Energy Society General Meeting*. Detroit, MI: IEEE, 1–8
- TenneT (2019). 2 GW HVDC grid design and reliability & availability. Online Report
- Xiang W, Yuan W, Xu L, Hodge E, Fitzgerald J, McKeever P, Bell K (2022). DC fault study of a point-to-point HVDC system integrating offshore wind farm using high-temperature superconductor DC cables. *IEEE Transactions on Energy Conversion*, 37(1): 377–388