

Improving neural sentence alignment with word translation

**Ying DING, Junhui LI, Zhengxian GONG, Guodong
ZHOU**

Frontiers of Computer Science, DOI: [10.1007/s11704-019-9164-3](https://doi.org/10.1007/s11704-019-9164-3)

Motivations

- Recent studies have shown sentence-level representation **fails to capture word alignment details** which are promising evidences for sentence alignment
- Recent studies have also shown that neural models still **fail to capture a large portion of word translation details**, even though it is capable of learning certain word translations from parallel corpus.
- In this paper, we address **how to explicitly incorporate word translation to enhance word distributed representation to improve sentence alignment performance.**

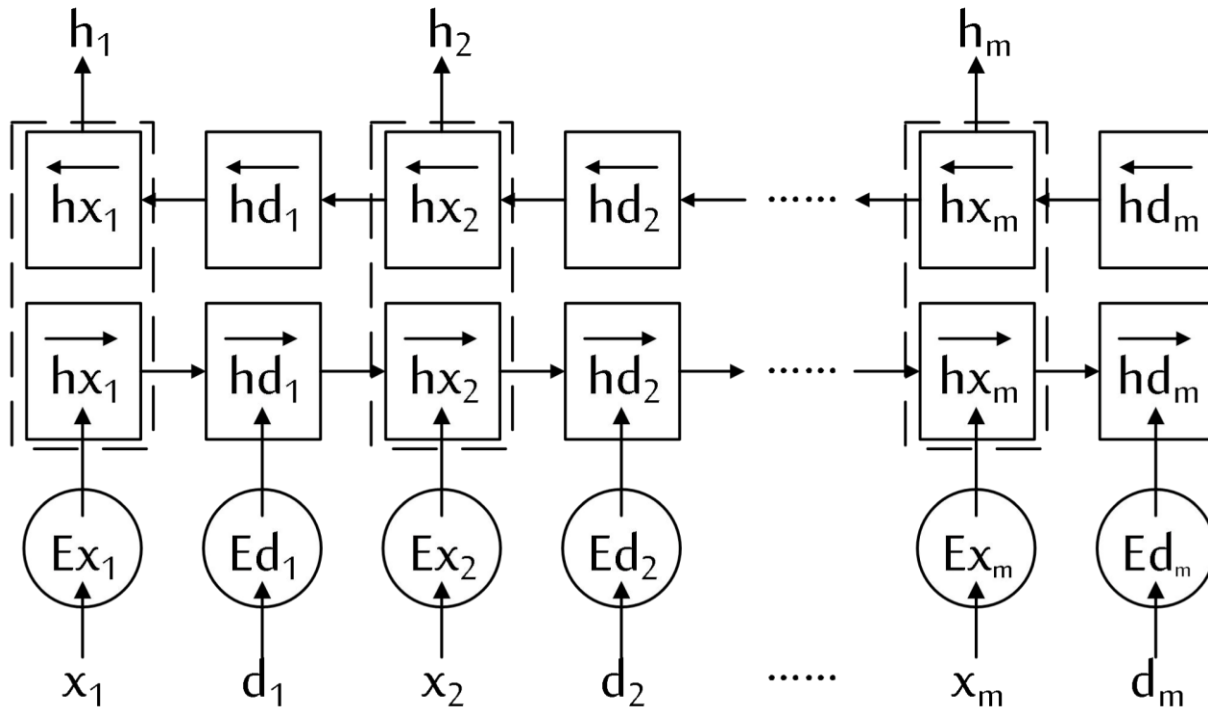

Mixed Encoder.

Here $(x_1 \dots x_m)$ is the input sentence while $(d_1 \dots d_m)$ is its word translation sequence.

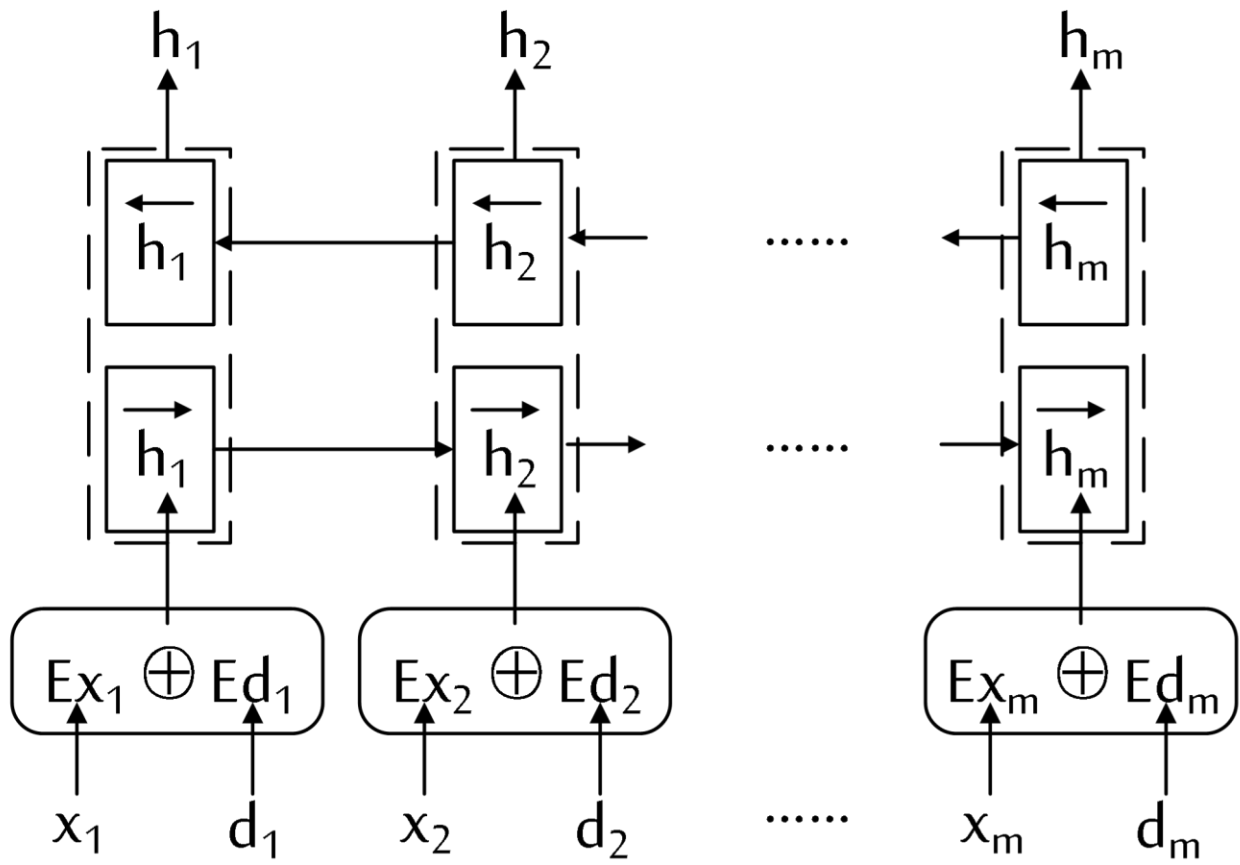

Factored Encoder.

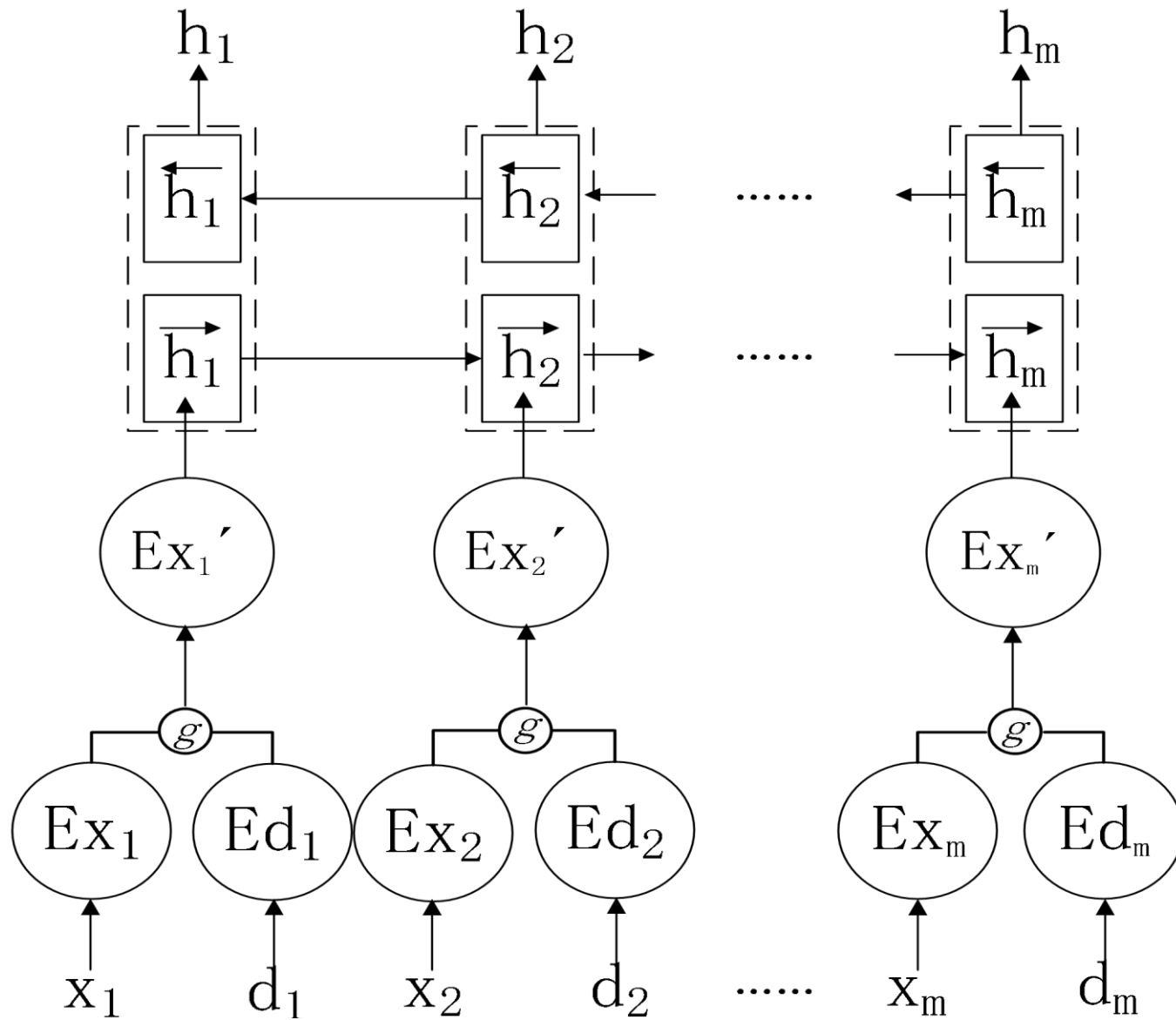

Gated Encoder.