

# Meta-BN Net for Few-Shot Learning

**Wei GAO, Mingwen SHAO, Jun SHU, Xinkai ZHUANG**

Frontiers of Computer Science, DOI: [10.1007/s11704-021-1237-4](https://doi.org/10.1007/s11704-021-1237-4)

# Problems & Ideas

- Problems of conventional few-shot learning approaches:
  - The unreliability of distribution statistics obtained from a small number of samples is not fully considered;
  - When the data distribution of training set and test set is quite different, the generalization performance of the model is poor.
- Ideas: Although the distribution within the learning process will be shifted causing poor performance of the model, we could correct this undesirable change adaptively according to the layer-wise output.

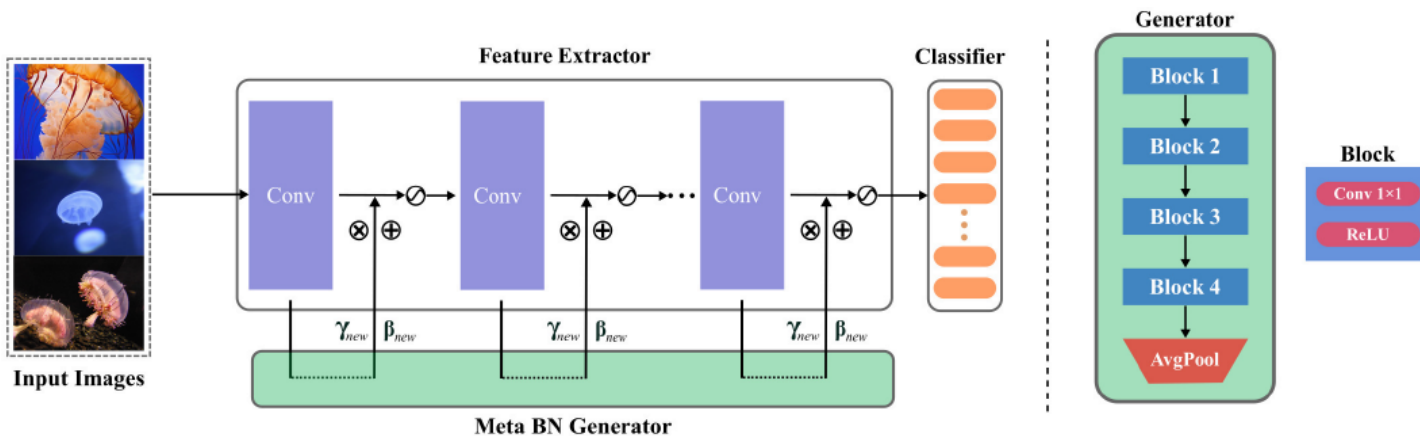

The architecture of Meta-BN Net (left) and the detail of Meta-BN Generator (right). For the output of each intermediate layer in the network, we use Meta-BN Generator to learn the distribution patterns of the few-sample features and generate adaptive affine transformation parameters for adjusting the feature distribution.

# Main Contributions

- Contributions:
  - A light-weight network, named Meta-BN Net, with an improved adaptive normalization module driven by meta-learning, which can effectively release the problem arisen from batch normalization when applies to the few-shot image classification task.;
  - By integrating the Meta-BN Net into basic networks,e.g. Conv-4, the performance of these networks are boosted significantly, even competitive with other much deeper networks or more complex algorithms;

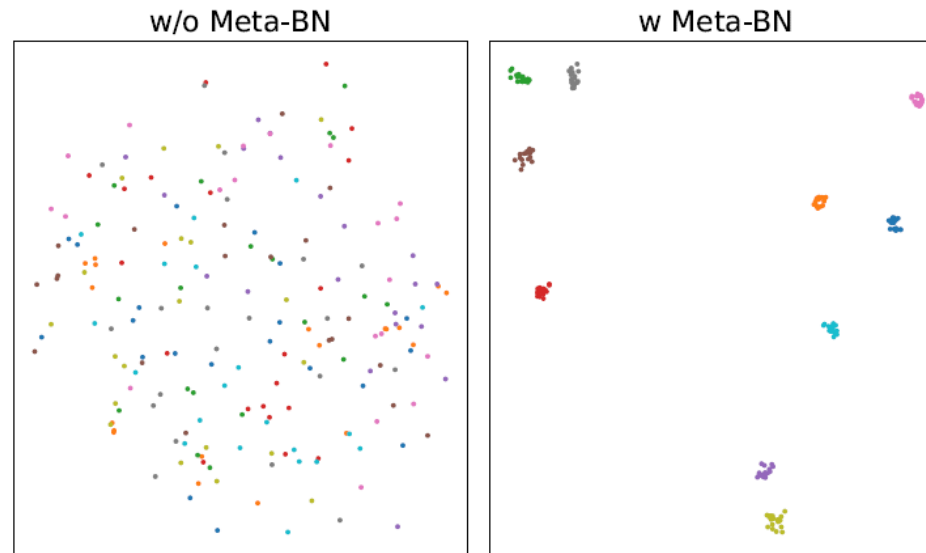

T-SNE visualization of the feature representation extracted from Meta-BN Net: without Meta-BN Generator (left) and with Meta-BN Generator (right).