

# A Search-Based Identification of Variable Microservices for Enterprise SaaS

**Sedigheh KHOSHNEVIS**

Frontiers of Computer Science, DOI: [10.1007/s11704-022-1390-4](https://doi.org/10.1007/s11704-022-1390-4)

# Problems & Ideas

- Problems of identifying microservices and their variability in SaaS
  - Designing microservice-based architecture is to find an appropriate partitioning of the system into microservices
  - For Enterprise SaaS the identification is preferred to be based on business processes
  - There is variability among various configurations of a SaaS due to its multiple tenants or multiple instances.
  - A set of criteria regarding given design metrics should be met.
  - Manual identification of such microservices is very costly and error-prone.

- Idea: Partitioning the graph of configurable process models using MOEA/D algorithm (SAMIM method)

- Each partition forms a microservice, for which the interface is designated
- Variability of micro services is then determined, forming a variable microservice architecture.

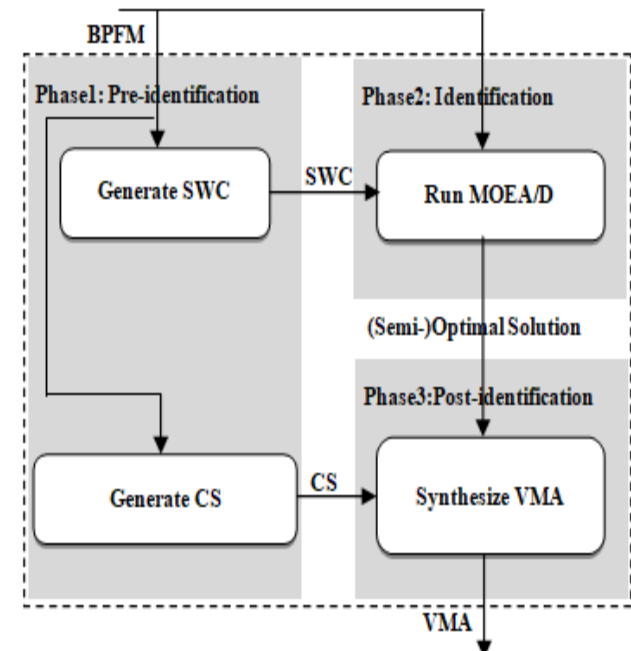

# Main Contributions

- **Empirical Evaluation over 6 cases, using GQM, engaging 27 out of 556 participants**
  - **A high similarity of objective metrics with experts' results (Scalar Similarity).**
  - **A rather high similarity of architecture structure with experts' results (Structural Similarity).**
  - **Full consistency**
  - **Improved degree of multi-tenancy (more tending to the goal 50% value)**
  - **A high in-space reusability degree**

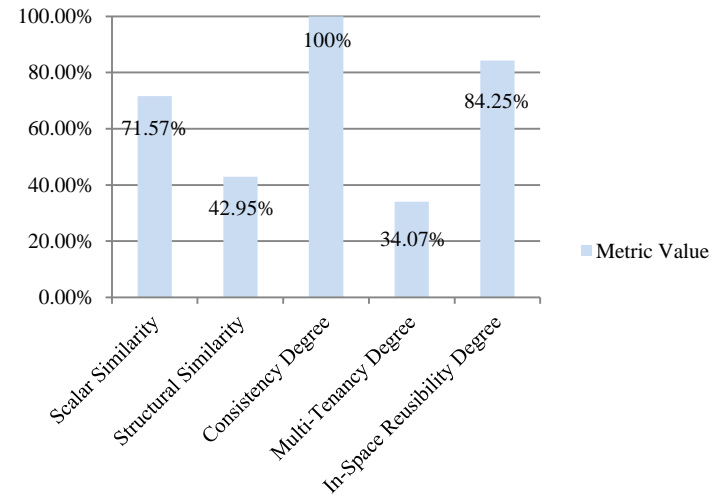

- **Improving business entity convergence, granularity and commonality compared with expert participants**

