

DiagDO: an efficient model based diagnosis approach with multiple observations

Huisi ZHOU, Dantong OUYANG, Xinliang TIAN,
Liming ZHANG

Frontiers of Computer Science, ID: 10.1007/s11704-022-2261-8

Problems & Ideas

- Problems of conventional MBD approaches:
 - Existing MBD algorithms with multiple observations ignore some observations that are consistent with system description.
- Ideas: Partitioning components into surely normal components and possible faulty components by analyzing pseudo normal observations and abnormal observations.

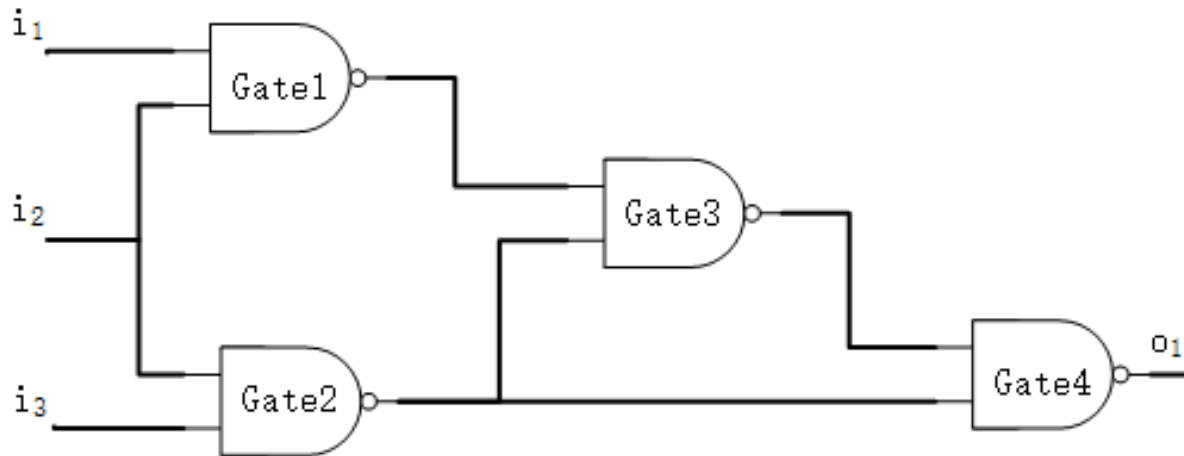

Given a pseudo normal observation $PNObs = \{i_1 = 0, i_2 = 1, i_3 = 1, o_1 = 1\}$, when inserting a single flipped fault into Gate2, the output of Gate2 is assigned value 0 by propagating the value of PNObs. As a result, the edge $\langle Gate1, Gate3 \rangle$ becomes fanin-free edges. Also, the edge $\langle Gate3, Gate4 \rangle$ becomes fanin-free edges. So Gate1 and Gate2 are surely normal components.

Main Contributions

- Contributions:
 - When inserting a single flipped fault into the circuit, we reason about a set of surely components and encode them into hard clauses;
 - By analysing the structure of the system, some dominated components are encoded into hard clauses, which reduces the solution space for computing a diagnosis.

Circuit	HSD		IHSD		DiagDO	
	#cardinality	#subset	#cardinality	#subset	#cardinality	#subset
	-minimal	-minimal	-minimal	-minimal	-minimal	-minimal
b14	1.87	1.79	1.67	1.63	1.55	1.52
b15	21.42	21.86	17.44	17.77	16.10	16.49
b17	151.36	155.30	119.04	118.74	119.46	118.53
b18	290.37	276.70	201.88	156.63	131.82	132.93
b19	271.37	274.71	243.10	262.92	219.52	202.12
b20	63.23	63.04	50.61	50.43	47.18	47.50
b21	64.45	63.47	51.87	51.27	48.58	48.08
b22	95.81	97.25	77.02	78.35	71.76	73.36

Circuit	HSD				DiagDO			
	#1	#5	#10	#15	#1	#5	#10	#15
	c432	0.0018	0.0095	0.0417	0.0196	0.0013	0.0013	0.0036
c499	0.0061	0.0234	0.1317	0.0659	0.0043	0.0043	0.0416	0.0043
c880	0.0033	0.0066	0.0169	0.0068	0.0016	0.0017	0.0065	0.0019
c1355	0.0226	0.0989	0.4023	0.1998	0.0082	0.0083	0.1905	0.0078
c1908	0.302	0.425	1.4314	0.6571	0.0161	0.0169	0.0481	0.1669
c2670	0.0307	0.0917	0.4908	0.2441	0.022	0.2274	0.0689	0.02294
c3540	0.0312	1.1744	5.5455	1.6556	0.0213	0.0216	0.1271	0.22
c5315	0.0627	0.7252	3.8817	1.147	0.0451	0.0453	0.132	0.045
c6288	16.5406	17.6502	20.5641	19.5629	1.4152	2.1187	20.5561	3.6791
c7552	0.1363	0.2082	0.6065	0.2081	0.0968	0.0974	0.2871	0.0973

Left: The total running time that all algorithms computes cardinality-minimal diagnoses when building on the ITC'99 benchmark; Right: The average running time that all algorithms computes subset-minimal diagnoses when building on the ISCAS'85 benchmark.