

Exploiting Comments Information to Improve Legal Public Opinion News Abstractive Summarization

Yuxin Huang, Zhengtao Yu, Yan Xiang, Zhiqiang Yu,
Junjun Guo

Frontiers of Computer Science, DOI: [10.1007/s11704-021-0561-z](https://doi.org/10.1007/s11704-021-0561-z)

Problems & Ideas

- Problems of abstractive summarization for legal-related news
 - how to effectively exploit the user comments to improve the performance of the LPO-news summarization task
- Ideas: Extract the case elements from the user comments
 - using a dual-channel selective denoising module to obtain the case elements from the noisy user comments
 - using a bi-directional attention module to construct the comment-aware context representation

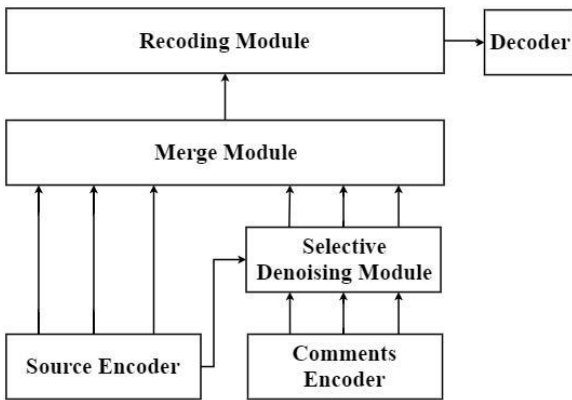

Fig.1 The framework of proposed model

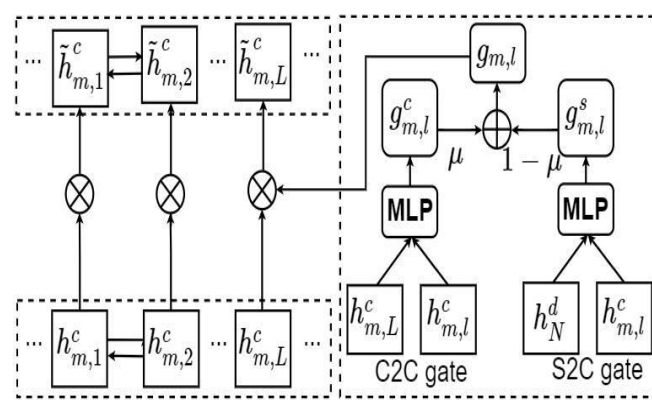

Fig.2 The dual-channel Selective denoising module

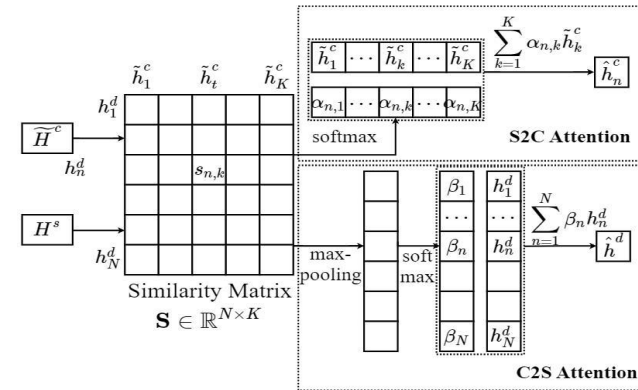

Fig.3 The bi-directional attention module

Main Contributions

- This paper proposes a user comments enhanced LPO-news abstractive summarization model to generate salient summaries by learning pivotal case elements from the comments.
- This paper presents a hierarchical comment-aware encoder (HCAE) to better model the source documents and the user comments.
- The experimental results on collected large-scale LPO-news corpus demonstrate that the HCAE model outperforms several SOTA models.

Models	RG-1	RG-2	RG-L
RA	28.15	11.85	27.01
SEASS	28.54	12.11	27.35
CGU	28.37	12.34	27.31
PG	29.99	12.39	27.90
KIGN	30.26	12.31	28.04
KCS	30.41	12.18	28.27
S2S_LSTM	27.85	11.71	26.34
S2S_Transformer	27.56	11.58	27.18
HCAE	30.80	12.66	28.60

Tab.1 The ROUGE score of different baselines

Models	RG-1	RG-2	RG-L
w/o Denosing	25.06	10.37	24.33
w/o Merging	21.65	7.72	19.19
w/o Recoding	28.65	11.79	27.81
HCAE	30.80	12.66	28.60

Tab.2 The ROUGE score of different ablation models