

Probabilistic Generative Model for Tracking Multi-Knowledge Concept Mastery Probability

Hengyu LIU, Tiancheng ZHANG, Fan LI, Minghe YU,
Ge YU

Frontiers of Computer Science, DOI: [10.1007/s11704-023-3008-x](https://doi.org/10.1007/s11704-023-3008-x)

Problems & Ideas

- Problems of Markov Chain-based Knowledge Tracing methods.
 - As the number of tracked knowledge concepts increases, the time complexity of MCKT increases exponentially.
 - Existing MCKT models only consider the relationship between knowledge status and problems, but ignore the relationship between knowledge concepts.
- Ideas: A joint model which contain both deep learning model and probabilistic generative model.
 - A probabilistic generative model is designed to better track knowledge status and better model students' exercise response.
 - A Long and Short-Term Memory (LSTM) is designed to approximate the posterior distribution of generative model to solve the high time complexity of generative model.

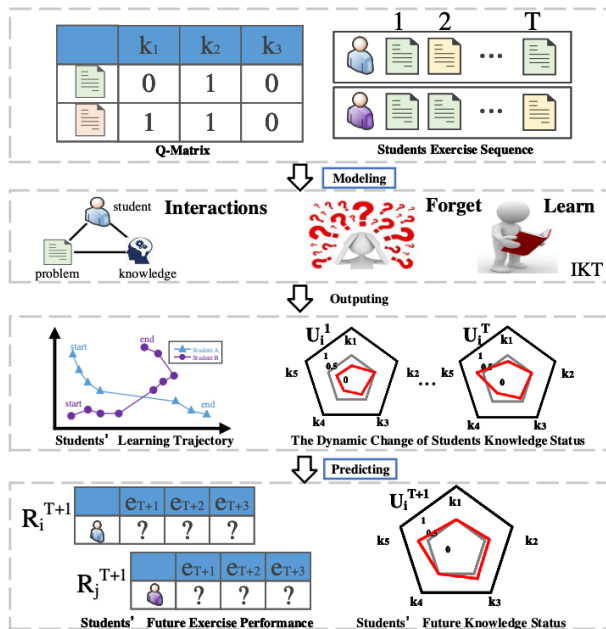

Fig. 2 The Framework of the TRACED model.

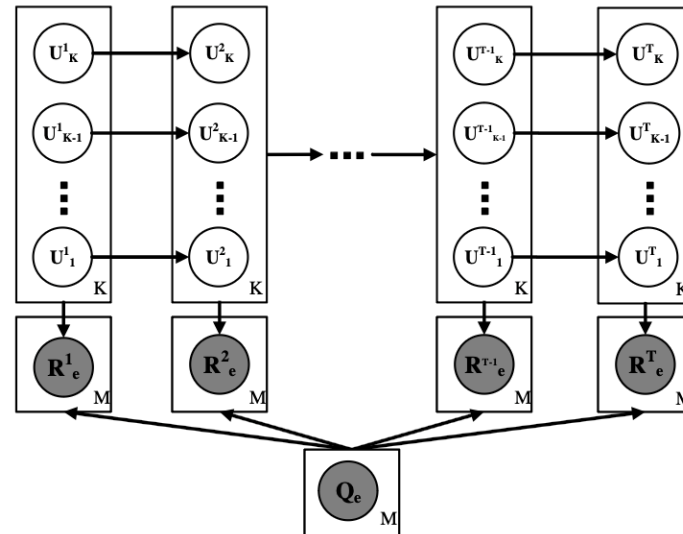

Fig. 3 Graphical representation of TRACED.

Main Contributions

- Contributions:
 - This is the first comprehensive attempt to track students' numerous knowledge concept mastery probabilities over time.
 - A logarithmic linear module with three interactive strategies is designed to model students' exercise responses by considering the relationship among knowledge status, concept and problems.
 - To solve the high time complexity, two LSTM-based networks is designed to approximate the posterior distribution and predict students' future performance, respectively.
 - A wake-sleep algorithm is proposed to train LSTMs and generative model jointly.

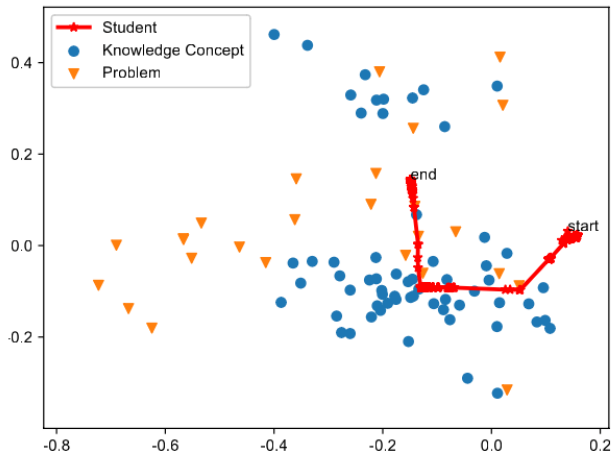

Fig. 6 Visualization of the learned distributed representations of students, knowledge concept and problem for the HDU dataset, where the learned representations have been reduced to 2 dimensions by means of PCA

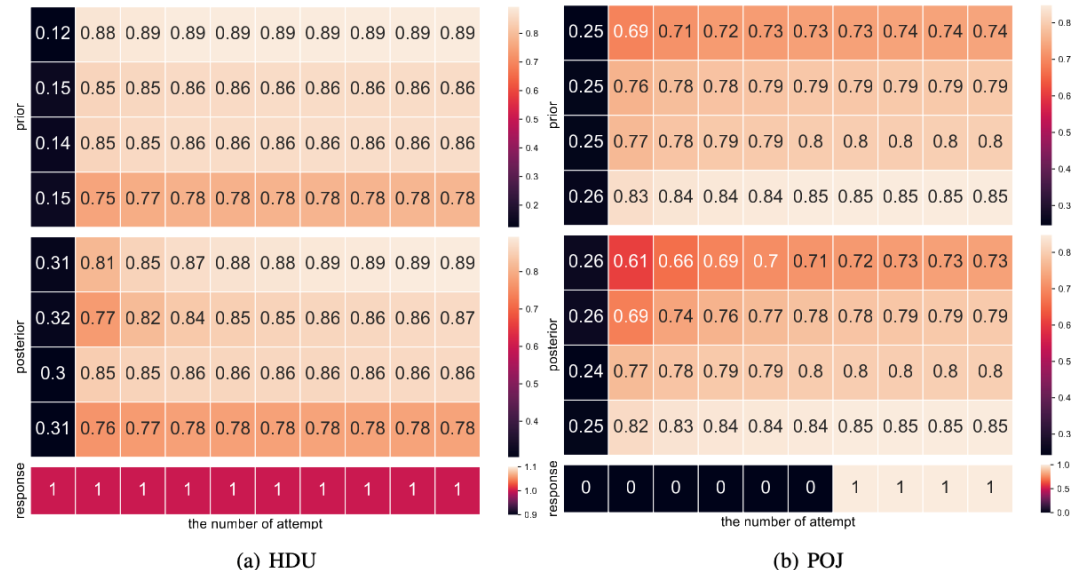

Fig. 5 The visualization of prior and posterior of TRACED on the HDU and POJ datasets