

Exact Acceleration of Subgraph Graph Neural Networks by Eliminating Computation Redundancy

**Qian TAO, Xiyuan WANG, Muhan ZHANG, Shuxian HU,
Wenyuan YU, Jingren ZHOU**

Frontiers of Computer Science, DOI: [10.1007/s11704-025-50471-4](https://doi.org/10.1007/s11704-025-50471-4)

Problems & Ideas

- Challenges of existing subgraph GNNs:
 - The generated subgraphs from the original graph structures result in a large consumption in storage.
 - Convolutions on the numerous subgraphs with size very close to the original graphs make a long time of training models.
- Ideas: Hidden embeddings of nodes in subgraphs share identical values based on their hops to the pivot nodes (i.e., the nodes whose structures or inputs are changed).

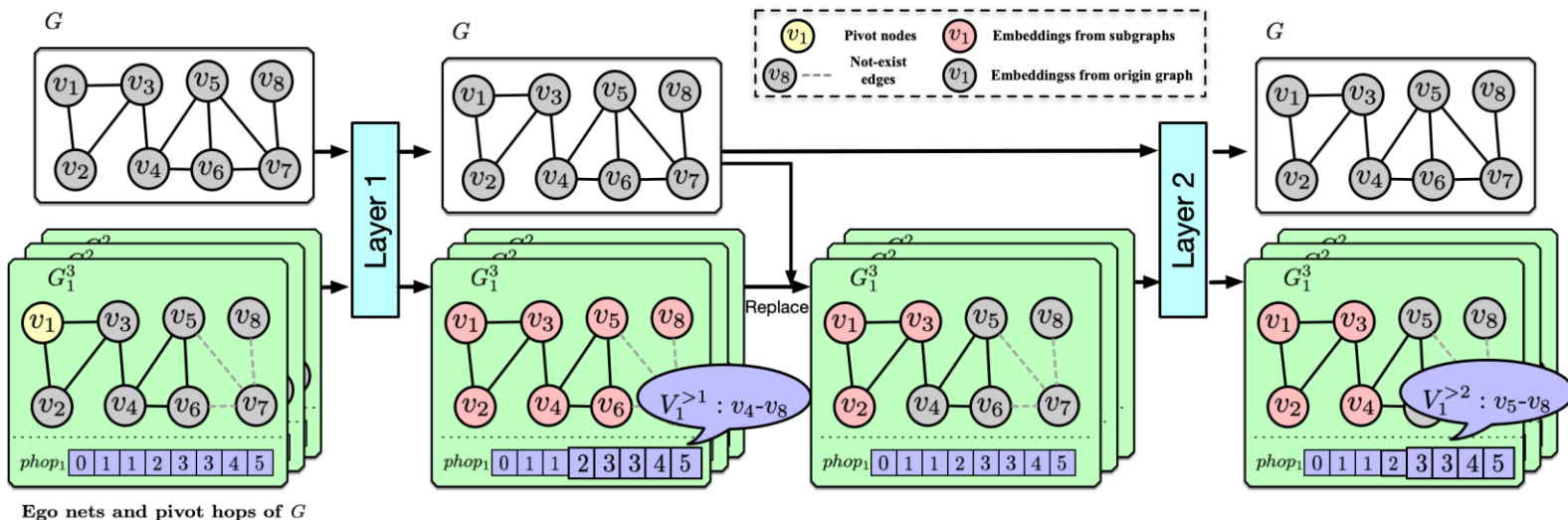

Pivot nodes: v_1 in G_1^3 ; pivot hops: hops to v_1 . In the i -th layer, the embeddings of those nodes with pivot hops $> i$ could be directly obtained from the convolution on original graphs.

Main Contributions

- Contributions:
 - A framework named ENFA is proposed, which takes the ego-nets as subgraphs while ensuring outputs identical to the subgraph GNNs under arbitrary subgraph construction strategies;
 - Discussion on the extension of ENFA to various subgraph policies and common variants, along with theoretical guarantees for exact acceleration;
 - Extensive experiments on various datasets to show the efficiency and effectiveness of ENFA.

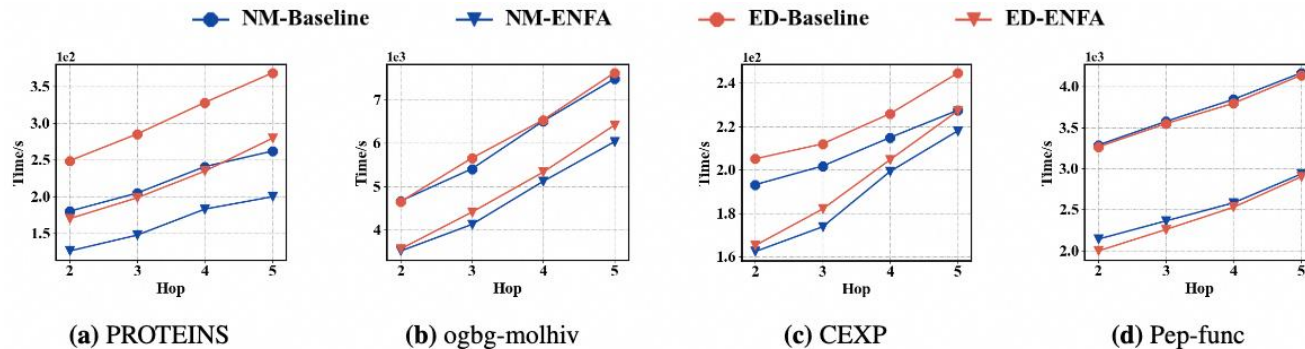

Datasets	Metric	node-marking		node-deleting		edge-deleting	
		ESAN	ENFA	ESAN	ENFA	ESAN	ENFA
PROTEINS	Accu.	76.9 \pm 3.9	77.0 \pm 4.8	77.1 \pm 4.6	76.6 \pm 4.3	76.8 \pm 4.6	76.6 \pm 3.7
molhiv	ROC	76.7 \pm 2.4	76.4 \pm 2.6	76.2 \pm 1.0	76.7 \pm 1.3	76.4 \pm 2.1	76.6 \pm 2.5
moltox21	ROC	75.5 \pm 1.2	75.7 \pm 0.8	75.8 \pm 0.3	75.2 \pm 0.7	75.1 \pm 0.5	75.6 \pm 1.0

Upper: ENFA takes less time for training a subgraph GNN; lower: ENFA contains close