

Towards Reliable Cross-Domain Recommendation: A Disentangled Global Graph Learning based Framework

**Pengyang SHAO, Zihan WANG, Junsong XIE,
Yonghui YANG, Meng WANG**

Frontiers of Computer Science, DOI: [10.1007/s11704-025-51176-4](https://doi.org/10.1007/s11704-025-51176-4)

Problems & Ideas

- Problems of current Cross-Domain recommendation (CDR) models
 - **Noise from imbalanced global graph interactions:** Directly aggregating global user–item interactions often introduces noise due to imbalanced data.
 - **Negative transfer due to poor disentanglement:** Fail to properly separate shared and domain-specific features, leading to entangled representations

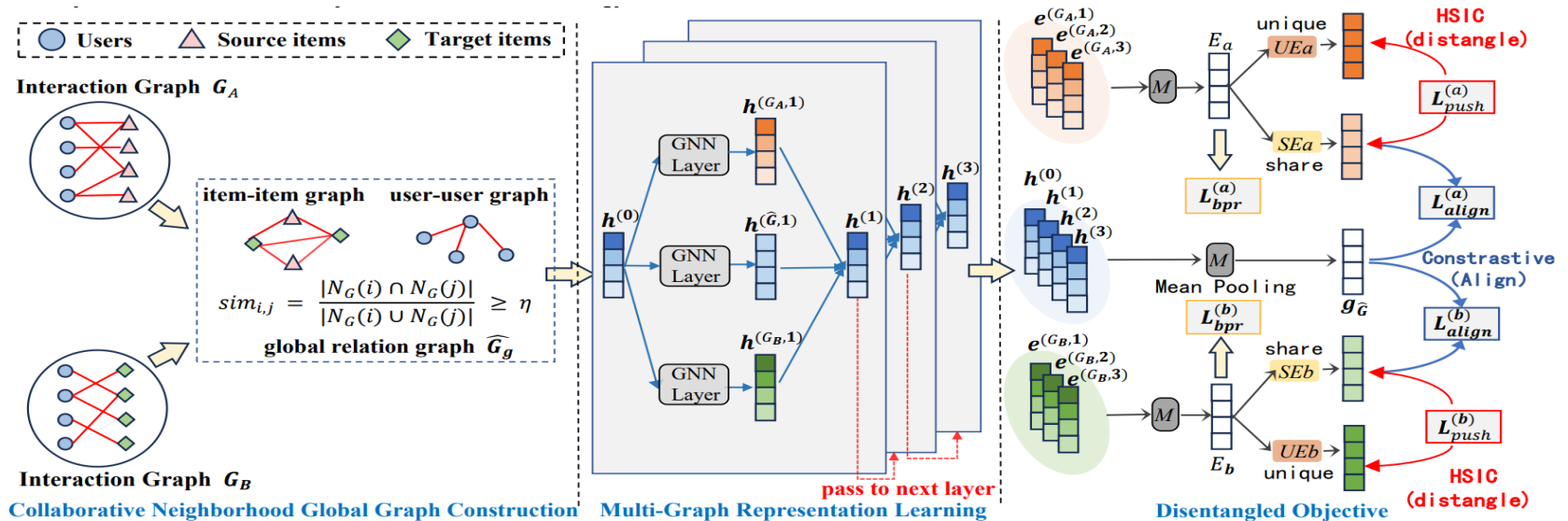

- Ideas:
 - Filtered collaborative neighborhood global graph and adaptive multi-graph propagation to capture comprehensive structural signals.

Main Contributions

- Contributions:
 - We identify key challenges in existing CDR methods, including noise from global aggregation and negative transfer from poor disentanglement.
 - We propose DiGC DR, a framework with global graph construction, multi-graph learning, and mutual information-based disentanglement.
 - Extensive experiments demonstrate that DiGC DR outperforms strong baselines and alleviates noise and negative transfer.

Table 1 Overall Performance Comparison on Three Cross-Domain Recommendation Tasks. **Bold** denote the best performance, and underline indicate the second-best performance.

Task	Domain	Metrics	Single domain methods			Cross domain methods						Ours
			MF	LightGCN	SimGCL	LightGCN-all	PTUPCDR	BiTGCF	DisenCDR	DRLCDR	DCCDR	
Task 1	Sport	Recall@20	0.0535	0.0660	0.0714	0.0690	0.0727	0.0687	0.0481	0.0501	<u>0.0741</u>	0.0764
		NDCG@20	0.0261	0.0326	0.0345	0.0344	0.0352	0.0324	0.0231	0.0241	<u>0.0363</u>	0.0372
	Phone	Recall@20	0.0743	0.0902	<u>0.1000</u>	0.0828	0.0835	0.0945	0.0715	0.0732	0.0985	0.1043
		NDCG@20	0.0332	0.0404	<u>0.0463</u>	0.0376	0.0363	0.0397	0.0302	0.0318	0.0459	0.0485
Task 2	Sport	Recall@20	0.0333	0.0512	0.0549	<u>0.1099</u>	0.0646	0.0961	0.0327	0.0501	0.0628	0.1202
		NDCG@20	0.0144	0.0229	0.0262	<u>0.0558</u>	0.0288	0.0513	0.0140	0.0252	0.0295	0.0684
	Cloth	Recall@20	0.0183	0.0389	0.0428	<u>0.1038</u>	0.0552	0.0960	0.0320	0.0412	0.0548	0.1204
		NDCG@20	0.0088	0.0182	0.0204	<u>0.0580</u>	0.0266	0.0571	0.0151	0.0206	0.0268	0.0701
Task 3	Elec	Recall@20	0.0044	0.0458	<u>0.0471</u>	0.0453	0.0416	0.0456	0.0405	0.0412	0.0439	0.0494
		NDCG@20	0.0055	0.0205	<u>0.0221</u>	0.0195	0.0172	0.0193	0.0174	0.0176	0.0183	0.0243
	Cloth	Recall@20	0.0136	0.0290	<u>0.0287</u>	0.0251	0.0202	0.0256	0.0224	0.0221	0.0247	0.0322
		NDCG@20	0.0061	0.0130	<u>0.0134</u>	0.0113	0.0090	0.0110	0.0097	0.0103	0.0106	0.0152

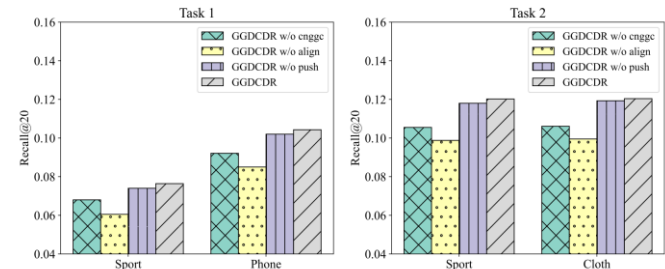

Fig. 2 Ablation study of *DiGC DR*.

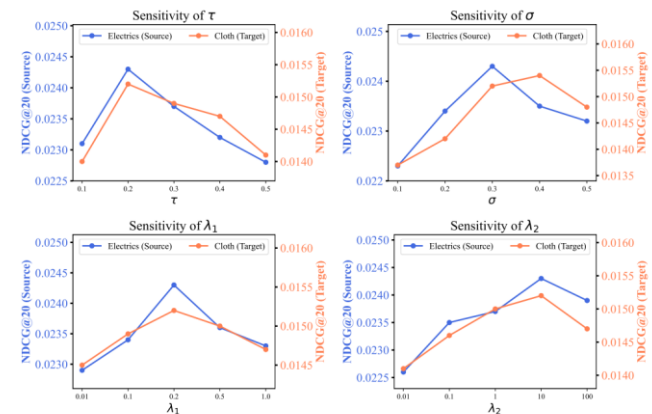

Fig. 3 Hyperparameter Sensitivity Analysis of *DiGC DR*.