

Optimization of a precision symmetric finger-clamping garlic seed-metering device

Qian ZHANG, Yongjian WANG, Hua LI (✉), Jifeng GAO, Yuangeng DING

College of Engineering, Nanjing Agricultural University, Nanjing 210031, China.

KEYWORDS

Garlic, precision seed-metering device, parameter optimization, symmetric finger-clamping device, DEM-MBD coupling

HIGHLIGHTS

- A precision symmetric finger-clamping garlic seed-metering device was designed.
- Influence of factors on the effectiveness of the seed-metering device was discovered.
- Seed-metering device met garlic seeding requirements after parameter optimization.

GRAPHICAL ABSTRACT

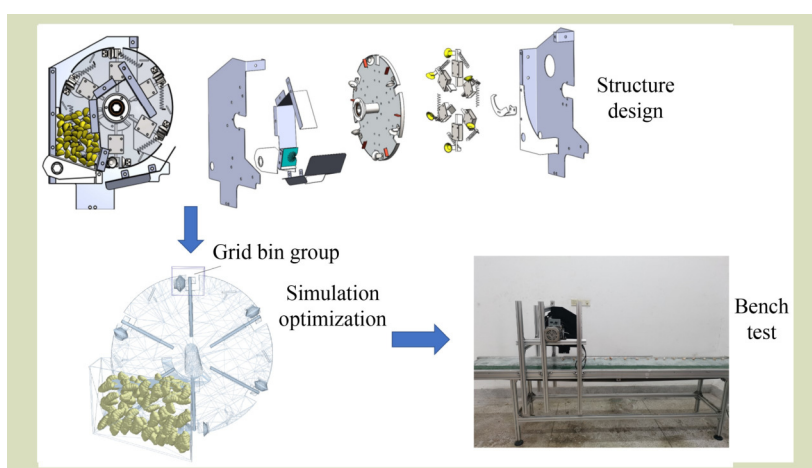

Received October 11, 2023;

Accepted February 26, 2024.

Correspondence: lihua@njau.edu.cn

ABSTRACT

This study aimed to address the sowing quality problems commonly encountered in the mechanized process of sowing garlic seeds, such as a low single-seed rate. To rectify these types of issues, the symmetric seed-collection spoons and the seed-distribution plate structures were designed based on an existing finger clip plate garlic seed-metering device. First, the optimal installation angle of the seed-distribution plate and optimal number of seed-collection spoons were determined using single-factor simulation tests based on discrete element method-multibody dynamics (DEM-MBD) coupling, and the effects of different seed-collection spoon tapers, finger clip gradual closing angles, and seed tray rotation speeds on the performance of the seed-metering device were analyzed. Second, based on the single-factor simulation tests, a quadratic regression orthogonal rotary combination simulation test was conducted using the taper of the seed-collection spoon, finger clip gradual closing angle, and seed tray rotation speed as the test factors and the single-seed rate (1 seed per spoon), empty rate (0 seed per spoon), and multiple-seed rate (≥ 2 seeds per spoon) as the test indices. Parameter optimization was performed using an established regression model. Finally, bench tests were conducted to verify the reliability of the simulation results. The results showed that the optimal parameter combinations were a seed-collection spoon taper of 1.6, a finger clip gradual closing angle of 21.4° , and a seed tray rotation speed of $31.5 \text{ r}\cdot\text{min}^{-1}$. Also, the seed-metering device exhibited a single-seed rate of 94.2%, an empty rate of 2.1%, and a multiple-seed rate of 3.7%.

1 Introduction

Garlic is an essential crop with both flavoring and medicinal properties as well as a high economic value^[1-5]. Although China has the largest garlic planting area and export volume globally, garlic planting in China is primarily performed manually^[6,7]. However, mechanized garlic seeding can overcome the problems associated with manual sowing, such as high intensity and low efficiency and simultaneously reduce production costs, which is conducive to promoting the development of the garlic industry. The seed-metering device, which is the core component of garlic-sowing machinery, is directly involved in the mechanized sowing of garlic seeds. In Europe and North America, the agronomy of garlic planting is simple, as the majority of farms use spoon-chain seed-metering devices^[8,9]. However, the agronomy of garlic planting in China requires single-seed sowing, and the prevalence of mechanized garlic sowing is low. Recently, the main seed-metering devices used in China have been the chain-spoon, pneumatic, and turntable types^[10,11].

Many scholars have conducted studies on garlic seed-metering devices. For example, Geng et al.^[8] proposed a new seeding method using a garlic seed box; however, it leaked severely during operations and required manual replenishment. In addition, Hou et al.^[12] developed a 2BSZ-12 garlic seeder using a claw-type cycle single-seed extraction device, which effectively reduced the empty rate. Also, Li et al.^[13] designed a wheel-and-spoon single-seed discharge device with a simple structure and high single-seed rate. Additionally, Hou et al.^[14] designed a double-filled garlic single-seed-metering chamber device using a first- and second-level seed-collection spoon tandem arrangement, achieving a single-seed rate of over 95%. Based on a study of garlic morphology, Guo et al.^[15] designed a new type of size-adjustable garlic seed-metering device that accomplished the single-seed of different garlic varieties. Li et al.^[16] designed a new type of hole-wheel garlic seed-metering device, clarified the mechanism behind the hole-wheel structure to improve the seed loading performance of a seed-metering device, and optimized the parameters based on discrete element simulations. Zhang et al.^[17] designed a precision spoon clamp-type garlic seed-metering device according to Asian garlic seeding requirements, achieving the upright seeding of garlic. Zhang et al.^[18] developed a disturbance air-suction garlic seed-metering device, designed an auxiliary seed scrambler tooth to improve the seed loading rate, and examined the effects of different arc lengths for the seed scrambler tooth and suction hole sizes on the performance of the seed-metering device. Although these seed-metering devices achieved single-seed picking, they tended to cause seed injury and leakage and required complicated mechanical structures.

In contrast, finger clip seed-metering devices are a type of mechanical seed displacer that rely on flexible finger clamps to discharge seeds. They can improve sowing accuracy and prevent serious seed injury and poor seed discharge; accordingly, they have been applied to the sowing of maize, potatoes, and other crops. For example, Wang et al.^[19] improved the design of a precision pickup finger seed-metering device that was adaptable to large flat horse-toothed seeds. In addition, Geng et al.^[20] designed a telescopic finger clip-type maize-metering device with a simple structure and a favorable seed discharge effect. Also, Zhang et al.^[21] designed a precision swing clamp-type maize seed-metering device with parameter optimization to address the significant differences in the sizes of the three axes of the maize seed, which easily causes leakage and repeated seed-collection process. Also, Wang et al.^[22] designed a precision pickup finger potato seed-metering device, which achieved single-seed clamping by controlling the opening and closing of the clamping plate and the constraints of the clamping plate on the potato seed during the clearing process. Wang et al.^[23] designed a finger clip plate garlic seed-metering device to address the high empty rate and low single-seed qualification rate in mechanized garlic sowing. Despite these advances, the finger clip plate garlic seed-metering device currently available in the market has an unstable clamping capacity, and the mobility of the seed population in the seed box is low, which results in unsatisfactory operational quality^[23].

To address these issues based on the requirements for sowing single garlic seeds, this study designed and evaluated a precision symmetric finger-clamping garlic seed-metering device; improved the structure and parameter design of the critical components; analyzed the seed loading, clamping, and transfer processes; determined the optimal operational and structural parameters of the seed-metering device based on coupling simulations conducted using EDEM-RecurDyn; and verified the working performance of the seed-metering device via bench tests.

2 Materials and methods

2.1 Structure and operational principle of the seed-metering device

2.1.1 General structure

As shown in Fig. 1, the precision symmetric finger-clamping garlic seed-metering device was composed of a seed tray, pickup fingers, seed-collection spoons, control board that opened and closed the clip, pickup finger fixing boxes, seed-

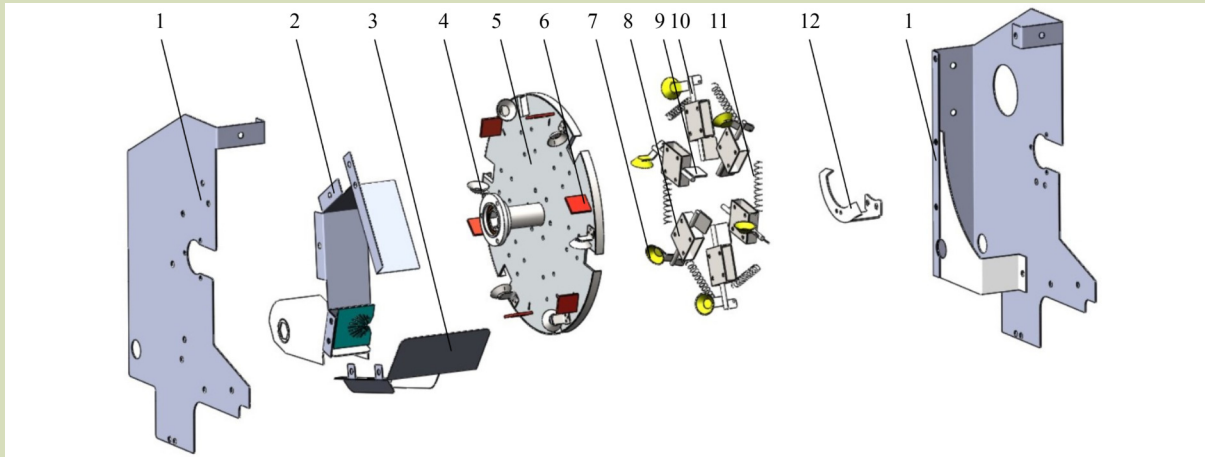

Fig. 1 Seed-metering device: 1, side plates; 2, intermediate partition; 3, falling seed guide plate; 4, seed-collection spoons; 5, seed tray; 6, seed-distribution plates; 7, pickup finger; 8, pickup finger fixing boxes; 9, finger trail clip; 10, finger pole; 11, fine-adjustment springs; and 12, control board that opened and closed the clip.

distribution plates, fine-adjustment springs, falling seed guide plate, intermediate partition, and left- and right-side plates.

2.1.2 Operational principle

As shown in Fig. 2, the seed-metering device operated in four stages: loading, clamping, transfer, and delivery. The finger clip was opened and closed through the coordinated action of the fine-adjustment spring and control board. During the operation, garlic seeds entered the seed-collection spoon in the loading area owing to the force of gravity, inter-seed forces,

and the contact forces between the seeds and seed-collection spoon. The seeds were then moved to the clamping area with the seed-collection spoon. There, the finger clip closed the seed-collection spoon, and unstable seeds fell back into the seed loading area. Single-seed was stably clamped, and then was placed in the seed transfer area. When entering the seed delivery area, the finger clip, and seed-collection spoon were in the most open state, and the seed-delivery process was executed using gravity and centrifugal forces to achieve precise seeding.

2.2 Design of key components

The original structure was designed by our research group^[23]. However, during bench tests, the plate clip sometimes failed to hold seeds and poor seed mobility resulted in a low seeding performance. Therefore, the finger clip and its accessories were redesigned, and a seed-distribution device was added.

2.2.1 Redesigned pickup finger

The pickup finger is a critical component that supplies a clamping force for the seeds in the seed-collection spoon. Its size and structure significantly affect the clamping performance of the seed-metering device. The pickup finger consisted of a lug, clip, pole and trail clip, which were fixed to the seed tray through the pickup finger fixing box. The finger trail clip was in contact with the control board, which worked in conjunction with the fine-adjustment spring to control the opening and closing of the finger clip. To improve the holding performance of the pickup finger, the finger clip was redesigned using the same seed-collection spoon, as shown in Fig. 3.

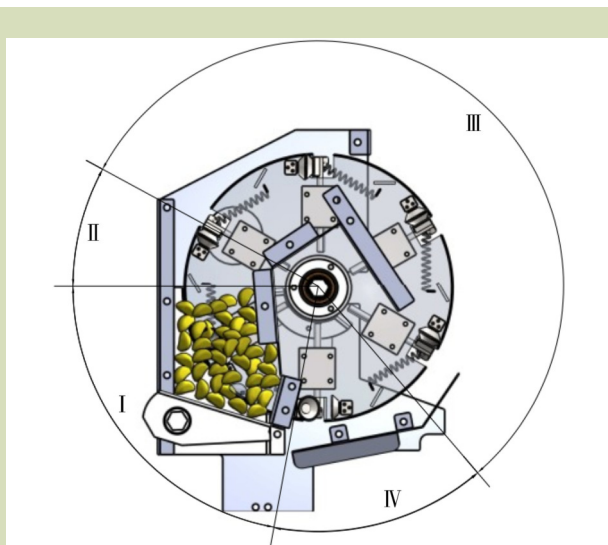

Fig. 2 Seed-metering device: I, loading area; II, clamping area, III, transfer area; and IV, delivery area.

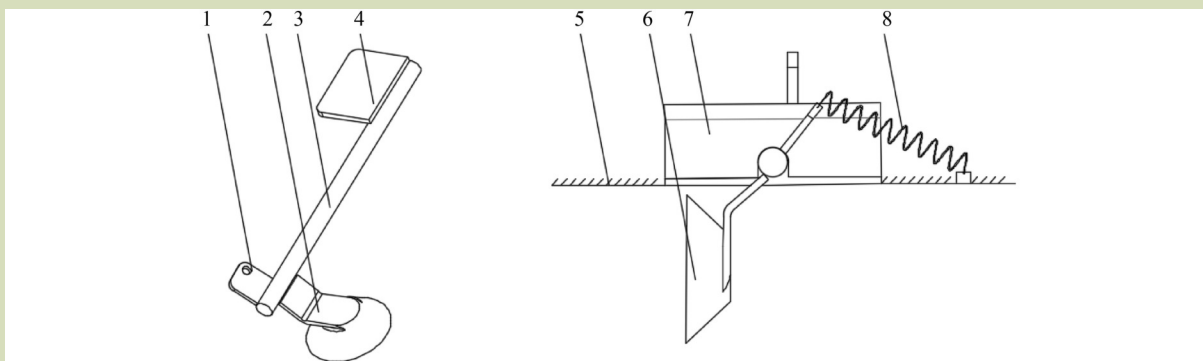

Fig. 3 Pickup finger structure: 1, finger lug; 2, finger clip; 3, finger pole; 4, finger trail clip; 5, seed tray; 6, collection spoon; 7, pickup finger fixing box; and 8, fine-adjustment spring.

As shown in Fig. 3, the seed-collection spoon is an essential component for capturing seeds. When used together with the spoon, a pair of symmetric spoon clips were formed. Based on the results of previous study by our research group^[23], the depth h of the spoon assigned a value of 8 mm, and the optimal opening diameter R was 26 mm. The taper (T) of a spoon was defined as:

$$T = \frac{R-r}{h} \tag{1}$$

where, r is the bottom diameter of the spoon, as shown in Fig. 4.

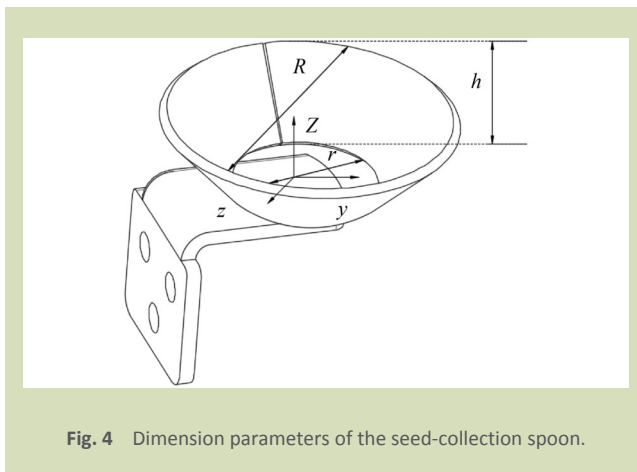

Fig. 4 Dimension parameters of the seed-collection spoon.

To investigate the influence of the spoon taper on the seed-collection performance of the seed-metering device, the value of r was chosen to be between 10 and 15 mm, and the corresponding value for T was between 1.2 and 2. The optimal spoon taper was subsequently determined via simulations.

fixed on the seed tray, as shown in Fig. 5. Three installation angles of 30°, 60° and 90° were used.

2.2.2 Seed-distribution device

The seed-distribution device was used to increase the efficiency of the seed-metering device, which was designed in the form of a plate located between the seed-collection spoons and was

The optimal installation angle, speed of the seed tray and number of spoons were determined through the simulations. The seed tray had a diameter of 320 mm and thickness of 3 mm, as described previously^[23].

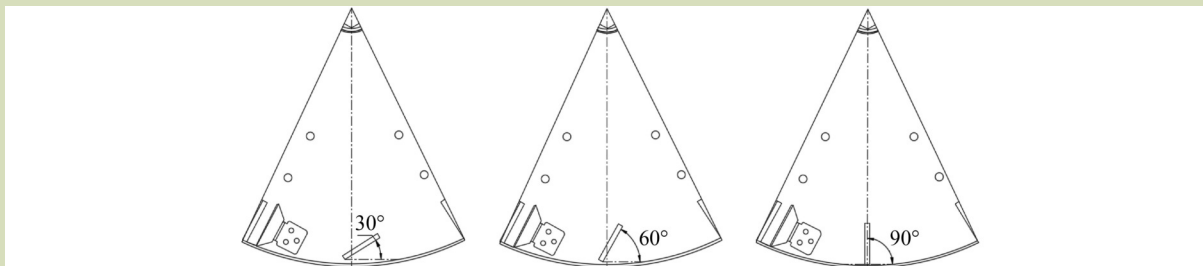

Fig. 5 Installation angles of the seed-distribution plate.

2.2.3 Control board

The control board is the core component used to control the opening and closing of the finger clip. The precise control of the opening and closing of the finger clip ensures that the seed-metering device can adequately perform seed loading and clamping. The stroke of the finger clip includes four stages: gradual opening, complete opening, gradual closing, and complete closing.

The control board divides the circumferential angle of the seed tray into four zones based on the opening and closing strokes of the finger clip. These zones include gradual and complete opening, and gradual and complete closing, as shown in Fig. 6.

To ensure that the finger clip opens and closes smoothly during seed clamping and delivery, and to reduce the impact of the seeds on the seed-collection spoon, the part of the control board located in the finger clip gradual closing and opening zones was designed as a inclined surface, as shown in Fig. 7.

Based on the positions of the seed loading and delivery areas, the finger clip gradual opening angle was set to 10° , the finger clip complete opening angle was set to 120° and the finger clip gradual closing angle was set to $10^\circ\text{--}30^\circ$. The optimal finger clip gradual closing angle was subsequently determined via a simulation.

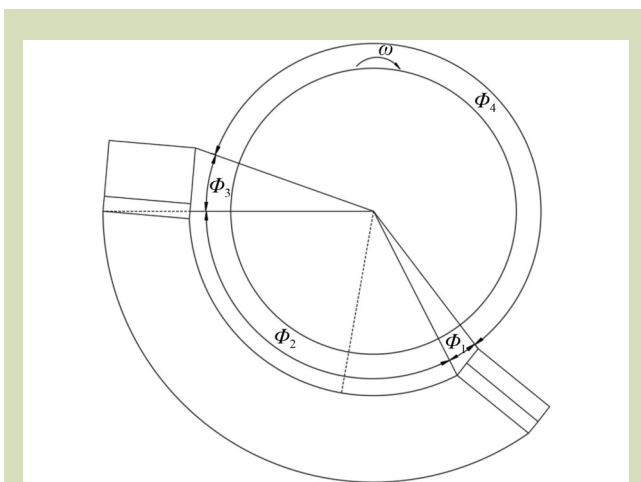

Fig. 6 Control board partitions. The finger clip gradual opening angle is denoted by Φ_1 , the finger clip complete opening angle is denoted by Φ_2 , the finger clip gradual closing angle is denoted by Φ_3 and the finger clip complete closing angle is denoted by Φ_4 .

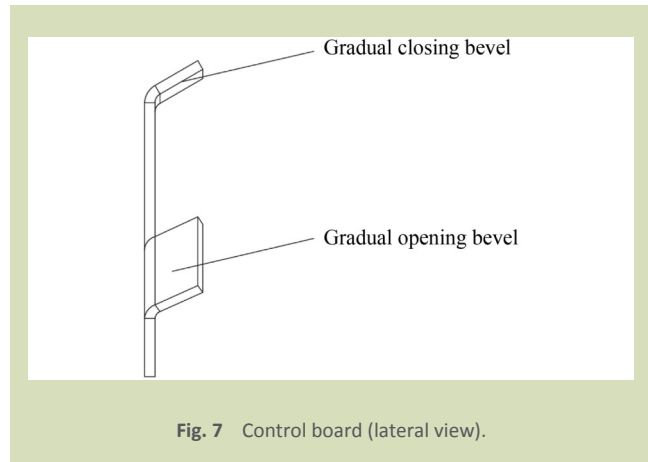

Fig. 7 Control board (lateral view).

2.3 Theoretical analysis of the seed loading process

2.3.1 Force analysis

The seed loading process of a seed-metering device is complex and has a significant impact on the seeding accuracy of the seed-metering device. In the seed loading area, seeds are affected by the force of gravity and contact forces from the seed population and the spoon. Depending on the relative position of the target garlic seed, the seed loading process can be divided into two cases (Fig. 8): the spoon with and without a seed. The force analysis of the target garlic seed during the seed loading process yielded the equation

$$\begin{cases} mg + \sum_{i=1}^n F_i + F_N = ma \\ \sum_{i=1}^n M_o(F_i) + M_o(mg) + M_o(F_N) = m\alpha \end{cases} \quad (2)$$

where, F_i is the force of the surrounding garlic (N), m is the mass of the target garlic seed (kg), F_N is the supporting force of the spoon (N), a is the target seed acceleration ($\text{m}\cdot\text{s}^{-2}$), g is the acceleration due to gravity ($9.8 \text{ m}\cdot\text{s}^{-2}$), α is the target seed angular acceleration ($\text{rad}\cdot\text{s}^{-2}$) and M_o is the moment of the force ($\text{N}\cdot\text{m}$).

Case 1: spoon without garlic seed. The spoon entered the seed loading area, and the target garlic seed tended to rotate in the direction of the spoon owing to gravity and the contact forces of the surrounding seeds and the spoon. This allowed the seeds that had not yet entered the spoon to fall smoothly into the spoon.

Case 2: spoon with garlic seed. The garlic seed was subjected to various forces, including the contact forces of the surrounding seeds and the spoon. At this time, the seeds around the spoon were in a competitive state and tended to stabilize.

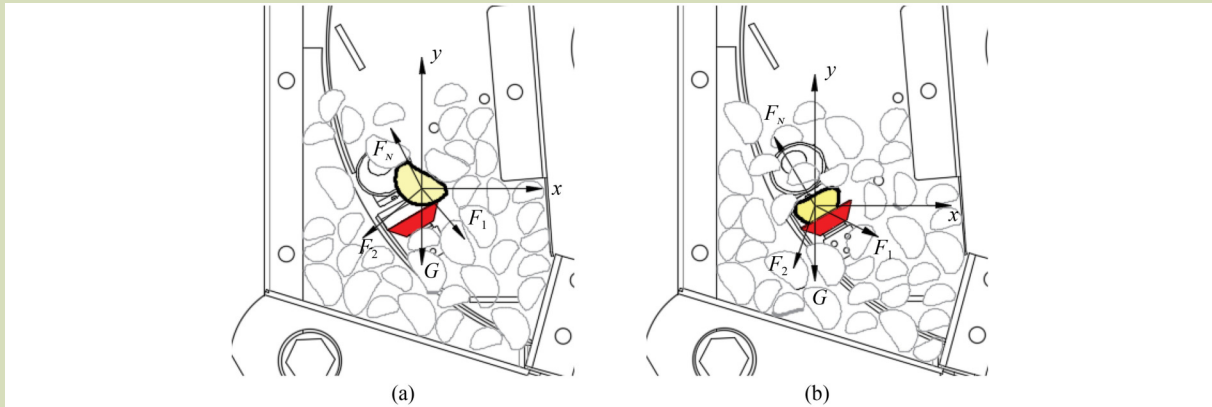

Fig. 8 Force analysis of target seed for different conditions during seed-collection: (a) without garlic seed in the spoon; (b) with garlic seed in the spoon.

Based on the analysis described above, when the spoon entered the seed loading area, the target garlic seed in the spoon was stable. After the seed has left the seed population, detaching it from the spoon is difficult.

2.3.2 Analysis of clamping dynamics

The processes of clamping and transfer the seeds are critical stages in the operation of a seed-metering device. These stages significantly affect seed delivery, and stable clamping of the seed pickup finger is important for improving the operational performance of the metering device. During these two stages, the clamping force of the pickup finger on the garlic seed was provided by the fine-adjustment spring.

Figure 9 shows the force analysis of the pickup finger during the seed clamping and transfer processes. The pickup finger underwent vertical and horizontal support forces from the pickup finger fixing box (denoted as N_1, N_2), the reaction force from the garlic seed (denoted as F'_n), the frictional force from the garlic seed (denoted as f'), and the tension force from the fine adjustment spring (denoted as P). To ensure that the garlic seed and pickup finger moved smoothly during the seed clamping and transfer processes, it was necessary to maintain the balance of the forces at the center of rotation of the pickup finger, which can be expressed as:

$$\begin{cases} \sum M = 0 \\ f'r + Pl = F'_n l_n \\ f = \mu F_n \end{cases} \quad (3)$$

where, M is the moment of the finger pole relative to the center of rotation (N·m), f is the friction force between the spoon and garlic seed (N; $f' = f$), F_n is the contact force exerted on the

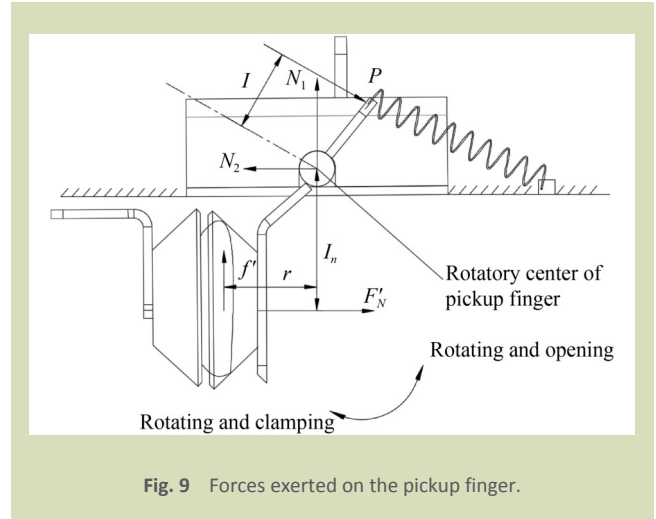

Fig. 9 Forces exerted on the pickup finger.

garlic seed by the spoon (N ; $F'_n = F_n$), μ is the friction coefficient between the spoon and garlic seed, r is the distance between the spoon and the center of rotation of the pickup finger (mm), l is the arm of the spring force (mm) and l_n is the arm of the contact force of the spoon (mm).

Reorganizing Eq. (3) yields:

$$F_n = \frac{Pl}{l_n - \mu r} \quad (4)$$

which indicates that when the pickup finger structural parameters and the size of the garlic seed are fixed, the clamping force of the spoon increases as the spring force increases.

The forces exerted on the garlic seed are shown in Fig. 10.

The garlic seed was affected by several forces, including the

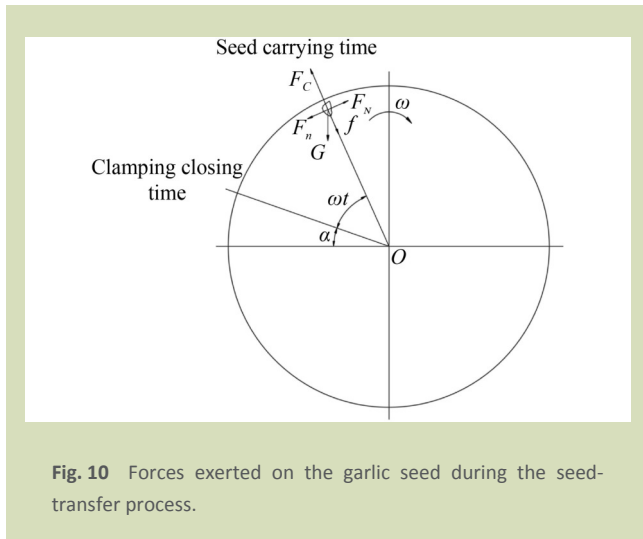

Fig. 10 Forces exerted on the garlic seed during the seed-transfer process.

contact force exerted by the spoon, the clamping force exerted by the pickup finger, friction forces and gravity. To ensure the stable clamping of the garlic seed, the forces in both the tangential and normal directions of the seed trajectory must be balanced, which requires satisfying

$$\begin{cases} F_n = F_N \\ G \sin(\alpha + \omega t) + f = F_c \end{cases} \quad (5)$$

where, F_n and F_N are the clamping forces exerted by the spoon to the right and left, respectively, G is the gravitational force on the garlic seed, F_c is the centrifugal force on the garlic seed, α is the clamping angle, ω is the rotational speed of the seed tray and t is the time over which the seed is clamped and carried. Substituting $f = \mu F_n$ and $F_c = m\omega^2 R$ into Eq. (5) yields:

$$F_n = \frac{m\omega^2 R - G \sin(\alpha + \omega t)}{\mu} \quad (6)$$

where, R is the radius of the seed trajectory. Taking the second-order derivative of Eq. (6) results in:

$$\frac{d^2 F_n}{d\omega^2} = \frac{m}{\mu} (2R + g t^2 \sin(\alpha + \omega t)). \quad (7)$$

The friction coefficient between the garlic seed and the resin material of the spoon was 0.466^[14]. When the rotation angle $(\alpha + \omega t)$ was between $(0, \frac{23\pi}{18})$, $\sin(\alpha + \omega t)$ was always greater than zero, and the clamping force varied as a concave function (i.e., it decreased and then increased as the speed of the seed tray increased). When the rotation angle $(\alpha + \omega t)$ was between $(\frac{23\pi}{18}, \frac{11\pi}{9})$, $\sin(\alpha + \omega t)$ was always less than zero, and the clamping force varied as a convex function (i.e., it increased and then decreased as the speed of the seed tray increased).

In summary, the main factors affecting the clamping performance of the pickup finger were the spring force and

speed of the seed tray. The overall operational process of the seed-metering device and the pretest suggested that the spring force should be 0.8 N. The speed of the seed tray was then optimized, as described below.

2.4 Simulations based on DEM-MBD coupling

2.4.1 Simulation modeling

Simplified RecurDyn and EDEM models of the seed-metering device are shown in Fig. 11 and Fig. 12, respectively. During the operation of the seed-metering device, the shaft of the metering device rotated the seed tray. The control board and fine-adjustment spring worked together to control the opening and closing of the pickup finger.

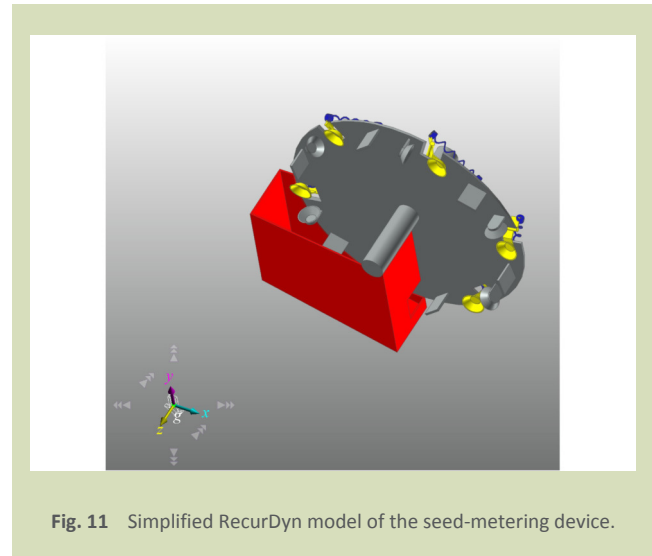

Fig. 11 Simplified RecurDyn model of the seed-metering device.

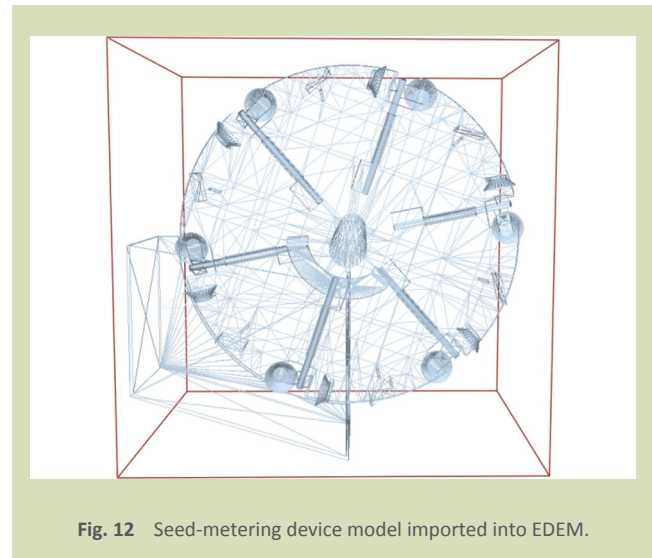

Fig. 12 Seed-metering device model imported into EDEM.

Constraints were added to RecurDyn as follows: the seed box and control board were fixed to the ground; a rotating vice was added between the seed tray and ground, and the corresponding rotational speed was adjusted according to the speed of the seed tray; a rotating vice was added between each pickup finger and the seed tray; a solid-to-solid contact was added between each seed pickup finger and the control board, as well as between each seed pickup finger and the seed tray; and a spring module was added between each seed pickup finger and each fine-adjustment spring positioning block.

The simulations employed a white garlic particle model widely used in Xuzhou, Jiangsu Province, China. A garlic seed close to the average three-axis size was selected and its three-dimensional model was obtained using reverse engineering technology. The model was imported into EDEM and a multi-spherical aggregated particle model of the garlic seed was obtained through the particle rapid-loading function. The Hertz-Mindlin no-slip model was used as the contact model in the simulation because there was no particle-particle and particle-discharger adhesion. The garlic seed particles were generated using a normal distribution.

The material selected for the seed box, seed tray, and control board in this model was 45# steel whereas resin was selected as the seed-collection spoon, seed-distribution plate and pickup finger material. These parameters are listed in Table 1 and Table 2^[14].

In EDEM, the Rayleigh time step was set to 20%, and the grid size of the computational domain was set to 2.5R. Each set of experiments was repeated three times, with 100 seed collection

spoons used each time to count the number of seeds extracted. A grid-bin group square was set up to monitor the seed extraction of the seed expeller (as shown in Fig. 13). The simulation process exhibited three loading states, as shown in Fig. 14.

2.4.2 Single-factor simulations

Single-factor simulation tests were conducted using EDEM-RecurDyn coupling to determine the structure and working parameters of the seed-metering device. The tests focused on the operational performance of the seed-metering device and used the single-seed (1 seed per spoon), empty (0 seed per spoon), and multiple-seed (≥ 2 seeds per spoon) rates as the experimental indices. The effects of various factors on the operational performance of the metering device were analyzed.

2.4.3 Quadratic regression orthogonal rotation combination simulation test

To examine the impact of the interactions between the spoon taper, finger clip gradual closing angle and seed tray rotation speed on the operational performance of the seed-metering device, and to determine the optimal combination of parameters, the second orthogonal rotary combination simulation test was performed using the evaluation indices of the single-seed (Y_1), empty (Y_2), and multiple-seed (Y_3) rates. The experimental scheme is summarized in Table 3.

2.5 Bench test materials and equipment

White garlic from Xuzhou, Jiangsu Province, China was used as the test material. A seed-metering device prototype was

Table 1 Material parameters

Material	Density ($\text{kg}\cdot\text{m}^{-3}$)	Poisson's ratio	Elastic modulus (MPa)
Garlic seeds	1080	0.23	23.8
Steel (45#)	7800	0.25	68,935
Resin	1140	0.394	2000

Table 2 Simulation parameters

Contact	Collision recovery coefficient	Static friction factor	Dynamic friction factor
Seed-seed	0.492	0.385	0.102
Seed-steel	0.427	0.473	0.234
Seed-resin	0.432	0.466	0.214

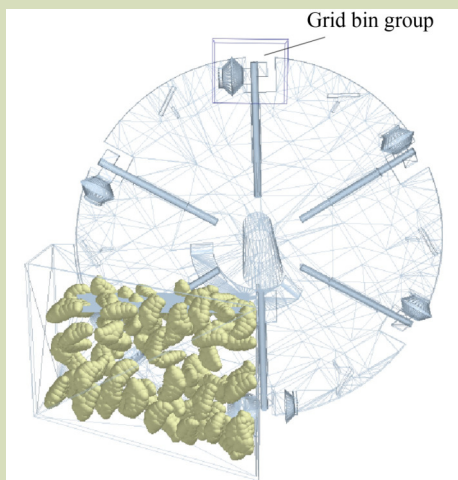

Fig. 13 Monitoring area model.

manufactured, and a seed-metering device operational performance test rack was built. The test was conducted at the Mechanical Performance Laboratory of the College of Engineering, Nanjing Agricultural University, as shown in

Fig. 15. The materials of the seed-metering device components were the same as those used in the simulation.

3 Results and discussion

3.1 Single-factor simulation analysis

3.1.1 Installation angle of the seed-distribution plate

The test results are given in Table 4. Figure 16 shows the average speed of the seed population for different installation angles of the seed-distribution plate.

Table 4 and Fig. 16 show that as the installation angle increased, the effect of the seed-distribution plate decreased, which reduced the seed population velocity and increased the likelihood that the seeds would accumulate. This also decreased the probability of the seeds filling the spoon, thereby reducing the operational performance of the seed-metering device. Based on the results of the simulations, an installation angle of 30° for the seed-distribution plate is recommended.

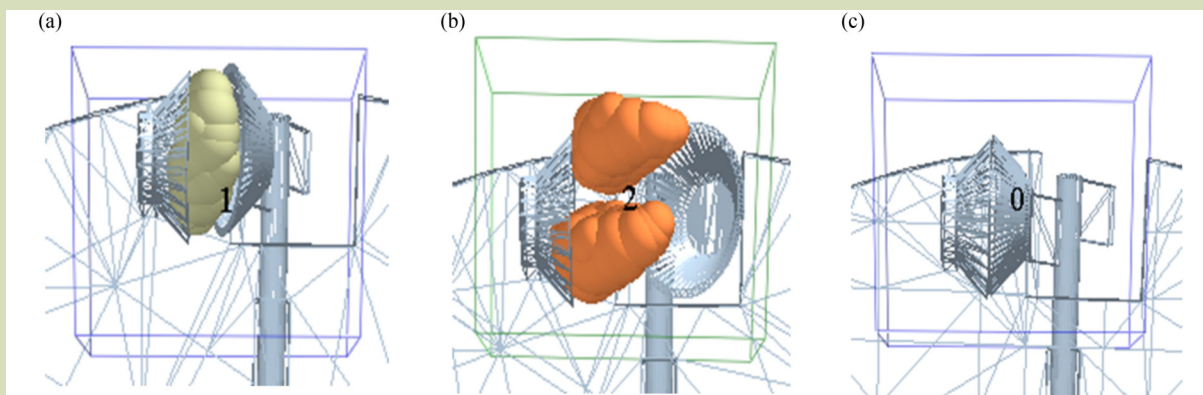

Fig. 14 Three loading states exhibited during the simulation process: (a) single-seed; (b) multiple-seed; and (c) no seed (empty).

Table 3 Experimental scheme

Code	Factor		
	Spoon taper X_1	Finger clip gradual closing angle X_2 (°)	Rotation speed X_3 (r·min ⁻¹)
-1.682	1.40	15	25
-1	1.48	17	27
0	1.60	20	30
1	1.72	23	33
1.682	1.80	25	35



Fig. 15 Bench validation test: 1, conveyor belt; 2, motor; 3, motor governor; 4, seed-metering device; 5, mounting rack; 6, seed loading chamber; 7, seed-collection spoon; 8, pickup finger; and 9, seed-distribution plate.

Table 4 Simulation results for different installation angles of the seed-distribution plate

Seed-distribution plate installation angle (°)	Single-seed rate (%)	Mean (%)	Empty rate (%)	Mean (%)	Multiple-seed rate (%)	Mean (%)
30	93/94/93	93.3	1/4/2	2.3	6/2/5	4.3
60	93/91/91	91.7	5/2/5	4.0	2/7/4	4.3
90	90/90/88	89.3	7/6/4	5.7	3/4/8	5.0

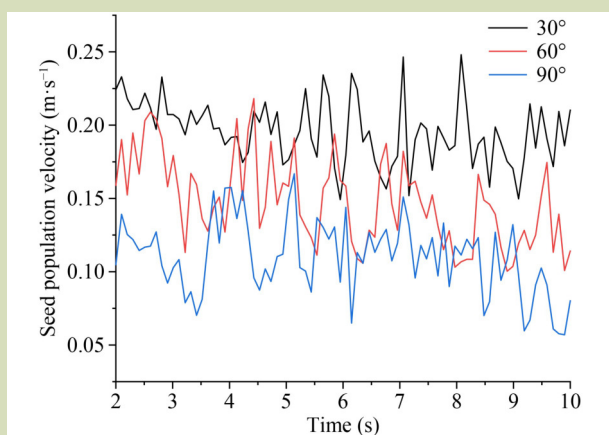

Fig. 16 Seed population velocity curves for different installation angles of the seed-distribution plate.

3.1.2 Number of spoons

The simulation results for different numbers of spoons (5 to 8) are given in Table 5. As the number of spoons increased, the single-seed rate of the seed-metering device increased and then decreased, whereas the empty rate decreased and then increased. With five spoons, the large spacing between the

spoons resulted in low flow stability and a low single-seed rate. With eight spoons, the spacing was too small to fill the spoons promptly, thereby increasing the empty rate. Therefore, the optimal number of spoons was six.

3.1.3 Taper of the spoon

The results for the single-seed, empty and multiple-seed rates of the seed-metering device for spoon tapers of 1.2, 1.4, 1.6, 1.8, and 2 are shown in Fig. 17. As the tapering of the spoon increased, the inter-seed forces increased, leading to an increased probability of seeds entering the spoon. Consequently, the empty rate of the seed-metering device decreased, and the single-seed rate initially increased. However, as the taper of the spoon continued to increase, the multiple-seed rate increased, resulting in a decrease in the single-seed rate. To account for the interaction between the factors in the subsequent experiments, the taper of the spoon was limited to a range of 1.4–1.8.

3.1.4 Finger clip gradual closing angle

The results for single-seed, empty and multiple-seed rates for finger clip gradual closing angles of 10°, 15°, 20°, 25°, and 30° are shown in Fig. 18. As the multiple-seed rate of the seed-

Table 5 Simulation results for different numbers of spoons

Number of spoons	Single-seed rate (%)	Mean (%)	Empty rate (%)	Mean (%)	Multiple-seed rate (%)	Mean (%)
5	85/88/90	87.7	6/6/3	5.0	9/6/7	7.3
6	94/93/94	93.7	3/2/2	2.3	3/5/4	4.0
7	91/90/93	91.3	4/4/3	3.7	5/6/4	5.0
8	91/89/87	89.0	7/7/6	6.7	2/4/7	4.3

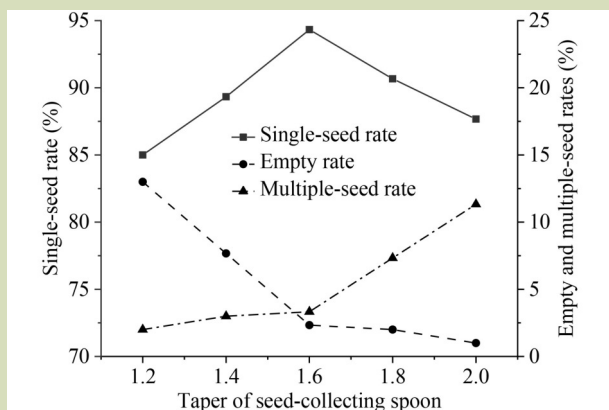

Fig. 17 Relationship between evaluation indicators and different spoon tapers.

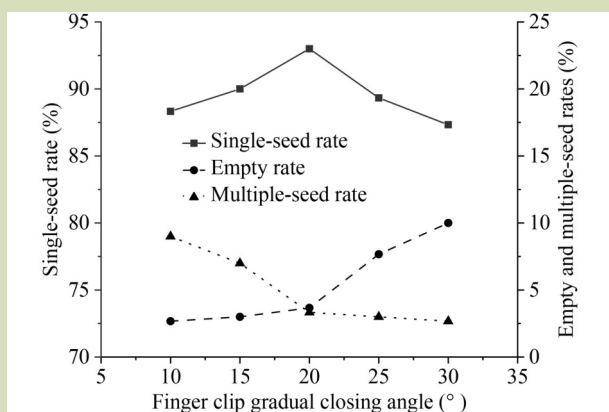

Fig. 18 Relationship between evaluation indicators and different finger clip gradual closing angles.

metering device decreased as the finger clip gradual closing angle increased whereas the single-seed rate initially increased. However, as the finger clip gradual closing angle continued to increase, the empty rate increased, leading to a decreased single-seed rate. This indicated that a slight finger clip gradual closing angle led to an excess of seeds in the seed-collection

spoon that could not exit in time, resulting in a higher multiple-seed rate. As the finger clip gradual closing angle increased, the probability of seeds leaving the seed-collection spoon also increased, leading to a higher empty rate. To consider the interaction between various factors in the subsequent tests, the finger clip gradual closing angle was limited to a range of 15°–25°.

3.1.5 Rotation speed of the seed tray

The results for single-seed, empty, and multiple-seed rates of the seed-metering device for rotation speeds of 20, 25, 30, 35, and 40 r·min⁻¹ are shown in Fig. 19. As the rotation speed of the seed tray increased, the multiple-seed rate decreased whereas the single-seed rate initially increased. However, as the seed tray rotation speed continued to increase, the empty rate increased, ultimately resulting in a decreased single-seed rate. This indicates that as the rotation speed of the seed tray increased, garlic seed activity in the seed loading area also increased. Consequently, it was difficult to form a pile of seeds between the spoons. To consider the interaction between various factors in the subsequent tests, the seed tray rotation speed was limited to a range of 25–35 r·min⁻¹.

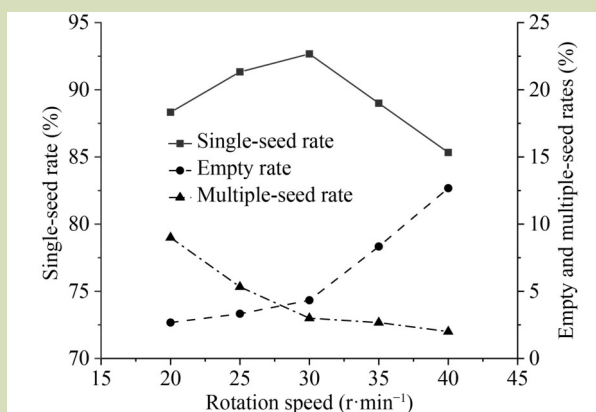

Fig. 19 Relationship between evaluation indicators and different rotation speeds of the seed tray.

3.2 Quadratic regression orthogonal rotation combination simulation test

3.2.1 Statistical analysis

The test results are given in Table 6. The experimental data were analyzed using ANOVA in the Design-Expert software, and these results are shown in Table 7. The ANOVA results indicated that the quadratic regression models for the single-seed (Y_1), empty rate (Y_2), and multiple-seed rate (Y_3) rate were highly significant ($p < 0.01$). The out-of-fit term was not significant ($p > 0.05$). The regression equations for Y_1 , Y_2 , and Y_3 , which were obtained by eliminating non-significant factors in the model, were:

$$Y_1 = 93.54 - 1.4X_1 + 1.19X_2 + 1.69X_3 + 0.92X_1X_2 + 1.5X_1X_3 - 1.43X_1^2 - 1.37X_2^2 - 1.37X_3^2 \quad (8)$$

$$Y_2 = 2.44 - 1.13X_1 - 2.31X_2 + 1.02X_3 - 0.88X_1X_3 + 0.67X_1^2 + 0.84X_2^2 \quad (9)$$

$$Y_3 = 4.02 + 2.53X_1 + 1.13X_2 - 2.71X_3 - 0.63X_1X_3 + 0.77X_1^2 + 0.53X_2^2 + 0.88X_3^2 \quad (10)$$

According to Table 7 and the coefficient test of the regression equation, the factors affecting the single-seed rate were, in order of importance, the rotation speed, taper of the spoon, and the finger clip gradual closing angle. There were interactions between the taper of the spoon and the finger clip gradual closing angle, as well as the interaction between the taper of the spoon and the rotation speed, so these must be taken into consideration.

The factors affecting the empty rate were, in order of importance, the finger clip gradual closing angle, taper of the

Table 6 Experimental design and results

No.	Factor			Test indicator		
	X_1	X_2	X_3	Y_1 (%)	Y_2 (%)	Y_3 (%)
1	-1	-1	-1	89.7	6.0	4.3
2	1	-1	-1	83.3	5.7	11.0
3	-1	1	-1	91.3	1.0	7.7
4	1	1	-1	86.0	1.3	12.7
5	-1	-1	1	91.3	8.0	0.7
6	1	-1	1	88.3	7.0	4.7
7	-1	1	1	89.3	6.7	4.0
8	1	1	1	92.7	0.7	6.7
9	-1.682	0	0	92.3	6.7	1.0
10	1.682	0	0	87.7	1.7	10.7
11	0	-1.682	0	87.3	9.0	3.7
12	0	1.682	0	93.0	0.3	6.7
13	0	0	-1.682	86.7	2.0	11.3
14	0	0	1.682	93.7	5.3	1.0
15	0	0	0	93.3	3.0	3.7
16	0	0	0	94.3	2.7	3.0
17	0	0	0	92.7	2.7	4.7
18	0	0	0	92.0	3.7	4.3
19	0	0	0	94.0	1.7	4.3
20	0	0	0	93.0	3.0	4.0
21	0	0	0	94.7	2.3	3.0
22	0	0	0	94.3	0.7	5.0
23	0	0	0	93.3	2.3	4.3

Table 7 Variance analysis

Source	Single-seed rate (Y_1)				Empty rate (Y_2)				Multiple-seed rate (Y_3)			
	SS	df	F	p	SS	df	F	p	SS	df	F	p
Model	201	9	17.9	< 0.0001 ^b	135	9	16.1	< 0.0001 ^b	236	9	42.1	< 0.0001 ^b
X_1	26.9	1	21.5	0.0005 ^b	17.4	1	18.6	0.0008 ^b	87.7	1	141	< 0.0001 ^b
X_2	19.2	1	15.4	0.0018 ^b	73.0	1	78.1	< 0.0001 ^b	17.3	1	27.9	0.0001 ^b
X_3	39.1	1	31.2	< 0.0001 ^b	14.2	1	15.2	0.0018 ^b	100	1	161	< 0.0001 ^b
X_1X_2	6.75	1	5.39	0.0371 ^a	2.35	1	2.52	0.1367	1.33	1	1.81	0.2014
X_1X_3	18.0	1	14.4	0.0022 ^b	6.13	1	6.55	0.0238 ^a	3.13	1	5.03	0.043 ^a
X_2X_3	0.495	1	0.395	0.5405	0.353	1	0.377	0.5498	0.013	1	0.021	0.8881
X_1^2	32.6	1	26.0	0.0002 ^b	7.05	1	7.53	0.0167 ^a	9.36	1	15.1	0.0019 ^b
X_2^2	30.0	1	23.9	0.0003 ^b	11.2	1	12.0	0.0042 ^b	4.50	1	7.24	0.0185 ^a
X_3^2	29.9	1	23.9	0.0003 ^b	3.77	1	4.03	0.0658	12.4	1	20.0	0.0006 ^b
Residual	16.3	13			12.2	13			8.08	13		
Lack of fit	10.1	5	2.58	0.1126	6.17	5	1.65	0.2528	4.20	5	1.74	0.2322
Error	6.24	8			6	8			3.87	8		
Sum	218	22			147	22			243	22		

Note: ^a Significant difference ($0.01 < p < 0.05$); ^b Highly significant difference ($p < 0.01$). SS, sum of square; df, degree of freedom.

spoon, and rotation speed. There was an interaction between the taper of the spoon and the rotation speed, so this must be taken into consideration.

Finally, the factors affecting the multiple-seed rates were, in order of importance, the rotation speed, taper of the spoon, and the finger clip gradual closing angle. There was an interaction between the taper of the spoon and the rotation speed, so this must be taken into consideration.

3.2.2 Effect on single-seed rate

Using Design-Expert 11 software, the effects of the interactions between taper of spoons and finger clip gradual closing angle or rotation speed on the single-seed rate (Y_1) were obtained, as evident in the response surface (Fig. 20).

Figure 20(a) shows that at a rotation speed of $30 \text{ r}\cdot\text{min}^{-1}$, finger clip gradual closing angle remained constant. As the taper of the spoon increased, the single-seed rate first increased gradually and then decreased. When the taper of the spoon was

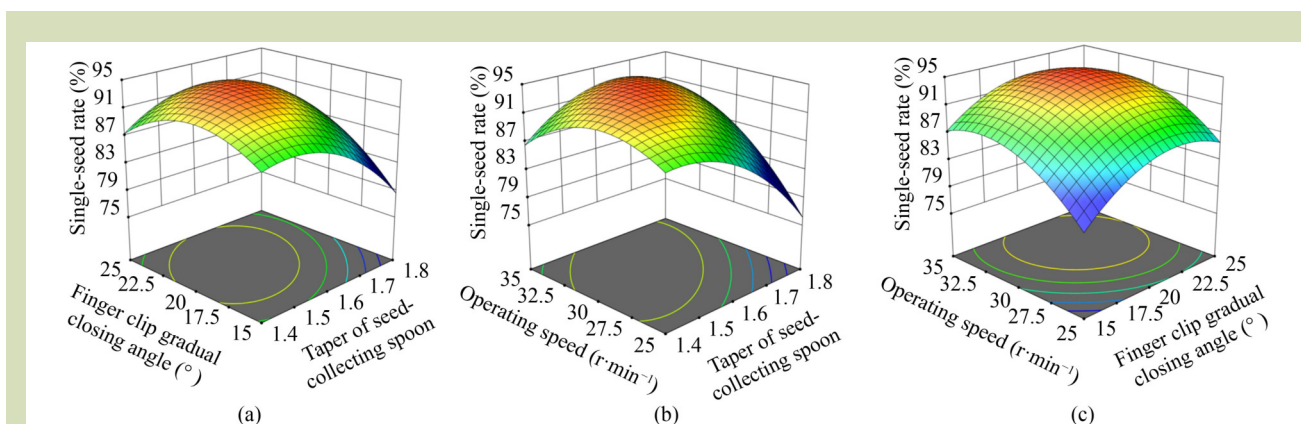

Fig. 20 Effects of interacting factors on the single-seed rate: (a) finger clip closing angle vs. taper of seed-collection spoon; (b) operation speed vs. taper of seed-collection spoon; and (c) operating speed vs. finger clip gradual closing angle.

constant, an increase in the finger clip gradual closing angle resulted in an initial increase and then a subsequent decrease in the single-seed rate. When the taper of the spoon was 1.4–1.6 and the finger clip gradual closing angle was 17.5°–22.5°, the single-seed rate was relatively large.

Figure 20(b) shows that for a finger clip gradual closing angle of 20°, an increase in the taper of the spoon resulted in an initial gradual increase and a subsequent decline in the single-seed rate. When the taper of the spoon was constant, an increase in the rotation speed resulted in an initial increase, followed by a decrease in the single-seed rate. When the taper of the spoon was 1.4–1.6 and the rotation speed was 27.5–32.5 r·min⁻¹, the single-seed rate was relatively large.

Figure 20(c) shows that for a spoon taper of 1.6, an increase in the finger clip gradual closing angle resulted in an initial gradual increase, followed by a decline in the single-seed rate. When the finger clip gradual closing angle was constant, an increase in the rotation speed resulted in an initial increase, followed by a decrease in the single-seed rate. When the finger clip gradual closing angle was 20°–25° and the rotation speed was 30–35 r·min⁻¹, the single-seed rate was relatively high.

3.2.3 Parameter optimization

An optimization model was established to obtain the optimal combination of parameters for seed discharge. The model was based on the boundary conditions, with the highest single-seed rate, and the lowest empty and multiple-seed rates as the optimization objectives:

$$\left\{ \begin{array}{l} \max Y_1(X_1, X_2, X_3) \\ \max Y_2(X_1, X_2, X_3) \\ \max Y_3(X_1, X_2, X_3) \\ -1.682 \leq X_1 \leq 1.682 \\ -1.682 \leq X_2 \leq 1.682 \\ -1.682 \leq X_3 \leq 1.682 \end{array} \right. \quad (11)$$

The performance of the seed-metering device was optimized by optimizing its parameters. The taper of the seed-collection spoon was set to 1.6, the finger clip gradual closing angle was set to 21.4°, and the rotation speed was set to 31.5 r·min⁻¹. These settings resulted in a single-seed rate of 94.2%, an empty rate of 2.1%, and a multiple-seed rate of 3.7%. These rates are superior to those reported for previous study of our research group^[23]. The advantage of the methods used in this study is that they are capable of performing analyses quickly and do not need to consider all possible combinations to obtain results. The disadvantage is that only the optimal combination of the

existing data can be obtained and not the optimal combination of other intermediate values.

3.3 Bench validation test

A test was conducted to verify the actual operational performance of the seed-metering device. Based on the optimal parameters, the seeding spoon taper was set to 1.6, the finger clip gradual closing angle was set to 21.4°, and the rotation speed was set to 31.5 r·min⁻¹. The tests were repeated three times using these parameters. The average evaluation index was calculated and a single-seed rate of 93.3%, empty rate of 2.7%, and multiple-seed rate of 4% were obtained, satisfying the garlic seeding requirements.

4 Conclusions

This study evaluated the structure and operational principles of a precision symmetric finger-clamping garlic seed-metering device, and improved the key components. Symmetric seed-collection spoon and seed-distribution plate structures were designed, analyses of the forces involved in the seed loading process and of the clamping dynamics were conducted, and the parameters of the seed-metering device were optimized. Some useful results were listed below:

- (1) The optimal installation angle of the seed-distribution plate and optimal number of seed-collection spoons were determined via single-factor simulation tests based on DEM-MBD coupling. Additionally, the effects of different seed-collection spoon tapers, finger clip gradual closing angles, and seed tray rotation speeds on the performance of the metering device were analyzed.
- (2) The optimal combination of parameters was obtained by optimizing the seed-metering parameters when the taper of the seed-collection spoon was 1.6, the finger clip gradual closing angle was 21.4°, and the rotation speed of the seed tray was 31.5 r·min⁻¹.
- (3) The ideal parameter combination was tested and confirmed using bench validation tests. The operational performance results showed that for the optimal combination of parameters, the single-seed rate was 94.2%, the empty rate was 2.1%, and the multiple-seed rate was 3.7%. These results can be used to achieve ideal designs for precision symmetric finger-clamping garlic seed-metering devices.

Acknowledgements

This research was supported by Jiangsu Modern Agricultural Industry Key Technology Innovation Project [CX(19)2007], Jiangsu Middle Late Garlic Industry Cluster Sub Project “Demonstration and Promotion for the Technology of Mechanization Intelligent Operation and Green Production for the Garlic” and Jiangsu Modern Agricultural Equipment and Technology Demonstration and Promotion Project (NJ2021-12, NJ2022-09).

Compliance with ethics guidelines

Qian Zhang, Yongjian Wang, Hua Li, Jifeng Gao, and Yuangeng Ding declare that they have no conflicts of interest or financial conflicts to disclose. This article does not contain any studies with human or animal subjects performed by any of the authors.

REFERENCES

- Farhat Z, Scheving T, Aga D S, Hershberger P A, Freudenheim J L, Hageman Blair R, Mammen M J, Mu L. Antioxidant and antiproliferative activities of several garlic forms. *Nutrients*, 2023, **15**(19): 4099
- Okoro B C, Dokunmu T M, Okafor E, Sokoya I A, Israel E N, Olusegun D O, Bella-Omunagbe M, Ebubechi U M, Ugbogu E A, Iweala E E J. The ethnobotanical, bioactive compounds, pharmacological activities and toxicological evaluation of garlic (*Allium sativum*): a review. *Pharmacological Research - Modern Chinese Medicine*, 2023, **8**: 100273
- Sahidur M R, Islam S, Jahurul M H A. Garlic (*Allium sativum*) as a natural antidote or a protective agent against diseases and toxicities: a critical review. *Food Chemistry Advances*, 2023, **3**: 100353
- Assimiti D. Health benefits of the culinary use of garlic—Case study and lessons from COVID-19 pandemic in Thailand. *Current Developments in Nutrition*, 2022, **6**: 735
- Zhao S, Jia Y, Zhang W, Wang L, Ma Y, Teng K. Oral administration of *Allium sativum* extract protects against infectious bursal disease in chickens. *Frontiers of Agricultural Science and Engineering*, 2015, **2**(4): 318–326
- Li Y, Niu C, Jia S. Analysis of the current research situation on mechanized garlic seeding. *Xinjiang Agricultural Mechanization*, 2021, (2): 29–33 (in Chinese)
- Wei H, Wang X, Chen J, Cui R. Discussion on the present situation and development of mechanized garlic production in China. *Journal of Chinese Agricultural Mechanization*, 2022, **43**(4): 175–182 (in Chinese)
- Geng A, Zhang C, Song Z, Yang J, Li R, Hou J, Liu S. Kinematic analysis and parameter optimized experiment of garlic box putting process. *Transactions of the Chinese Society of Agricultural Engineering*, 2016, **32**(5): 29–35 (in Chinese)
- Cui R, Huang J, Zhang Z, Wang X, Jian S. Research status of garlic mechanized sowing technology. *Agricultural Equipment & Vehicle Engineering*, 2018, **56**(6): 54–56 (in Chinese)
- Xie D, Zhang C, Wu X, Wang W, Liu L, Chen L. Design and test of garlic seed placer with seed disturbing tooth assisted air suction. *Agricultural Equipment & Vehicle Engineering*, 2022, **53**(2): 47–57 (in Chinese)
- Cui R, Jian S, Yang J, Wang X, Ma J. Optimization design and test of take garlic spoon. *Journal of Agricultural Mechanization Research*, 2017, **39**(2): 99–102, 107 (in Chinese)
- Hou J, Wang H, Niu Z, Xi R, Li T. Discrete element simulation and experiment of picking and clearing performance of garlic seed-picking device. *Transactions of the Chinese Society of Agricultural Engineering*, 2019, **35**(24): 48–57 (in Chinese)
- Li Y, Zhang Z, Li T, Wu Y, Niu Z, Hou J. Design and experiment of wheel-spoon type garlic precision seed-picking device. *Transactions of the Chinese Society for Agricultural Machinery*, 2020, **51**(3): 61–68 (in Chinese)
- Hou J, Liu Q, Li T, Li Y, Lou W, Geng A. Design and experiment of the garlic seed metering device with double seed-filling chambers. *Transactions of the Chinese Society of Agricultural Engineering*, 2021, **37**(14): 21–32 (in Chinese)
- Guo H, Cao Y, Song W, Zhang J, Wang C, Wang C, Yang F, Zhu L. Design and simulation of a garlic seed metering mechanism. *Agriculture*, 2021, **11**(12): 1239
- Li Y, Wang C, Wang T, Rong L, Zhang J, Cao Y, Wang C, Song W, Zhu L, Guo H. Design and experiment of a type hole wheel garlic seed metering device. *Proceedings of the Institution of Mechanical Engineers. Part C, Journal of Mechanical Engineering Science*, 2024, **238**(5): 1203–1217
- Zhang X, Yi S, Tao G, Zhang D, Chong J. Design and experimental study of spoon-clamping type garlic precision seeding device. *Wireless Communications and Mobile Computing*, 2022, **2022**: 5222651
- Zhang C, Zhang X, Zheng Z, Xie X, Liu L, Chen L. Numerical simulation and test of the disturbance air suction garlic seed metering device. *Machines*, 2022, **10**(12): 1127
- Wang J, Tang H, Zhou W, Yang W, Wang Q. Improved design and experiment on pickup finger precision seed metering device. *Transactions of the Chinese Society for Agricultural*

- Machinery*, 2015, **46**(9): 68–76 (in Chinese)
20. Geng D, Li Y, Meng P, Du R, Meng F. Design and test on telescopic clip finger type of metering device. *Transactions of the Chinese Society for Agricultural Machinery*, 2016, **47**(5): 38–45 (in Chinese)
 21. Zhang X, Cheng J, Shi Z, Wang M, Fu H, Wu H. Simulation and experiment of seed taking performance of swing-clamp type maize precision seed-metering device. *Transactions of the Chinese Society for Agricultural Machinery*, 2023, **54**(4): 38–50 (in Chinese)
 22. Wang Y, Gao Y, Tai W, Wang Y, Lü J, Yang D. Design and test of pickup finger potato precision seed metering device. *Transactions of the Chinese Society for Agricultural Machinery*, 2021, **52**(11): 49–58 (in Chinese)
 23. Wang H, Sun X, Li H, Fu J, Zeng X, Xu Y, Wang Y, Liu H, Lü Z. Design and parameter optimization of a finger clip plate garlic seed-metering device based on EDEM. *Agronomy*, 2022, **12**(7): 1543